



This is a digital copy of a book that was preserved for generations on library shelves before it was carefully scanned by Google as part of a project to make the world's books discoverable online.

It has survived long enough for the copyright to expire and the book to enter the public domain. A public domain book is one that was never subject to copyright or whose legal copyright term has expired. Whether a book is in the public domain may vary country to country. Public domain books are our gateways to the past, representing a wealth of history, culture and knowledge that's often difficult to discover.

Marks, notations and other marginalia present in the original volume will appear in this file - a reminder of this book's long journey from the publisher to a library and finally to you.

### **Usage guidelines**

Google is proud to partner with libraries to digitize public domain materials and make them widely accessible. Public domain books belong to the public and we are merely their custodians. Nevertheless, this work is expensive, so in order to keep providing this resource, we have taken steps to prevent abuse by commercial parties, including placing technical restrictions on automated querying.

We also ask that you:

- + *Make non-commercial use of the files* We designed Google Book Search for use by individuals, and we request that you use these files for personal, non-commercial purposes.
- + *Refrain from automated querying* Do not send automated queries of any sort to Google's system: If you are conducting research on machine translation, optical character recognition or other areas where access to a large amount of text is helpful, please contact us. We encourage the use of public domain materials for these purposes and may be able to help.
- + *Maintain attribution* The Google "watermark" you see on each file is essential for informing people about this project and helping them find additional materials through Google Book Search. Please do not remove it.
- + *Keep it legal* Whatever your use, remember that you are responsible for ensuring that what you are doing is legal. Do not assume that just because we believe a book is in the public domain for users in the United States, that the work is also in the public domain for users in other countries. Whether a book is still in copyright varies from country to country, and we can't offer guidance on whether any specific use of any specific book is allowed. Please do not assume that a book's appearance in Google Book Search means it can be used in any manner anywhere in the world. Copyright infringement liability can be quite severe.

### **About Google Book Search**

Google's mission is to organize the world's information and to make it universally accessible and useful. Google Book Search helps readers discover the world's books while helping authors and publishers reach new audiences. You can search through the full text of this book on the web at <http://books.google.com/>

*given by*  
*Friends*  
*of the*  
*Stanford*  
*Law Library*

CS  
ZAV  
P.  
v.18

*given by*  
*Friends*  
*of the*  
*Stanford*  
*Law Library*

CS  
ZAV  
P.  
v.18

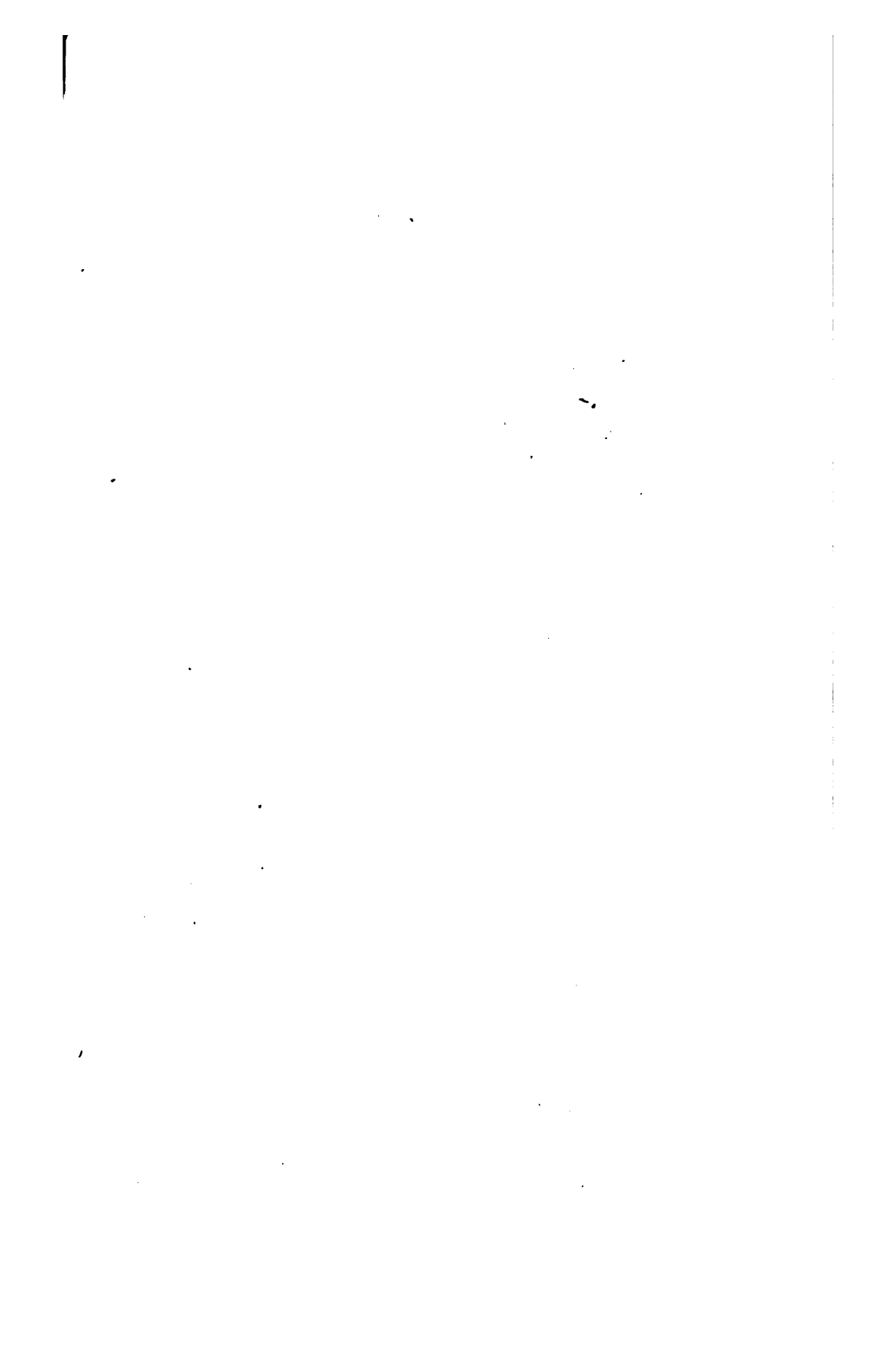

**BRODIX'S AMERICAN AND ENGLISH PATENT CASES.**

VOL. XVIII.

**DECISIONS**

ON THE LAW OF

**PATENTS FOR INVENTIONS**

RENDERED BY

**THE UNITED STATES SUPREME COURT**

FROM THE BEGINNING.

THIS VOLUME FROM

126 U. S. - - - - - 127 U. S.

1888.

1888.

---

EDITED AND ANNOTATED

BY

**WOODBURY LOWERY.**

---

WASHINGTON, D. C.

**THE BRODIX PUBLISHING COMPANY,**

LAW PUBLISHERS.

1891.

Entered, according to the Act of Congress, in the year 1891,  
By THE BRODIX PUBLISHING COMPANY,  
In the Office of the Librarian of Congress, at Washington, D. C.

---

Press of GEO. F. LASHER, 1213-15 Filbert Street, Philadelphia, Pa.



## EXPLANATION OF NOTES.

---

### The Text of the Opinion.

The text of the opinion of the Court is taken wholly from the record, and not from the official reporter. The reason for this is that the record is the original source from which the reporter himself obtains his matter; that it is complete, no cases decided by the Court being omitted therefrom; that on application to the Clerk of the Court for a certified copy of an opinion, it is the copy of the opinion as it appears in the record, and not as printed in the official report that he furnishes.

Prominent among the advantages secured by printing the record, is the fact that the statement of the case, involving all those facts which the Court considers material to the understanding of its opinion is made by the Court itself, strictly in view of its decision, concisely and judicially, whereas the official reporters, Wallace and Otto, have omitted whole pages of the statement as made by the Court, substituting their own, or have so amended and varied the Court's statement as to make it practically a new one. The case of Packing Company Cases, reported in volume 14, p. 49, is a notable example, on consulting which the foot-notes appended will be found to point out the variation of the official reporter from the original record.

It will also be observed that this practice of these reporters has often been the cause of omitting in their reports the introductory part of the opinion as given in the record, supplying it from their own point of view and actually beginning the report of the opinion at an intermediate point of the record.

The text in this work has been prepared from printed certified copies of the record, and has undergone a second comparison while in type before printing, made directly with the original record in the Supreme Court, giving an assurance that no effort has been spared to secure accuracy.

## EXPLANATION OF NOTES.

It has further been compared with the officially published reports and the divergences of the latter from the record, pointed out in foot-notes to each case where they occur, in justification of the course pursued by the editor, and for the convenience of the profession.

### **The Syllabi, or The Head-Notes.**

The head-notes have been prepared with care and considerable elaboration, the editor deeming it more convenient to the profession that he should err on the side of too great minutia in calling their attention even to what may be regarded as *dicta* of the Court. At the end of each head-note will be found, between brackets, the page of the opinion of which it is a digest. The head-notes are numbered consecutively, and at the end of each case there will be found under the corresponding number of the head-note a note of Supreme Court Patent Cases, in chronological order, relative to the subject-matter of the head-note.

### **The Annotations, or Notes at Ending of Case.**

**Notes at ending of case** are of three kinds: Those in the form of notes to the head-notes; those relating to the patent in suit; and those relating to cases in which the particular case reported has been cited.

**Notes to the head-notes.** These consist of Supreme Court Patent Cases, arranged in chronological order, in which the substance of the head-note has been restated, affirmed, or applied, as the case may be; these have been brought down to the latest decisions of the Court, accessible at the date of printing the volume.

**The patent in suit** is next given with its reissues, if any, followed by a chronological list of all reported Federal suits in which the patent has been involved.

**Citations of the particular opinion.** Then follows a list of those cases in which the opinion reported has been cited. This list includes Federal, State, and Canadian Cases, opinions of the Attorney-General, and of the Commissioner of Patents, and the latest text-books, Curtis, 4th Edit., Walker, Merwin, Abbott and Robinson.

All the lists are chronological in arrangement, and in the list of citations the dates are appended.

## EXPLANATION OF NOTES.

v

### **Additional References, etc.**

To facilitate the finding of any case appearing in the notes, not only is the original report given, but also volume and page of Robb, Fisher, Banning and Arden, and others in which it is reprinted.

Both in the opinion and arguments the rule has been followed of adding the *names* to cases cited by page and volume only, these additions to the text being included in brackets.

Blank-lined spaces after each note and a blank page at the end of each case are left for the insertion of additional citations and of general notes.

### **Tables.**

There are added a number of tables and two indexes for ready reference. These are Tables of Cases, Reference Table of Cases, Table of Patents in Suit, of Cases Cited, of Abbreviations, of Names of Justices, of Names of Counsel, an Index Digest, and a Digest of Notes.

Reference is made throughout the work to the volume and page of the English cases already published as part of this series, wherever they occur.

WOODBURY LOWERY.

WASHINGTON, D. C.,  
*April 1, 1890.*

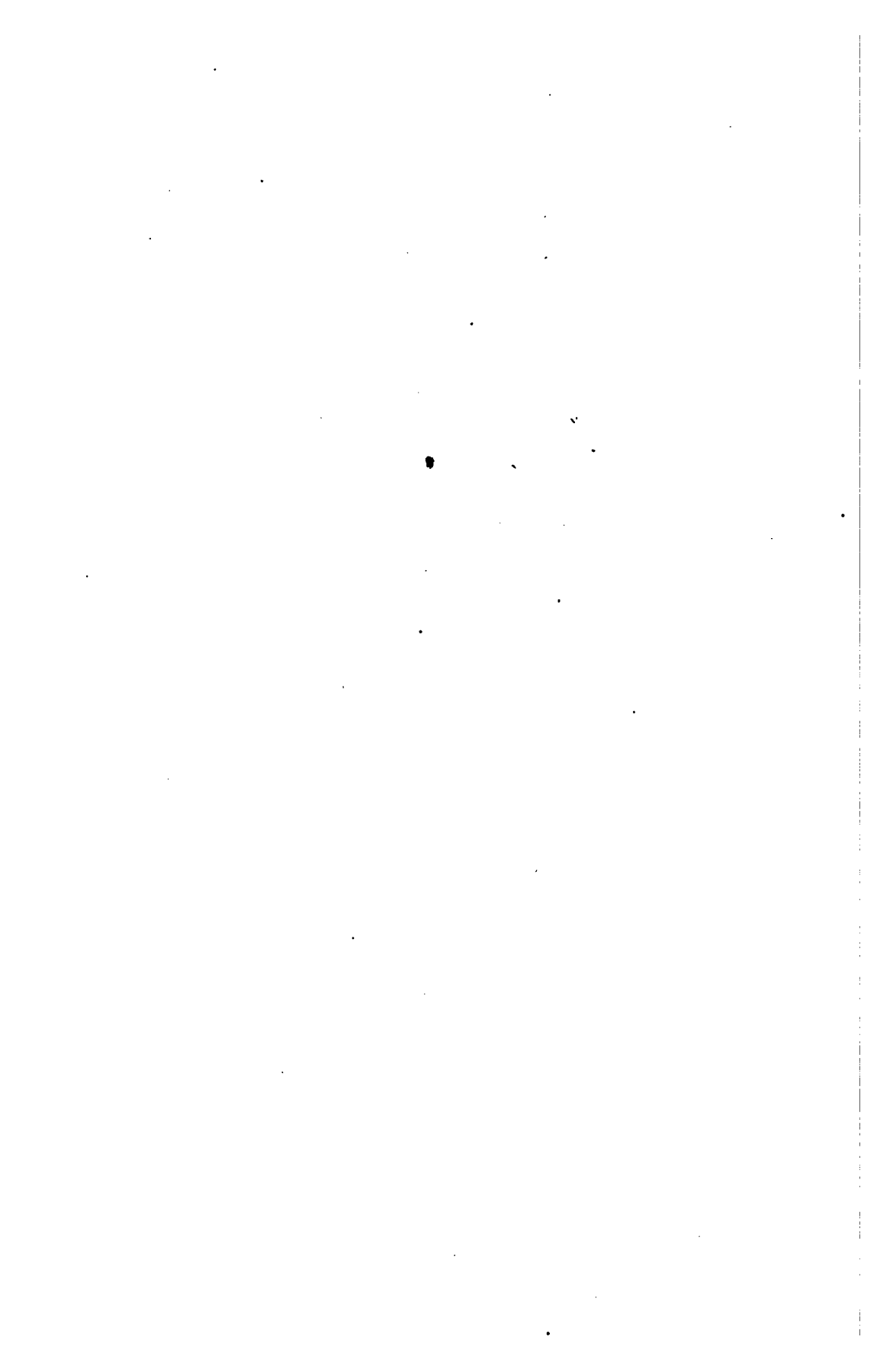

## TABLE OF CONTENTS.

---

	PAGE.
EXPLANATION OF NOTES.....	iii
ALPHABETICAL TABLE OF CASES.....	ix
REFERENCE TABLE OF CASES.....	xi
REFERENCE TABLE OF COMPARATIVE PAGES.....	xii
TABLE OF PATENTS IN SUIT.....	xv
TABLE OF CITATIONS.....	xvi
TABLE OF ABBREVIATIONS.....	xxx
TABLE OF NAMES OF JUSTICES.....	xxxv
TABLE OF NAMES OF COUNSEL.....	xxxvi
CASES REPORTED.....	1-640
INDEX DIGEST.....	641
INDEX TO NOTES.....	651



## ALPHABETICAL TABLE OF CASES

REPORTED IN THIS VOLUME.

	PAGE.
AMERICAN BELL TELEPHONE CO. <i>v.</i> MOLECULAR TELEPHONE CO. See TELEPHONE CASES.....	1
CHILlicoTHE FOUNDRY & MACHINE WORKS CO., JOYCE <i>v.</i>	612
CITY OF DETROIT, FLOWER <i>v.</i> .....	621
CLAY COMMERCIAL TELEPHONE CO. <i>v.</i> AMERICAN BELL TELEPHONE CO. See TELEPHONE CASES.....	1
CORNELL <i>v.</i> WEIDNER. 127 U. S. 261-265. Oct. Term, 1887. 549 [Bk. 32, L. ed. 148; 43 O. G. 985.] <i>Particular reissued patent construed and is void for unwarrantable enlargement.</i>	549
DOLBEAR <i>v.</i> AMERICAN BELL TELEPHONE CO. See TELEPHONE CASES.....	1
FLOWER <i>v.</i> CITY OF DETROIT, ET AL. 127 U. S. 563-572. Oct. Term, 1887..... [Bk. 32, L. ed. 175; 43 O. G. 1348.] Affirming <i>Ibid</i> , 22 Fed. Rep. 292. <i>Particular reissued patent construed. Model as basis for reissue.</i>	621
FORNCROOK <i>v.</i> ROOT. 127 U. S. 176-181. Oct. Term, 1887... 537 [Bk. 32, L. ed. 97; 43 O. G. 984.] Affirming <i>Ibid</i> , 21 Fed. Rep. 328. <i>Particular patent construed. Mechanical equivalent.</i>	537
GOLDEN STATE & MINERS' IRON WORKS, HENDY <i>v.</i> .....	588
HENDY <i>v.</i> GOLDEN STATE & MINERS' IRON WORKS. 127 U. S. 370-376. Oct. Term, 1887..... [Bk. 32, L. ed. 207; 43 O. G. 1117.] Affirming <i>Ibid</i> , 8 Sawy. 468. <i>Particular patent construed. Absence of invention. Aggregation. Infringement and defence.</i>	588
HOLLAND <i>v.</i> SHIPLEY. 127 U. S. 396-398. Oct. Term, 1887.. 605 [Bk. 32, L. ed. 185; 44 O. G. 231.] <i>Particular patent construed. Absence of invention.</i>	605

	PAGE-
JOYCE <i>v.</i> CHILLICOTHE FOUNDRY AND MACHINE WORKS CO. 127 U. S. 557-582. Oct. Term, 1887 .....	612
[Bk. 32, L. ed. 171; 44 O. G. 107.]	
Affirming <i>Ibid</i> , 15 Fed. Rep. 260.	
<i>Particular patent construed, limited and not infringed.</i>	
MOSLER, BAHMANN & CO., MOSLER SAFE & LOCK CO. <i>v.</i> ...	560
MOSLER SAFE AND LOCK CO. <i>v.</i> MOSLER, BAHMANN & CO. 127 U. S. 354-363. Oct. Term, 1887.....	560
[Bk. 32, L. ed. 182; 43 O. G. 1115.]	
Affirming <i>Ibid</i> , 22 Fed. Rep. 901; 31 O. G. 1689.	
<i>Particular patents construed. Article and process of making it. Absence of invention. Aggregation.</i>	
OVERLAND TELEPHONE CO. <i>v.</i> AMERICAN BELL TELEPHONE CO. See TELEPHONE CASES.....	I
PEOPLE'S TELEPHONE CO. <i>v.</i> AMERICAN BELL TELEPHONE CO. See TELEPHONE CASES.....	I
ROOT, FORNCROOK <i>v.</i> .....	537
SHIPLEY, HOLLAND <i>v.</i> .....	605
STARLING, ST. PAUL PLOW WORKS <i>v.</i> .....	598
ST. PAUL PLOW WORKS <i>v.</i> STARLING. 127 U. S. 376-378. Oct. Term, 1887 .....	598
[Bk. 32, L. ed. 251; 43 O. G. 1350.]	
<i>Jurisdiction. Case touching patent rights.</i>	
TELEPHONE CASES:	
AMOS E. DOLBEAR <i>v.</i> AMERICAN BELL TELEPHONE CO.	
MOLECULAR TELEPHONE CO. <i>v.</i> SAME.	
AMERICAN BELL TELEPHONE CO. <i>v.</i> MOLECULAR TELEPHONE CO.	
CLAY COMMERCIAL TELEPHONE CO. <i>v.</i> AMERICAN BELL TELEPHONE CO.	
PEOPLE'S TELEPHONE CO. <i>v.</i> SAME.	
OVERLAND TELEPHONE CO. <i>v.</i> SAME. 126 U. S. 1-584. Oct. Term, 1887.....	I
[Bk. 31, L. ed. 863; 43 O. G. 377.]	
<i>Particular patents construed, sustained and infringed. Process and apparatus. Art. Patentability of process. Principle. Novelty. Evidence of incorporation. Date of prior foreign patent recited in United States patent.</i>	
WEIDNER, CORNELL <i>v.</i> .....	549



REFERENCE TABLE OF CASES.

xi

REFERENCE TABLE OF CASES

DECIDED IN U. S. SUPREME COURT, AND REPORTED IN THIS VOLUME.

Date. Oct. Term.	Brodix's Am. & Eng. Patent Cases. Title of Case.	Vol. XVIII. Page.	Official Reports of U. S. Supreme Court.	Lawyers' Edition of U. S. Supreme Court Reports.	Official Gazette of U. S. Patent Office.
1887.	The Telephone Cases.	I	126 U. S. I.	Bk. 31, L. ed. 863.	43 O. G. 377.
1887.	Forncrook <i>v.</i> Root.	537	127 U. S. 176.	Bk. 32, L. ed. 97.	43 O. G. 984.
1887.	Cornell <i>v.</i> Weidner.	549	127 U. S. 261.	Bk. 32, L. ed. 148.	43 O. G. 985.
1887.	Mosler Safe and Lock Co. <i>v.</i> Mosler, Bah- mann & Co.	560	127 U. S. 354.	Bk. 32, L. ed. 182.	43 O. G. 1115.
1887.	Hendy <i>v.</i> The Golden State & Miners' Iron Works.	588	127 U. S. 370.	Bk. 32, L. ed. 207.	43 O. G. 1117.
1887.	The St. Paul Plow Works <i>v.</i> Starling.	598	127 U. S. 377.	Bk. 32, L. ed. 251.	43 O. G. 1330.
1887.	Holland <i>v.</i> Shipley.	605	127 U. S. 396.	Bk. 32, L. ed. 185.	44 O. G. 231.
1887.	Joyce <i>v.</i> Chillicothe Foundry Machine Works.	612	127 U. S. 557.	Bk. 32, L. ed. 171.	44 O. G. 107.
1887.	Flower <i>v.</i> City of Detroit.	621	127 U. S. 563.	Bk. 32, L. ed. 175.	44 O. G. 1348.

xii REFERENCE TABLE OF COMPARATIVE PAGES.

## REFERENCE TABLE OF COMPARATIVE PAGES

### OF THE OFFICIAL REPORTS AND THIS VOLUME.

The object of comparing the pages in these cases is for convenience of reference showing where the text in the opinion of the Court on each page of the Official Report is found in this edition, or if an attorney wishes to cite the Official Reports while using these volumes, he can readily do so by turning to this table and finding on what page in the official edition any page of the Opinion of the Court in this volume may be found.

In making this comparison, out of justice to ourselves, where we have inserted new material, such as drawings, specifications, arguments of counsel, statements, and parts of the opinion from the records which are not found in the Official edition, we have so indicated.

As an example in the use of this table take the case of *Siemens v. Sellers*, in Vol. 17, which begins in 123 U. S. on page 276—see first column; in Vol. 17, page 284—see third column; the opinion of the Court begins in U. S. on page 276—see second column; in our volume, page 327—see fourth column, and thus through the opinion each page is compared. We have inserted in this volume many drawings and specifications which are not found in the Official Reports, and omissions in the consecutive numbering of the pages can be accounted for in the same manner.

NOTE—Pages containing drawings marked D.  
           "          "          statement " S.

TITLE OF CASES.	OFFICIAL REPORT.		IN THIS VOLUME.	
	Case begins.	Opinion begins.	Case begins.	Opinion begins.
	126 U. S.			
Telephone Cases.	I		I	
" "		531		472
" "		531-532		473
" "		532-533		474
" "		533-534		475
" "		534-535		476
" "		535		477
" "		536		478
" "		536-537		479
" "		537-538		480
" "		538-539		481
" "		539-540		482
" "		540-541		483
" "		541-542		484
" "		542-543		485
" "		543-544		486
" "		544-545		487
" "		545-546		488
" "		546		489
" "		547		490

REFERENCE TABLE OF COMPARATIVE PAGES. xiii

TITLE OF CASE.	OFFICIAL REPORT.		IN THIS VOLUME.	
	Case begins.	Opinion begins.	Case begins.	Opinion begins.
Telephone Cases.	126	<i>U. S.</i>		
" "		547-548		.491
" "		548-549		492
" "		549-550		493
" "		550-551		494
" "		551-552		495
" "		552-553		496
" "		553-554		497
" "		554-555		498
" "		555-556		499
" "		556-557		500
" "		557		501
" "		557-558		502
" "		558-559		503
" "		559-560		504
" "		560-561		505
" "		561-562		506
" "		562-563		507
" "		563-564		508
" "		564-565		509
" "		565-566		510
" "		566-567		511
" "		567		512
" "		567-568		513
" "		568-569		514
" "		569-570		515
" "		570-571		516
" "		571-572		517
" "		572-573		518
" "		573-574		519
" "		574-575		520
" "		575-576		521
" "		576-577		522
<i>Forncrook v. Root.</i>	127	<i>U. S.</i>		
" "	176		537	
" "		177		540
" "				541 D
" "				542 D
" "		177-178		543
" "		178-179		544
" "		179-180		545
" "		180-181		546
<i>Cornell v. Weidner.</i>	127	<i>U. S.</i>		
" "	261		549	
" "		261-262		552
" "				553 D
" "				554 D
" "		262-263		555
" "		263-264		556
" "		264-265		557

xiv REFERENCE TABLE OF COMPARATIVE PAGES.

TITLE OF CASE.	OFFICIAL REPORT.		IN THIS VOLUME.	
	Case begins.	Opinion begins.	Case begins.	Opinion begins.
Mosler Safe and Lock Co. v. Mosler, etc.	127 U. S. 354			
“ “ “ “		355-356	560	577
“ “ “ “		356-357		578
“ “ “ “		357-358		579
“ “ “ “		358-359		580
“ “ “ “		359-360		581
“ “ “ “		360-361		582
“ “ “ “		361-362		583
“ “ “ “		362-363		584
Hendy v. Golden State, etc.	127 U. S. 370		588	
“ “ “ “		370-371		590
“ “ “ “		371-372		591
“ “ “ “		372-374		592
“ “ “ “		374-375		593
“ “ “ “		375-376		594
St. Paul Plow W'ks v. Starling	127 U. S. 376		598	
“ “ “ “		376-377		600
“ “ “ “		377-378		601
“ “ “ “		378		602
Holland v. Shipley.	127 U. S. 397		605	
“ “ “ “		397-398		609
“ “ “ “		398		610
Joyce v. Chillicothe Foundry.	127 U. S. 557		612	
“ “ “ “		558		613
“ “ “ “		558-560		614
“ “ “ “		(559) D		615 D
“ “ “ “		(559) D		616 D
“ “ “ “		560-561		617
“ “ “ “		561-562		618
“ “ “ “		562		619
Flower v. City of Detroit.	127 U. S. 563		621	
“ “ “ “		563-564		625
“ “ “ “		564-565		626
“ “ “ “		(570) D		627 D
“ “ “ “		(570) D		628 D
“ “ “ “		(570) D		629 D
“ “ “ “		(570) D		630 D
“ “ “ “		565-566		631
“ “ “ “		566-567		632
“ “ “ “		567-568		633
“ “ “ “		568		634
“ “ “ “		569		635
“ “ “ “		570-571		636
“ “ “ “		571-572		637
“ “ “ “		572		638

TABLE OF PATENTS IN SUIT.

17

TABLE OF PATENTS IN SUIT

IN CASES REPORTED IN THIS VOLUME.

Number of Patent.	Patentee.	Date of Patent.	Subject of Invention.	Inserted in this Volume.	Title of Case in this Volume.	Page.
No. 174,465	Bell, A. G.	Mch. 7, 1876	Impr'ments in Telegraphy.	Spec. & Drgs.	Telephone Cases.	1
No. 186,787	Bell, A. G.	Jan. 30, 1877	Impr'ments in Telegraphy.		Telephone Cases.	537
No. 243,574	Fornbrook, J., Jr.	June 28, 1881	Sectional Honey Frames.	Drq.	Fornbrook v. Root.	549
No. 118,617	Lacy & Cornell.	Aug. 29, 1871	Metallic Bushings for the Bungings of Casks.	Drq.	Cornell v. Weidner.	
No. 273,585	Mosler, M.	June 17, 1879	Reissue No. 8,759.	Spec. & Drgs.	Mosler Safe and Lock Co. v. Mosler, Bahmann & Co.	560
No. 281,640	Mosler, M.	Mch. 6, 1883	Fire-proof Safes.		Mosler Safe and Lock Co. v. Mosler, Bahmann & Co.	
No. 283,136	Mosler, M.	July 17, 1883	Fire-proof Safes.		Mosler Safe and Lock Co. v. Mosler, Bahmann & Co.	
No. 140,250	Cusenbary & Mars.	Aug. 14, 1883	Fire-proof Safes.	Drq.	Mosler Safe and Lock Co. v. Mosler, Bahmann & Co.	
No. 154,293	Starling, Wm.	June 24, 1873	Ore Stamp Feeders.		Hendy v. The Golden State & Miners' Iron Works.	588
No. 292,313	Holland, J.	Aug. 18, 1874	Sulky Plow.	Spec. & Drgs.	St. Paul Plow Wks v. Starling Holland v. Shipley Tyrrell Mfg. Co.	598
No. 154,989	Joyce, J. O.	Jan. 22, 1884	Lead Holders for Pencils.	Spec. & Drgs.	Joyce v. Chillicothe Foundry and Machine Works.	605
No. 75,344	Bailey, T. R., Jr.	Sept. 15, 1874	Lifting-Jack.	Drq.	Flower v. City of Detroit.	612
		Mch. 10, 1886	Hydrants.		Flower v. City of Detroit.	621
		Mch. 14, 1876	Reissue No. 6,990.		Flower v. City of Detroit.	

## TABLE OF CITATIONS

IN THE CASES REPORTED IN THIS VOLUME.

NOTE.—Cases cited in the Statement marked S.

“	“	“	Argument	“	A.
“	“	“	Opinion	“	Opin.
“	“	“	Dissenting Opinion	marked Dis.	Opin.

Citation.	Where reported.	Page, cited in this Vol.
Adams <i>v.</i> Edwards.....	1 Fish. Pat. Cas. 1.....	417. A.
Agawam Woolen Co. <i>v.</i> Jordan .....	7 Wall, 602 [8 Am. & Eng. 24].....	348, 538. A.
Albright <i>v.</i> Celluloid Har- ness Trimming Co.....	12 Off. Gaz. 228.....	550. A.
Albright <i>v.</i> Teas .....	106 U. S. 613 [14 Am. & Eng. 266].....	599. A.
Alden <i>v.</i> Dewey.....	1 Story, 336.....	538. A.
Allen <i>v.</i> Blunt .....	3 Story, 742.....	551. A.
American Bell Tel. Co. <i>v.</i> Dolbear .....	17 Fed. Rep. 604, 605.....	622. A.
Ames <i>v.</i> Howard.....	1 Sumn. 482, 485.....	358. A.
Andrews <i>v.</i> Hyde .....	3 Cliff. 516, 522.....	622. A.
Atlantic Works <i>v.</i> Brady.....	107 U. S. 192 [14 Am. & Eng. 380].....	415, 417, 538, 623. A.
Atlantic Works <i>v.</i> Brady.....	107 U. S. 192 [14 Am. & Eng. 380].....	512, 593. Opin.
Aultman <i>v.</i> Holley.....	6 Fish. Pat. Cas. 534; 11 Blatch. 317.....	416. A.
Ball <i>v.</i> Langles.....	102 U. S. 130 [12 Am. & Eng. 508].....	621. A.
Baltimore Car Wheel Co. <i>v.</i> North Balto. Pass- enger R. Co.....	21 Fed. Rep. 50.....	600. A.
Bantz <i>v.</i> Elsas .....	6 Off. Gaz. 118.....	551. A.
Bantz <i>v.</i> Frantz.....	105 U. S. 160 [13 Am. & Eng. 542].....	622. A.

TABLE OF CITATIONS.

xvii

Citation.	Where reported.	Page, cited in this Vol
Bartlett v. Holbrook.....	I Gray, 114.....	599. A.
Barrett v. Hall.....	I Mason, 447; I Robb Pat. Cas. 234.....	590. A.
Bates v. Coe.....	98 U. S. 31 [12 Am. & Eng. 150].....	576, 608, 612. A.
Battin v. Taggart.....	17 How. 74 [6 Am. & Eng. 243].....	551. A.
Beams, <i>Eq</i> .....	10.....	549. A.
Beams, <i>Eq</i> .....	48.....	550. A.
Becker v. Hastings.....	22 Fed. Rep. 827.....	551. A.
Bell v. Gray.....	15 Off. Gaz. 778.....	357. A.
Bell v. McCullough.....	I Fish. Pat. Cas. 380.....	600. A.
Bennett v. Fowler.....	8 Wall. 445 [8 Am. & Eng. 124].....	551. A.
Bischoff v. Wethered.....	9 Wall. 812 [8 Am. & Eng. 213].....	358. A.
Blake v. Robertson.....	94 U. S. 728 [11 Am. & Eng. 266].....	358. A.
Blake v. San Francisco.....	113 U. S. 679 [15 Am. & Eng. 535].....	358. A.
Blanchard v. Putnam.....	8 Wall. 420 [8 Am. & Eng. 107].....	608. A.
Blanchard v. Sprague.....	3 Sumn. 535, 539.....	358. A.
Blanchard v. Sprague.....	I Cliff. 288.....	599, 600. A.
Blandy v. Griffith.....	3 Fish. Pat. Cas. 616.....	550. A.
Bloomer v. Gilpin.....	4 Fish. Pat. Cas. 54.....	600. A.
Boogher v. N. Y. L. Ins. Co.....	103 U. S. 90.....	599. A.
Bostock v. Goodrich.....	25 Fed. Rep. 819.....	600. A.
Boulton v. Bull.....	I Carpmael Pat. Cas. 137 [1 Am. & Eng. 59].....	415. A.
Brodie v. Ophir Silver Mining Co.....	4 Fish. Pat. Cas. 137.....	417. A.
Brown v. Guild.....	23 Wall. 181 [10 Am. & Eng. 1].....	416, 551. A.
Brown v. Lapham.....	27 Fed. Rep. 77.....	600. A.
Brown v. Shannon.....	20 How. 55 [6 Am. & Eng. 354].....	599. A.
Brown v. Shannon.....	20 How. 55 [6 Am. & Eng. 354].....	602. Opin.
Brooks v. Stolley.....	3 McLéan, 523.....	599, 600. A.
Burr v. Duryee.....	I Wall. 531 [7 Am. & Eng. 224].....	344, 357. A.
Burr v. Duryee.....	2 Fish. Pat. Cas. 285.....	599, 600. A.
Burr v. Gregory.....	2 Paine, 426.....	599. A.
Burrall v. Jewett.....	2 Paige, 143.....	348. A.

## TABLE OF CITATIONS.

Citation.	Where reported.	Page, cited in this Vol.
<i>Bussey v. Excelsior Mfg.</i>		
Co . . . . .	110 U. S. 131 [15 Am. & Eng. 77] . . . . .	590. A.
<i>Bussey v. Excelsior Mfg.</i>		
Co . . . . .	110 U. S. 131 [15 Am. & Eng. 77] . . . . .	594. Opin.
<i>Byam v. Bullard</i> . . . . .	1 Curt. 100 . . . . .	608. A.
<i>Cahoon v. Ring</i> . . . . .	1 Fish. Pat. Cas. 397; 1 Cliff. 592 . . . . .	416. A.
<i>Cantrell v. Wallick</i> . . . . .		539. A.
<i>Cantrell v. Wallick</i> . . . . .	117 U. S. 695 [16 Am. & Eng. 322] . . . . .	538. A.
<i>Carpenter v. Providence</i>		
Wash. Ins. Co . . . . .	4 Howard. 185, 218 . . . . .	622. A.
<i>Carver v. Braintree Mfg.</i>		
Co . . . . .	2 Story, 439 . . . . .	551. A.
<i>Carver v. Braintree Mfg.</i>		
Co . . . . .	2 Story, 439 . . . . .	550. A.
<i>Case v. Brown</i> . . . . .	2 Wall. 320 [7 Am. & Eng. 360] . . . . .	620. A.
<i>Case v. Brown</i> . . . . .	2 Wall. 320 [7 Am. & Eng. 360] . . . . .	621. A.
<i>Cheney v. Gleason</i> . . . . .	125 Mass. 166 . . . . .	417. A.
<i>Chicago Fruit House Co.</i>		
<i>v. Busch</i> . . . . .	2 Biss. 472 . . . . .	550, 551. A.
<i>Chicago &amp; N. W. R. Co.</i>		
<i>v. Sayles</i> . . . . .	97 U. S. 554 [12 Am. & Eng. 121] . . . . .	623. A.
<i>Clark v. Hancock</i> . . . . .	94 U. S. 433 . . . . .	599. A.
<i>Clark Pomace Holder Co.</i>		
<i>v. Ferguson</i> . . . . .	119 U. S. 335 [16 Am. & Eng. 441] . . . . .	593. Opin.
<i>Clements v. Odorless Ex-</i>		
<i>cavating Apparatus Co.</i>	109 U. S. 641 [15 Am. & Eng. 44] . . . . .	622. A.
<i>Clifton v. U. S.</i> . . . . .	4 How. 242 . . . . .	417, 418. A.
<i>Clough v. Barker</i> . . . . .	106 U. S. 166 [14 Am. & Eng. 211] . . . . .	358, 612, 622. A.
<i>Coburn v. Schroeder</i> . . . . .	22 Off. Gaz. 1538 . . . . .	551. A.
<i>Cochrane v. Deener</i> . . . . .	94 U. S. 787 [11 Am. & Eng. 288] . . . . .	358. A.
<i>Cochrane v. Deener</i> . . . . .	94 U. S. 780 [11 Am. & Eng. 288] . . . . .	475. Opin.
<i>Coffin v. Ogden</i> . . . . .	18 Wall. 120 [9 Am. & Eng. 125] . . . . .	415, 469, 538, 608. A.



TABLE OF CITATIONS.

xix

Citation.	Where reported.	Page, cited in this Vol.
Colt <i>v.</i> Massachusetts Arms Co. ....	1 Fish. Pat. Cas. 116 .....	416. A.
Commonwealth <i>v.</i> Webster... ..	5 Cush. 316 .....	417. A.
Comstock <i>v.</i> Saudusky Seat Co ....	3 Ban. & Ard. 188 .....	417. A.
Consolidated Fruit Jar Co. <i>v.</i> Wright .....	94 U. S. 92 [11 Am. & Eng. 46] .....	539. A.
Consolidated S. Valve Co. <i>v.</i> Crosby Steam Gauge & Valve Co. ....	113 U. S. 157 [15 Am. & Eng. 460] .....	358, 576. A.
Coon <i>v.</i> Wilson .....	113 U. S. 277 [15 Am. & Eng. 504] .....	552, 621. A.
Corning <i>v.</i> Burden .....	15 How. 252 [6 Am. & Eng. 69]	340, 358, 475. A.
Corning <i>v.</i> Troy I. and N. Factory .....	15 How. 451 [6 Am. & Eng. 144] .....	357. A.
Cox <i>v.</i> Griggs .....	1 Biss. 362 .....	589. A.
Crandal <i>v.</i> Parker Carriage Goods Co. ....	20 Fed. Rep. 851 .....	551. A.
Crawford <i>v.</i> Heysinger ..	123 U. S. 589 [17 Am. & Eng. 367] .....	594. Opin.
Crouch <i>v.</i> Speer .....	1 Ban. & Ard. 145, 6 Off. Gaz. 187 .....	416, 576. A.
Curt. Patents .....	§ 269 .....	621. A.
Curt. Patents .....	§ 496 .....	599. A.
Curt. Patents .....	§ 285 .....	621. A.
Curt. Patents .....	4th ed. § 300 .....	608. A.
Dale Tile Mfg. Co. <i>v.</i> Hyatt .....	125 U. S. 46 [17 Am. & Eng. 508] .....	602. Opin.
Dane <i>v.</i> Chicago Mfg. Co. 6 Fish. Pat. Cas. 130, 133 ..		623. A.
Davoll <i>v.</i> Brown .....	1 Wood & M. 53, 57 .....	358. A.
Daniel Ch .....	Vol. 1, p. 603, note 4 .....	549. A.
Day <i>v.</i> Hartshorn .....	3 Fish. Pat. Cas. 32 .....	600. A.
Dixon <i>v.</i> Moyer .....	1 Robb Pat. Cas. 324 .....	417. A.
Dorsey Harvester Rake Co. <i>v.</i> Marsh .....	6 Fish. Pat. Cas. 398 .....	550, 551. A.
Doubleday <i>v.</i> Beatty ....	11 Fed. Rep. 729 .....	417. A.
Downton <i>v.</i> Yeager Milling Co. ....	108 U. S. 466 [14 Am. & Eng. 513] .....	538, 539. A.
Downton <i>v.</i> Yeager Milling Co. ....	1 McCrary, 30, 31 .....	339. A.

## TABLE OF CITATIONS.

Citation.	Where reported.	Page, cited in this Vol.
Draper <i>v.</i> Potomska Mills Corp .....	3 Ban. & Ard. 214.....	417. A.
Driven Well Cases .....	122 U. S. 40, 71 [17 Am. & Eng. 98] .....	551. A.
Dryfoos <i>v.</i> Wiess.....	124 U. S. 32 [17 Am. & Eng. 425].....	546. Opin.
Dunbar <i>v.</i> Myers.....	94 U. S. 187 [11 Am. & Eng. 59].....	593. Opin.
Eachus <i>v.</i> Broomall.....	115 U. S. 429, 438 [15 Am. & Eng. 176].....	550, 621. A.
Eagleton Mfg. Co. <i>v.</i> West B. & C. Mfg. Co .....	18 Blatch. 218, 220, 222....	623. A.
Egbert <i>v.</i> Lippmann.....	104 U. S. 333 [13 Am. & Eng. 273].....	539. A.
Elgin <i>v.</i> Marshall .....	106 U. S. 578.....	599. A.
Ely <i>v.</i> Monson & B. Mfg. Co.....	4 Fish. Pat. Cas. 79.....	415. A.
Evans <i>v.</i> Eaton.....	7 Wheat. 356 [4 Am. & Eng. 105].....	357. A.
Evanston <i>v.</i> Gunn.....	99 U. S. 660.....	620. A.
Fay <i>v.</i> Cordesman .....	109 U. S. 408 [15 Am. & Eng. 1].....	546, 594. Opin.
Furbush <i>v.</i> Cook.....	2 Fish. Pat. Cas. 668.....	620. A.
Gage <i>v.</i> Herring .....	107 U. S. 640 [14 Am. & Eng. 454].....	54. Opin.
Gage <i>v.</i> Herring .....	107 U. S. 640 [14 Am. & Eng. 454].....	539, 550, 622. A.
Galt <i>v.</i> Galloway.....	4 Pet. 343.....	620. A.
Garneau <i>v.</i> Dozier .....	102 U. S. 230 [12 Am. & Eng. 545].....	550. A.
Gay <i>v.</i> Parpart.....	106 U. S. 679 .....	417. A.
Gayler <i>v.</i> Wilder.....	10 How. 477 [5 Am. & Eng. 188] .....	469. A.
Giant Powder Co. <i>v.</i> California Powder Works ..	98 U. S. 126 [12 Am. & Eng. 201].....	521, 621. A.
Giant Powder Co. <i>v.</i> Safety Nitro Powder Co .....	19 Fed. Rep. 513 .....	549, 550. A.
Gibson <i>v.</i> Harris .....	1 Blatch. 169 .....	621. A.
Gill <i>v.</i> Wells.....	22 Wall. 1 [9 Am. & Eng. 471] .....	539. A.
Gloucester Isinglass and Glue Co. <i>v.</i> Brooks.....	19 Fed. Rep. 426 .....	417. A.
Gong Bell Mfg. Co. <i>v.</i> Clark .....	13 Off. Gaz. 275.....	550, 551. A.

TABLE OF CITATIONS.

xxi

Citation.	Where reported.	Page, cited in this Vol.
Goodyear <i>v.</i> Congress Rubber Co	3 Blatch. 449	600. A.
Goodyear <i>v.</i> Day	1 Blatch. 565	599. A.
Goodyear <i>v.</i> Day	2 Wall. Jr. 283	416. A.
Goodyear <i>v.</i> Union India Rubber Co	4 Blatch. 63	599. A.
Goosling <i>v.</i> Roberts	106 U. S. 39 [14 Am. & Eng. 143]	621. A.
Gottfried <i>v.</i> Phillip Best Brewing Co	5 Ban. & Ard. 4	416. A.
Grant <i>v.</i> Grant	34 Beav. 623, 727	622. A.
Grant <i>v.</i> Raymond	6 Pet. 218 [4 Am. & Eng. 245]	358. A.
Greenl. Ev.	Vol. I., § 496	620. A.
Greenwood <i>v.</i> Bracher	1 Fed. Rep. 856	576. A.
Guidet <i>v.</i> Barber	5 Off. Gaz. 149	551. A.
Hailes <i>v.</i> Albany Stove Co	123 U. S. 586 [17 Am. & Eng. 336]	577. A.
Hailes <i>v.</i> Van Wormer	20 Wall. 368 [9 Am. & Eng. 340]	539, 577. A.
Hailes <i>v.</i> Van Wormer	20 Wall. 353 [9 Am. & Eng. 340]	540, 583, 594. Opin.
Hall <i>v.</i> MacNeale	107 U. S. 90 [14 Am & Eng. 291]	539. A.
Hamilton <i>v.</i> Ives	92 U. S. 426 [10 Am. & Eng. 405]; 6 Fish. Pat. Cas. 244	329. A.
Hanford <i>v.</i> Wescott	16 Off. Gaz. 1181	576. A.
Hartell <i>v.</i> Tilghman	99 U. S. 547 [12 Am. & Eng. 250]	599. A.
Haworth <i>v.</i> Hardcastle	Web. Pat. Cas. 484 [2 Am. & Eng. 19]	358. A.
Hawes <i>v.</i> Antidel	2 Ban. & Ard. 10	416, 623. A.
Hayden <i>v.</i> Suffolk Mfg. Co	4 Fish. Pat. Cas. 94	416. A.
Heald <i>v.</i> Rice	104 U. S. 737 [13 Am. & Eng. 460]	577, 621. A.
Hicks <i>v.</i> Otto	19 Fed. Rep. 749	576. A.
Hill <i>v.</i> Whitcomb	1 Holmes, 317	599. A.
Hoe <i>v.</i> Cottrell	17 Blatch. 546	576. A.
Hoffheins <i>v.</i> Brandt	3 Fish. Pat. Cas. 218	589. A.
Hoffheins <i>v.</i> Russell	107 U. S. 132 [14 Am. & Eng. 312]	621. A.
Hogg <i>v.</i> Emerson	11 How. 587 [5 Am. & Eng. 279]	620. A.
Hogg <i>v.</i> Emerson	6 How. 473 [5 Am. & Eng. 1]	620. A.
Holliday <i>v.</i> Pickhardt	12 Fed. Rep. 147; 22 Off. Gaz. 420	576. A.

Citation.	Where reported.	Page, cited in this Vol.
<b>Hopkins &amp; D. Mfg. Co. v.</b>		
Corbin .....	103 U. S. 786 [13 Am. & Eng. 147] .....	621. A.
<b>Hoskin v. Fisher</b> .....		
	125 U. S. 217 [17 Am. & Eng. 589] .....	631. Opin.
<b>Househill Co. v. Neilson.</b>		
	Web. Pat. Cas. 683, 715....	357. A.
<b>Howard v. Christy</b> .....		
	2 Ban. & Ard. 457, 458.....	623. A.
<b>Howe v. Morton</b> .....		
	1 Fish. Pat. Cas. 586.....	621. A.
<b>Howe v. Underwood</b> ....		
	1 Fish. Pat. Cas. 162.....	415, 590. A.
<b>Hyndman v. Roots</b> ....		
	97 U. S. 232 [12 Am. & Eng. 29] .....	613. A.
<b>Imhaeuser v. Buerk</b> ....		
	101 U. S. 656 [12 Am. & Eng. 443] .....	539, 608. A.
<b>Ives v. Sargent</b> .....		
	119 U. S. 652, 662, 663 [16 Am. & Eng. 512].....	622. A.
<b>Jacobs v. Baker</b> .....		
	7 Wall. 295.....	357. A.
<b>James v. Campbell</b> .....		
	104 U. S. 377 [13 Am. & Eng. 341].....	358, 551, 621. A.
<b>Johnson v. Flushing &amp; N. S. R. R. Co.</b> .....		
	105 U. S. 539 [14 Am. & Eng. 19].....	552, 621. A.
<b>Johnson v. Root</b> .....		
	2 Fish. Pat. Cas. 292.....	416. A.
<b>Judson v. Bradford</b> .....		
	3 Ban. & Ard. 539.....	415, 417. A.
<b>Kearney v. Case</b> .....		
	12 Wall. 275.....	599. A.
<b>Kearney v. Lehigh Val- ley R. R. Co.</b> .....		
	32 Fed. Rep. 320.....	589. A.
<b>Kendall v. Winsor</b> .....		
	21 How. 322 [7 Am. & Eng. 1].....	415. A.
<b>Kerosene Lamp Heater</b>		
<b>Co. v. Littell</b> .....		
	13 Off. Gaz. 1009.....	550. A.
<b>Kinsman v. Parkhurst</b> ..		
	18 How. 289 [6 Am. & Eng. 273].....	599. A.
<b>Kelleher v. Darling</b> .....		
	4 Cliff. 424.....	415. A.
<b>Kneass v. Schuylkill Bank</b> .....		
	4 Wash. 9.....	589. A.
<b>Kneeland v. Sheriff</b> .....		
	2 Fed. Rep. 901.....	417. A.
<b>La Baw v. Hawkins</b> .....		
	1 Ban. & Ard. 428; 6 Off. Gaz. 725.....	416, 551. A.
<b>Lee v. Blandy</b> .....		
	2 Fish. Pat. Cas. 93.....	539. A.
<b>Lelmbeuter v. Holthaus</b> ..		
	105 U. S. 94.....	538. A.
<b>Le Roy v. Tatham</b> .....		
	14 How. 156 [5 Am. & Eng. 313].....	357. A.
<b>Littlefield v. Perry</b> .....		
	21 Wall. 205 [9 Am. & Eng. 446].....	600. A.
<b>Lockwood v. Cutter Power Co.</b> .....		
	18 Fed. Rep. 653.....	417. A.

TABLE OF CITATIONS.

xxiii

Citation.	Where reported.	Page, cited in this Vol.
Lowell <i>v.</i> Lewis.....	1 Mason, 186.....	589. A.
McClurg <i>v.</i> Kingsland....	1 How. 202 [4 Am. & Eng. 382].....	357. A.
McComb <i>v.</i> Ernest.....	1 Woods, 195.....	576, 589. A.
McCormick <i>v.</i> Seymour..	2 Blatch. 240.....	538, 539, 621. A.
McCormick <i>v.</i> Seymour..	3 Blatch. 213.....	416. A.
McCormick <i>v.</i> Talcott....	20 How. 402 [6 Am. & Eng. 410].....	358. A.
McDonough <i>v.</i> O'Niel....	113 Mass. 92.....	417. A.
McMurray <i>v.</i> Mallory....	111 U. S. 97, 103 [15 Am. & Eng. 171].....	621. A.
Magic Ruffle Co. <i>v.</i> Doug- las .....	2 Fish. Pat. Cas. 330.....	416. A.
Magic Ruffle Co. <i>v.</i> Elm City Co .....	13 Blatch. 157.....	600. A.
Mahn <i>v.</i> Harwood.....	112 U. S. 354 [15 Am. & Eng. 322].....	594. Opin.
Mahn <i>v.</i> Harwood.....	112 U. S. 354 [15 Am. & Eng. 322].....	552. A.
Many <i>v.</i> Jagger.....	1 Blatch. 372.....	589. A.
Marsh <i>v.</i> Seymour.....	97 U. S. 348 [12 Am. & Eng. 53].....	551. A.
Marston <i>v.</i> Swett.....	66 N. Y. 206; 82 N. Y. 526..	599. A.
Matthews <i>v.</i> Boston Ma- chine Co.....	105 U. S. 54 [13 Am. & Eng. 501].....	622. A.
Matthews <i>v.</i> Boston Mach. Co. ....	105 U. S. 54 [13 Am. & Eng. 501].....	632. Opin.
Matthews <i>v.</i> Ironclad Mfg. Co.....	124 U. S. 347, 351.....	622. A.
Meserole <i>v.</i> Union Paper Collar Co.....	6 Blatch. 356.....	599. A.
Miller <i>v.</i> Bridgeport Brass Co. ....	104 U. S. 350 [13 Am. & Eng. 303].....	551, 552, 622. A.
Miller <i>v.</i> Foree.....	116 U. S. 22 [16 Am. & Eng. 193].....	358. A.
Mitchell <i>v.</i> Tilghman....	19 Wall. 287 [9 Am. & Eng. 174].....	358, 623. A.
Moffitt <i>v.</i> Rogers.....	106 U. S. 423 [14 Am. & Eng. 244].....	621. A.
Moody <i>v.</i> Tabor.....	1 Ban. & Ard. Pat. Cas. 41..	600. A.
Motte <i>v.</i> Bennett.....	2 Fish. Pat. Cas. 642.....	416. A.
Morey <i>v.</i> Lockwood.....	8 Wall. 230 [8 Am. & Eng. 78].....	550. A.

## TABLE OF CITATIONS.

Citation.	Where reported.	Page, cited in this Vol.
Morton <i>v.</i> New York Eye Infirmary.....	5 Blatch. 121.....	348. A.
Mowry <i>v.</i> Whitney.....	14 Wall. 439 [8 Am. & Eng. 506] .....	621. A.
National Car-brake Shoe Co. <i>v.</i> Terre Haute Car & Mfg. Co.....	19 Fed. Rep. 514.....	417. A.
Neilson <i>v.</i> Harford.....	Web. Pat. Cas. 341. ....	358. A.
Neilson <i>v.</i> Harford.....	1 Web. Pat. Cas. 317.....	540. Opin.
New Process Fermentation Co. <i>v.</i> Maus.....	122 U. S. 413 [17 Am. & Eng. 157].....	475. Opin.
Newton <i>v.</i> Furst & B. Mfg. Co.....	119 U. S. 373 [16 Am. & Eng. 450].....	622. A.
Odell <i>v.</i> Stout.....	22 Fed. Rep. 159.....	551. A.
O'Reilly <i>v.</i> Morse.....	15 How. 62 [5 Am. & Eng 483].....	284, 344, 357, 417, 550, 551. A.
O'Reilly <i>v.</i> Morse.....	15 How. 62 [5 Am. & Eng. 483] .....	476, 517. Opin.
Parker & Whipple Co. <i>v.</i> Yale Clock Co.....	123 U. S. 87 [17 Am. & Eng. 194].....	621. A.
Parker & Whipple Co. <i>v.</i> Yale Clock Co.....	123 U. S. 87 [17 Am. & Eng. 194] .....	630. Opin.
Parham <i>v.</i> American But- tonhole, O. & S. M. Co.....	4 Fish Pat. Cas. 468.....	415, 416, 417. A.
Parker <i>v.</i> Haworth.....	4 McLean, 372.....	358. A.
Parker <i>v.</i> Hulme.....	1 Fish. Pat. Cas. 44.....	357. A.
Patterson <i>v.</i> Duff.....	20 Fed. Rep. 641.....	417. A.
Pennsylvania R. Co. <i>v.</i> Lo- comotive E. S. Truck Co.....	110 U. S. 490 [15 Am. & Eng. 148] .....	358, 590. A.
Peterson <i>v.</i> Simpkins....	25 Fed. Rep. 486.....	608. A.
Peck S. & W. Co. <i>v.</i> Lind- say.....	2 Fed. Rep. 688.....	576. A.
Phillips <i>v.</i> Detroit.....	111 U. S. 604 [15 Am. & Eng. 269].....	538. A.
Pickering <i>v.</i> McCullough.....	104 U. S. 310 [13 Am. & Eng. 238] .....	539. A.
Pickering <i>v.</i> McCullough.....	104 U. S. 310 [13 Am. & Eng. 238] .....	540, 583, 594. Opin.
Pickering <i>v.</i> McCullough.....	104 U. S. 319 [13 Am. & Eng. 238].....	329, 577. A.
Pitts <i>v.</i> Hall.....	2 Blatch. 234. ....	538, 539, 550. A.

TABLE OF CITATIONS.

XXV

Citation.	Where reported.	Page, cited in this Vol.
• Poppenhusen <i>v.</i> Falke...	5 Blatch. 49; 2 Fish. Pat. Cas.	
	213.....	538, 551. A.
Providence Rubber Co. <i>v.</i>		
Goodyear. ....	9 Wall. 788 [8 Am. & Eng.	
	150].....	551, 620. A.
Pulte <i>v.</i> Derby.....	5 McLean, 328.....	599, 600. A.
Putnam <i>v.</i> Hollender....	19 Blatch. 48; 6 Fed. Rep. 882.	416. A.
Ransom <i>v.</i> Mayor of N. Y. I	Fish. Pat. Cas. 252.....	416, 590. A.
Reckendorfer <i>v.</i> Faber....	92 U. S. 357 [10 Am. & Eng.	
	373].....	539, 577. A.
Reckendorfer <i>v.</i> Faber....	92 U. S. 347 [10 Am. & Eng.	
	373].....	540, 583, 594. Opin.
Reed <i>v.</i> Cutter.....	1 Story, 590.....	417. A.
Reeves <i>v.</i> Keystone Bridge		
Co.....	1 Off. Gaz. 466.....	417. A.
Rhode Island <i>v.</i> Massa-		
chusetts.....	14 Pet. 261.....	549. A.
Richardson <i>v.</i> Noyes.....	2 Ban. & Ard. 398.....	539. A.
Roemer <i>v.</i> Headley.....	19 Fed. Rep. 205.....	417. A.
Roberts <i>v.</i> Dickey.....	4 Fish. Pat. Cas. 532.....	416. A.
Roberts <i>v.</i> Schreiber.....	18 Off. Gaz. 125.....	416. A.
Roberts <i>v.</i> Reed Torpedo		
Co.....	3 Fish. Pat. Cas. 630.....	415, 416. A.
Rogers <i>v.</i> Beecher.....	18 Off. Gaz. 793.....	417. A.
Rogers <i>v.</i> Riessner.....	30 Fed. Rep. 525.....	599. A.
Russell <i>v.</i> Cowley.....	Web. Pat. Cas. 470 [1 Am. &	
	Eng. 489].....	358. A.
Russell <i>v.</i> Place.....	94 U. S. 606 [11 Am. & Eng.	
	226].....	576. A.
Russell & E. Mfg. Co. <i>v.</i>		
Mallory.....	10 Blatch. 141.....	539. A.
Saint Louis Stamping Co.		
<i>v.</i> Quinby.....	4 Ban. & Ard. 192.....	329. A.
Sargent <i>v.</i> Hall Safe and		
Lock Co.....	114 U. S. 63 [15 Am. & Eng.	
	573].....	594. Opin.
Schumacher <i>v.</i> Cornell..	96 U. S. 549 [11 Am. & Eng.	
	443].....	556. Opin.
Seimens <i>v.</i> Sellers.....	123 U. S. 276 [17 Am. & Eng.	
	284].....	517. Opin.
Seymour <i>v.</i> McCormick..	19 How. 106 [6 Am. & Eng.	
	282].....	550, 621. A.
Seymour <i>v.</i> Marsh.....	2 Off. Gaz. 675.....	551. A.
Seymour <i>v.</i> Osborne.....	11 Wall. 516 [8 Am. & Eng.	
	290].....	344, 416, 538, 550, 551, 576. A.

## TABLE OF CITATIONS.

Citation.	Where reported.	Page, cited in this Vol.
<i>Shaw v. Colwell Lead Co.</i>	11 Fed. Rep. 711.....	589. A.
<i>Sharon v. Hill</i> .....	22 Fed. Rep. 28.....	608. A.
<i>Shepard v. Carrigan</i> .....	116 U. S. 593 [16 Am. & Eng. 235]..	594. Opin.
<i>Shuter v. Davis</i> .....	16 Fed. Rep. 564.....	576. Opin.
<i>Silsby v. Foot</i> .....	14 How. 218 [5 Am. & Eng. 411].....	620. A.
<i>Simpson v. Mad River R. R. Co.</i> .....	6 McLean 603.....	589. A.
<i>Sinclair v. Backus</i> .....	5 Ban. & Ard. 81, 83, 84.....	623. A.
<i>Sizer v. Many</i> .....	16 How. 98 [6 Am. & Eng. 189].....	599. A.
<i>Slawson v. Grand Street R. R. Co.</i> .....	107 U. S. 649 [14 Am. & Eng. 475].....	594. Opin.
<i>Slemmer's Appeal</i> .....	58 Pa. 155.....	590. A.
<i>Smith v. Fay</i> .....	6 Fish. Pat. Cas. 446... ..	416. A.
<i>Smith v. Goodyear Dental Vulcanite Co.</i> .....	93 U. S. 486 [11 Am. & Eng. 1].....	538, 551, 576. A.
<i>Smith v. Nichols</i> .....	21 Wall. 118 [9 Am. & Eng. 425].....	358. A.
<i>Smith v. Whitman</i> .....	6 Allen, 564.....	417. A.
<i>Snow v. Papley</i> .....	13 Off. Gaz. 548.....	416. A.
<i>Standard Measuring Ma- chine v. Teague</i> .....	15 Fed. Rep. 390.....	417. A.
<i>Stanley v. Hewitt</i> .....	17 Frank Jr. 2d Series 165... ..	589. A.
<i>Stearns v. Barrett</i> .....	1 Mason, 153; 1 Robb Pat. Cas. 115.....	590. A.
<i>Stevens v. Pritchard</i> .....	10 Off. Gaz. 505.....	550. A.
<i>Stilwell &amp; B. Mfg. Co. v. Cincinnati Gaslight &amp; Coke Co.</i> .....	1 Ban. & Ard. 610.....	416. A.
<i>Story, Eq. Pl.</i> .....	2 694.....	550. A.
<i>Swain Turbine &amp; Mfg. Co. v. Ladd</i> .....	102 U. S. 412 [13 Am. & Eng. 1].....	552, 621. A.
<i>Swift v. Whisen</i> .....	3 Fish. Pat. Cas. 360.....	590. A.
<i>Taylor v. Archer</i> .....	8 Blatch. 318.....	620. A.
<i>Thayer v. Hart</i> .....	20 Fed. Rep. 693.....	417. A.
<i>The James Martin</i> .....	5 Hughes 448 .....	417. A.
<i>The Santissima Trinidad</i>	7 Wheat. 283, 339.....	622. A.
<i>Thompson v. Boisselier</i>	114 U. S. 1 [15 Am. & Eng. 549].....	593. Opin.
<i>Thomas v. Shoe Machin- ery Mfg. Co.</i> .....	16 Off. Gaz. 541.....	551. A.



TABLE OF CITATIONS.

xxvii

Citation.	Where reported.	Page, cited in this V. l.
Thomas <i>v.</i> Wooldridge.	23 Wall. 283	599. A.
Tilghman <i>v.</i> Proctor.	102 U. S. 708 [13 Am. & Eng. 29]	475. Opin.
Tilghman <i>v.</i> Proctor.	102 U. S. 729 [13 Am. & Eng. 29]	316, 358, 456. A.
Tilghman <i>v.</i> Werk.	1 Bond. 511	589. A.
Tobey <i>v.</i> Leonard.	2 Cliff. 40, 50, 51	622. A.
Torrent & Arms Lumber Co. <i>v.</i> Rodgers.	112 U. S. 659 [15 Am. & Eng. 396]	621. A.
Treadwell <i>v.</i> Parrot.	3 Fish. Pat. Cas. 124	329. A.
Tuck <i>v.</i> Bramhill.	6 Blatch. 95	620. A.
Tucker <i>v.</i> Tucker Mfg. Co.	4 Cliff. 397	550. A.
Turner & S. Mfg. Co. <i>v.</i> Dover Stamping Co.	111 U. S. 319 [15 Am. & Eng. 238]	622. A.
Turrill <i>v.</i> Railroad.	1 Wall. 491 [11 Am. & Eng. 235]	612. A.
Tyler <i>v.</i> Boston.	7 Wall. 327 [8 Am. & Eng. 1]	339. A.
Union Paper Bag Machine Co. <i>v.</i> Murphy.	97 U. S. 120 [11 Am. & Eng. 494]	539. A.
Union Paper Collar Co. <i>v.</i> Van Dusen.	23 Wall. 562 [10 Am. & Eng. 156]	538. A.
Union Sugar Refinery <i>v.</i> Matthiesson.	3 Cliff. 639, 654	622. A.
Union Water-Meter Co. <i>v.</i> Desper.	101 U. S. 332 [12 Am. & Eng. 380]	540. Opin.
U. S. & Foreign Salamander Felting Co. <i>v.</i> Asbestos Felting Co.	18 Blatch. 312	576. A.
U. S. & Foreign Salamander Felting Co. <i>v.</i> Haven.	3 Dill. 131	551. A.
U. S. Stamping Co. <i>v.</i> Jewett.	18 Blatch. 469	417. A.
U. S. Stamping Co. <i>v.</i> King.	17 Blatch. 55	576. A.
Vance <i>v.</i> Campbell.	1 Fish. Pat. Cas. 483	589. A.
Vance <i>v.</i> Campbell.	1 Black, 427 [7 Am. & Eng. 117]	550. A.
Walk. Pat.	307	600. A.
Walker, Patents.	605	550. A.
Walker, Patents.	76	576. A.

Citation.	Where reported.	Page, cited in this Vol.
Walk. Patents.....	§§ 50, 51.....	590. A.
Walk. Patents.....	§ 388.....	599. A.
Wakeman v. Corcoran...	L. R. 13 Ch. Div. 65.....	339. A.
Wallace v. Holmes.....	5 Fish. Pat. Cas. 37.....	359. A.
Washburn v. Gould.....	2 Robb Pat. Cas. 2c6; 3 Story, 122.....	416. A.
Waterbury Brass Co. v. Miller.....	9 Blatch. 77.....	358. A.
Webster Loom Co. v. Hig- gins.....	105 U. S. 580 [14 Am. & Eng. 70].....	478. Opin.
Webster Loom Co. v. Hig- gins.....	105 U. S. 580 [14 Am. & Eng. 70].....	417, 538, 539, 576. A.
Westlake v. Cartter.....	6 Fish. Pat. Cas. 519.....	589. A.
Western Union Tel. Co. v. Baltimore & O. Tel. Co.	25 Fed. Rep. 32.....	551. A.
White v. Allen.....	2 Fish. Pat. Cas. 453.....	416. A.
White v. Dunbar.....	119 U. S. 47 [16 Am. & Eng. . 397].....	622. A.
White v. Dunbar.....	119 U. S. 47 [16 Am. & Eng. 397].....	594. Opin.
White v. Lee.....	14 Fed. Rep. 789.....	599. A.
Whiteley v. Swayne.....	7 Wall. 687 [8 Am. & Eng. 70].....	348, 590. A.
Wilbur v. Beecher.....	2 Blatch. 137.....	589. A.
Willett v. Fister.....	18 Wall. 91.....	417, 623. A.
Wilson v. Rousseau.....	4 How. 646 [4 Am. & Eng. 436].....	621. A.
Wilson v. Sandford.....	10 How. 99 [5 Am. & Eng. 122].....	599. A.
Wilson v. Sandford.....	10 How. 99 [5 Am. & Eng. 122].....	602. Opin.
Wilson v. Sherman.....	1 Blatch. 538.....	600. A.
Winans v. Denmead.....	15 How. 330 [6 Am. & Eng. 107].....	357. A.
Winans v. N. Y. & E. R. R. Co.....	21 How. 88 [6 Am. & Eng. 440].....	620. A.
Winans v. Schenectady & T. R. R. Co.....	2 Blatch. 279.....	620, 621. A.
Wing v. Anthony.....	106 U. S. 142 [14 Am. & Eng. 188].....	621. A.
Wing v. Richardson.....	2 Cliff. 449, 450.....	623. A.
Wintermute v. Redington	1 Fish. Pat. Cas. 239.....	589. A.
Wood v. Cleveland Roll- ing Mill Co.....	4 Fish. Pat. Cas. 550.....	415, 416. A.

## TABLE OF CITATIONS.

xxix

Citation.	Where reported.	Page, cited in this Vol.
Wood <i>v.</i> Underhill.....	5 How. 1 [4 Am. & Eng. 551].	339. A.
Wood <i>v.</i> Wells .....	6 Fish. Pat. Cas. 385.....	600. A.
Woodworth <i>v.</i> Cook.....	2 Blatch. 160.....	600. A.
Woodman <i>v.</i> Stimpson..	3 Fish. Pat. Cas. 98.....	329, 417. A.
Woodworth <i>v.</i> Weed....	1 Blatch. 165.....	600. A.
Wollensak <i>v.</i> Reiher....	115 U. S. 96 [16 Am. & Eng. 162].....	622. A.
Worswick Mfg. Co. <i>v.</i> Buffalo.....	20 Fed. Rep. 128.....	417. A.
Yale Lock Mfg. Co. <i>v.</i> Greenleaf.....	117 U. S. 554 [16 Am. & Eng. 303].....	593. Opin.
Yale Lock Mfg. Co. <i>v.</i> James.....	125 U. S. 447 [17 Am. & Eng. 603].....	557. Opin.
Yale Lock Mfg. Co. <i>v.</i> Sargent.....	117 U. S. 373 [16 Am. & Eng. 264].....	546. Opin.
Zeigler <i>v.</i> Hopkins.....	117 U. S. 686.....	599. A.

## TABLE OF ABBREVIATIONS

OF THE TITLE OF REPORTS AND WORKS OF LAW USED IN  
THIS VOLUME.

---

Abb. Pat. Laws.....	Abbott's Patent Laws of all Nations.
Abb. U. S.....	Abbott, U. S. Circuit Court.
Abb. U. S. Prac.....	Abbott's U. S. Practice Cases.
Ad. & Ell. (N. S.).....	Adolphus & Ellis, England, K. B.
Alb. L. J.....	Albany Law Journal.
Am. Law. Jour.....	American Law Journal.
Am. Law. Reg. (N. S.)....	American Law Register (New Series).
Am. & Eng.....	American & English Patent Cases.
App. Cas.....	Appeal Cases, English Law Reports.
Ark.....	Arkansas Reports.
Atk.....	Atkyn Chancery Reports, England.
Att'y Gen.....	Attorney General's Decisions.
B. & A.....	Banning & Arden's Patent Cases, U. S.
B. & Ad.....	Barnewall & Adolphus, England, K. B.
B. & Ald.....	Barnewall & Alderson, England, K. B.
B. & C.....	Barnewall & Cresswell, England, K. B.
Bald.....	Baldwin, U. S. Circuit Court.
Ban. & Ard.....	Banning & Arden's Patent Cases, U. S.
Barb.....	Barbour's New York Chancery Reports.
Barb. Ch. Pr.....	Barbour's Chancery Practice.
Best & S.....	Best & Smith, England, Q. B.
Bing. (N. C.).....	Bingham's New Cases, England, C. P.
Binn.....	Binney's Pennsylvania Reports.
Biss.....	Bissell, U. S. Circuit Court.
Black.....	Black, U. S. Supreme Court.
Blatch.....	Blatchford, U. S. Circuit Court.
B. Mon.....	Ben. Monroe's Kentucky Reports.
Bond.....	Bond, U. S. Circuit Court.
Bos. & P. N. R.....	Bosanquet & Puller's New Reports, England.
Bradw.....	Bradwell's Illinois Reports.
Brews.....	Brewster's Pennsylvania Reports.
Bright. Fed. Dig.....	Brightly's Federal Digest.
Brock.....	Brockenbrough, U. S. Circuit Court.
Brodix.....	Brodix's American & English Patent Cases.
Bump.....	Bump on the Law of Patents.

TABLE OF ABBREVIATIONS.

xxxi

C. B. (N. S.).....	Common Bench Reports, New Series.
C. D.....	Commissioner of Patents' Decisions, U. S.
C. P.....	Common Pleas, England.
C. & F.....	Clark & Finnelly's House of Lords Reports, England.
Car. & Kir.....	Carrington & Kirwan, England, N. P.
Car. & M.....	Carrington & Marshman's English Nisi Prius Reports.
Ch. Div.....	Chancery Division, English Law Reports.
Cliff.....	Clifford, U. S. Circuit Court.
Com. Bench.....	Common Bench Reports, England.
Com. Dec.....	Commissioner of Patents' Decisions, U. S.
Cond. (Reps.) .....	Peters' Condensed Reports, U. S. Supreme Court.
Cow.....	Cowen's New York Reports.
Cranch.....	Cranch, U. S. Supreme Court.
Ct. of Claims.....	Court of Claims, U. S.
Curt.....	Curtis, U. S. Circuit Court.
Curtis on Pats.....	Curtis on Patents, U. S.
Cush.....	Cushing's Massachusetts Reports.
D. & R.....	Dowling & Rylands, England.
Dall.....	Dallas, U. S. Circuit Court.
Dan. Ch. Pr.....	Daniell's Chancery Practice.
Dav.....	Davies' Patent Cases, England.
De G. M. & G.....	De Gex, Macnaghten & Gordon, England, Chancery.
Denio.....	Denio's New York Reports.
Dick.....	Dickens' English Chancery Reports.
Dill.....	Dillon, U. S. Circuit Court.
E. C. L. R.....	English Common Law Reports.
East.....	East, England, K. B.
Ell. & Bl.....	Ellis & Blackburn, England, Q. B.
Eng. C. L. (C. B. N. S.).....	English Common Law Reports.
Eng. L. & E.....	English Law & Equity Reports.
Exch. W. H. & G.....	Exchequer Reports (Welsby, Hurlstone & Gordon), England.
Fed. Rep.....	Federal Reporter, U. S.
Fish.....	Fisher's Patent Cases, U. S.
Fish. Pat. Rep.....	Fisher's Patent Reports, U. S.
Flipp.....	Flippin, U. S. Circuit Court.
Gall.....	Garrison, U. S. Circuit Court.
Gen. Ord. Ch.....	General Order of the High Court of Chancery.
Gill.....	Gill's Maryland Reports.
Godson on Pats.....	Godson on Patents, England.
Gratt.....	Gratton's Virginia Reports.
Gray.....	Gray's Massachusetts Reports.
Greenl. Ev.....	Greenleaf on Evidence.

H. Bl.....	Henry Blackstone, England, C. P.
H. of L.....	House of Lords' Cases.
H. & N.....	Hurlstone & Norman, England, Exch.
Halst. Ch.....	Halstead's New Jersey Reports.
Hare.....	Hare's Vice-Chancellor's Reports, England.
Har. & Gill.....	Harris & Gill's Maryland Reports.
Hemp.....	Hempstead, U. S. Circuit Court.
High Ex. Rem.....	High on Extraordinary Legal Remedies.
Hill ..	Hill's New York Reports.
Hind. Pat ..	Hindmarch on Patents, England
Hoff. Ch. Pr.....	Hoffman's Chancery Practice.
Holmes.....	Holmes, U. S. Circuit Court.
Hopkins.....	Hopkins' New York Reports.
How.....	Howard, U. S. Supreme Court.
Hughes.....	Hughes, U. S. Circuit Court.
Hurls. & Colt.....	Hurlstone & Coltman, England, Exch.
Hurls. & Nor.....	Hurlstone & Norman, England, Exch.
Ir. Ch.....	Irish Chancery Reports.
Ill.....	Illinois Reports.
Iowa.....	Iowa Reports.
J. & W.....	Jacob & Walker, Chancery Reports, England.
J. B. Moore.....	J. B. Moore, England, C. P.
Jacob.....	Jacob's Chancery Reports, England.
Johns.....	Johnson's New York Reports.
Jur. (N. S.).....	The Jurist, New Series, London.
Kerr Inj.....	Kerr on Injunctions.
L. ed.....	Lawyer's Edition of Supreme Court Reports.
L. J. (N. S.) C. P.....	Law Journal, New Series, Common Pleas.
L. J. (N. S.) Q. B.....	The Law Journal, New Series, London, Queen's Bench.
L. R. C. P.....	English Law Reports, Common Pleas.
L. R. Ch. App.....	English Law Reports, Chancery Appeals.
L. R. Eq.....	English Law Reports, Equity.
L. R. Q. B. Div.....	English Law Reports, Queen's Bench Di- vision.
L. Times (N. S.).....	Law Times, New Series.
Law's Dig.....	Law's Digest, London.
Law T. (N. S.).....	Law Times Reports, New Series
Leg. Int.....	Legal Intelligencer.
Lindley Part.....	Lindley Laws of Partnership.
Lowell.....	Lowell, U. S. District Court.
M. & Cr.....	Mylne & Craig, England, Ch.
M. & W.....	Meeson & Welsby, England, Exch.
MacA.....	MacArthur's District of Columbia Reports.
MacA. & McK.....	MacArthur & Mackey.
McAll.....	McAllister, U. S. Circuit Court.
McC.....	McCrary, U. S. Circuit Court.

TABLE OF ABBREVIATIONS.

xxxiii

McL.....	McLean, U. S. Circuit Court.
Mackey.....	Mackey, U. S. Circuit Court.
Man. G. & Scott.....	Manning, Granger & Scott, England, C. P.
Mann. & G.....	Manning & Granger's English Common Pleas Reports.
Marsh.....	Marshall, England, C. P.
Mas.....	Mason, U. S. Circuit Court.
Mass.....	Massachusetts Reports.
Me.....	Maine Reports.
Mees. & W.....	Meeson & Welsby, England, Exch.
Merwin on Pat. Invt.....	Merwin on Patentability of Inventions.
Met.....	Metcalf's Massachusetts Reports.
Mitf. Eq. Pl.....	Mitford's Equity Pleading.
Mod.....	Modern Reports, England, K. B.
Moore & S.....	Moore & Scott, England, C. P.
Ms. D. C.....	Manuscript Cases, District of Columbia.
Mumf.....	Mumford's Virginia Reports.
Neb.....	Nebraska Reports.
N. J. L.....	New Jersey Law Reports.
N. Y.....	New York Court of Appeals Reports.
New Eng. R.....	New England Reporter.
O. G.....	Official Gazette of Patent Office, U. S.
Off. Gaz.....	Official Gazette of Patent Office, U. S.
Otto.....	Otto, U. S. Supreme Court.
P. Wm.....	Peete Williams' Reports, England.
Pa.....	Pennsylvania Reports.
Pac. L. R.....	Pacific Law Reporter.
Paige Ch. R.....	Paige's New York Chancery Reports.
Paine.....	Paine, U. S. Circuit Court.
Pet.....	Peters, U. S. Supreme Court.
Phila.....	Philadelphia Reports.
Pick.....	Pickering's Massachusetts Reports.
Pitta. R.....	Pittsburgh Reports.
Pott. Dwarris.....	Potter's Ed. of Dwarris on Statutes.
Q. B.....	Queen's Bench Reports.
Q. B. Div.....	Queen's Bench Division, Law Reports, Eng- land.
R. & M.....	Russell & Mylne, England, Ch.
Rep.....	The Reporter, U. S.
Robb.....	Robb's Patent Cases.
Salk.....	Salkeld, England, K. B.
Sandf.....	Sandford's New York Superior Court.
Sawy.....	Sawyer, U. S. Circuit Court.
Scam.....	Scammon's Illinois Reports.
Scott (N. R.).....	Scott's New Reports, England, C. P.
Seld.....	Selden's Reports (5-10 N. Y. Court of Ap- peals).

Sim. & S.....	Simon's & Stuart's English Vice Chancery Reports.
Sm. Lead. Cas.....	Smith's Leading Cases.
Smith Ch. Pract.....	Smith's Chancery Practice.
Story.....	Story, U. S. Circuit Court.
Story Eq. Jur.....	Story on Equity Jurisprudence.
Sumn.....	Sumner, U. S. Circuit Court.
Sup. Ct. Rep. N. Y.....	Supreme Court Reports, New York.
T. R.....	Term Reports (Durnford & East), England.
Taney.....	Taney, U. S. Circuit Court.
Taunt.....	Taunton, England, C. P.
Term R.....	Term Reports (Durnford & East), England.
Tex.....	Texas Reports.
Ure Dict.....	Ure's Dictionary of Arts.
U. S.....	United States Supreme Court Reports.
U. S. Law Jour.....	United States Law Journal.
Ves.....	Vesey, England, Ch.
Vern.....	Vernon, England, Ch.
Vt.....	Vermont Reports.
W. & M.....	Woodbury & Minot, U. S. Circuit Court.
W. Va. Rep.....	West Virginia Reporter.
Walker on Pats.....	Walker on Patents.
Wall.....	Wallace, U. S. Supreme Court.
Wall, Jr.....	Wallace, Jr., U. S. Circuit Court.
Wash.....	Washington, U. S. Circuit Court.
Watts.....	Watts' Pennsylvania Reports.
Weekly Reps.....	Weekly Reporter, London.
Watts & S.....	Watts & Sergeant's Pennsylvania Reports.
Web. P. C.....	Webster's Patent Cases, England.
Web. on Sub. Mat. of Pats.....	Webster on Subject Matter of Patents.
Wend.....	Wendell's New York Reports.
West H. L.....	West's House of Lords Reports, England.
Whart. Dig.....	Wharton's Pennsylvania Digest.
Wheat.....	Wheaton, U. S. Supreme Court.
Whit.....	Whitman's Patent Cases, U. S.
Wood. & M.....	Woodbury & Minot, U. S. Circuit Court.
Woods.....	Woods, U. S. Circuit Court.



**NAMES OF JUSTICES.**

WHOSE DECISIONS ARE REPORTED IN THIS VOLUME.

---

- Mr. Justice Bradley. (Dissenting Opinion.) Telephone Cases, p. 518.  
 Mr. Justice Blatchford. Mosler Safe and Lock Co. *v.* Mosler, p. 577.  
 \_\_\_\_\_ Hendy *v.* Golden State, p. 590.  
 \_\_\_\_\_ Joyce *v.* Chillicothe Foundry, p. 613.  
 \_\_\_\_\_ Flower *v.* City of Detroit, p. 625.  
 Mr. Justice Gray. St. Paul Plow Works *v.* Starling, p. 600.  
 \_\_\_\_\_ Holland *v.* Shipley, p. 609.  
 \_\_\_\_\_ Cornell *v.* Weidner, p. 552.  
 Mr. Chief Justice Waite. Telephone Cases, p. 472.

## NAMES OF COUNSEL.

---

### APPEARING IN CASES REPORTED IN THIS VOLUME.

- Mr. Henry C. Andrews. Overland Telephone Co., p. 393.  
 \_\_\_\_\_ Overland Telephone Co., p. 336.  
 \_\_\_\_\_ People's Telephone Co., p. 393.  
 \_\_\_\_\_ People's Telephone Co., p. 336.
- Mr. Edward Boyd, for Appellees. Holland *v.* Shipley, p. 608.  
 \_\_\_\_\_ for Appellant. Joyce *v.* Chillicothe Foundry, p. 612.
- Mr. Causten Browne, Appellants. Telephone Cases, p. 279.  
 \_\_\_\_\_ Dolbear. Telephone Cases, p. 453.
- Mr. Chas. S. Careins. St. Paul Plow Works *v.* Starling, p. 598.
- Mr. Melville Church. Overland Telephone Co., p. 336.  
 \_\_\_\_\_ People's Telephone Co., p. 336.  
 \_\_\_\_\_ Overland Telephone Co., p. 393.  
 \_\_\_\_\_ People's Telephone Co., p. 393.
- Mr. Charles P. Crosby. Overland Telephone Co., p. 336.  
 \_\_\_\_\_ Overland Telephone Co., p. 279.  
 \_\_\_\_\_ Overland Telephone Co., p. 393.  
 \_\_\_\_\_ People's Telephone Co., p. 393.  
 \_\_\_\_\_ People's Telephone Co., p. 336.
- Mr. Edward N. Dickerson. American Bell Telephone Co., p. 144.  
 \_\_\_\_\_ American Bell Telephone Co., p. 279.  
 \_\_\_\_\_ American Bell Telephone Co., p. 345.
- Mr. Don. M. Dickinson. Overland Telephone Co., p. 393.  
 \_\_\_\_\_ Overland Telephone Co., p. 336.  
 \_\_\_\_\_ Overland Telephone Co., p. 279.  
 \_\_\_\_\_ People's Telephone Co., p. 393.  
 \_\_\_\_\_ People's Telephone Co., p. 336.  
 \_\_\_\_\_ People's Telephone Co., p. 279.
- Mr. T. S. E. Dixon. Overland Telephone Co., p. 336.  
 \_\_\_\_\_ Overland Telephone Co., p. 393.  
 \_\_\_\_\_ People's Telephone Co., p. 336.  
 \_\_\_\_\_ People's Telephone Co., p. 393.
- Mr. H. D. Donnelly. Molecular Co., p. 300.
- Mr. George F. Edmunds. Overland Telephone Co., p. 279.  
 \_\_\_\_\_ Overland Telephone Co., p. 336.  
 \_\_\_\_\_ Overland Telephone Co., p. 393.

- Mr. George F. Edmunds. Overland Telephone Co., p. 400.  
 \_\_\_\_\_ People's Telephone Co., p. 336.  
 \_\_\_\_\_ People's Telephone Co., p. 279.  
 \_\_\_\_\_ People's Telephone Co., p. 393.  
 \_\_\_\_\_ People's Telephone Co., p. 408.
- Mr. D. S. Frackelton. St. Paul Plow Works *v.* Starling, p. 598.
- Mr. Edward J. Hill, for Appellants. Flower *v.* City of Detroit, p. 622.
- Mr. Lysander Hill. Overland Telephone Co., p. 336.  
 \_\_\_\_\_ Overland Telephone Co., p. 279.  
 \_\_\_\_\_ Overland Telephone Co., p. 393.  
 \_\_\_\_\_ People's Telephone Co., p. 279.  
 \_\_\_\_\_ People's Telephone Co., p. 393.  
 \_\_\_\_\_ People's Telephone Co., p. 336.
- Mr. William W. Ker. Clay Commercial Telephone Co., p. 390.  
 \_\_\_\_\_ Clay Commercial Telephone Co., p. 279.
- Mr. J. P. Langhorne, for Appellant. Hendy *v.* Golden State, p. 589.
- Mr. George H. Lothrop, for Appellee. Cornell *v.* Weidner, p. 551.
- Mr. Grosvenor P. Lowrey. Molecular Telephone Co., p. 279.  
 \_\_\_\_\_ Molecular Telephone Co., p. 300.
- Mr. James E. Maynadier, for Appellants. Telephone Cases, p. 279.
- Mr. J. W. Merriam, for Appellant. Cornell *v.* Weidner, p. 549.
- Mr. J. H. Miller, for Appellant. Hendy *v.* Golden State, p. 589.
- Mr. James Moore, for Appellees. Mosler Safe and Lock Co. *v.* Mosler,  
 p. 557.
- Mr. George J. Murray, for Appellant. Holland *v.* Shipley, p. 608.  
 \_\_\_\_\_ for Appellant. Mosler Safe and Lock Co. *v.* Mos-  
 ler, p. 576.
- Mr. Wheeler H. Peckham. Molecular Telephone Co., p. 461.  
 \_\_\_\_\_ Molecular Telephone Co., p. 279.  
 \_\_\_\_\_ Molecular Telephone Co., p. 300.
- Mr. George L. Roberts, for Appellees. Flower *v.* City of Detroit, p. 623.
- Mr. Chauncey Smith. American Bell Telephone Co., p. 345.
- Mr. James J. Storrow. American Bell Telephone Co., p. 345.  
 \_\_\_\_\_ American Bell Telephone Co., p. 279.
- Mr. William P. Wells, for Appellant. Forncrook *v.* Root, p. 537.
- Mr. M. A. Wheaton, for Appellees. Hendy *v.* Golden State, p. 589.
- Mr. John H. Whipple, for Appellant. Cornell *v.* Weidner, p. 549.
- Mr. E. E. Wood, for Appellees. Holland *v.* Shipley, p. 608.  
 \_\_\_\_\_ for Appellant. Joyce *v.* Chillicothe Foundry, p. 612.

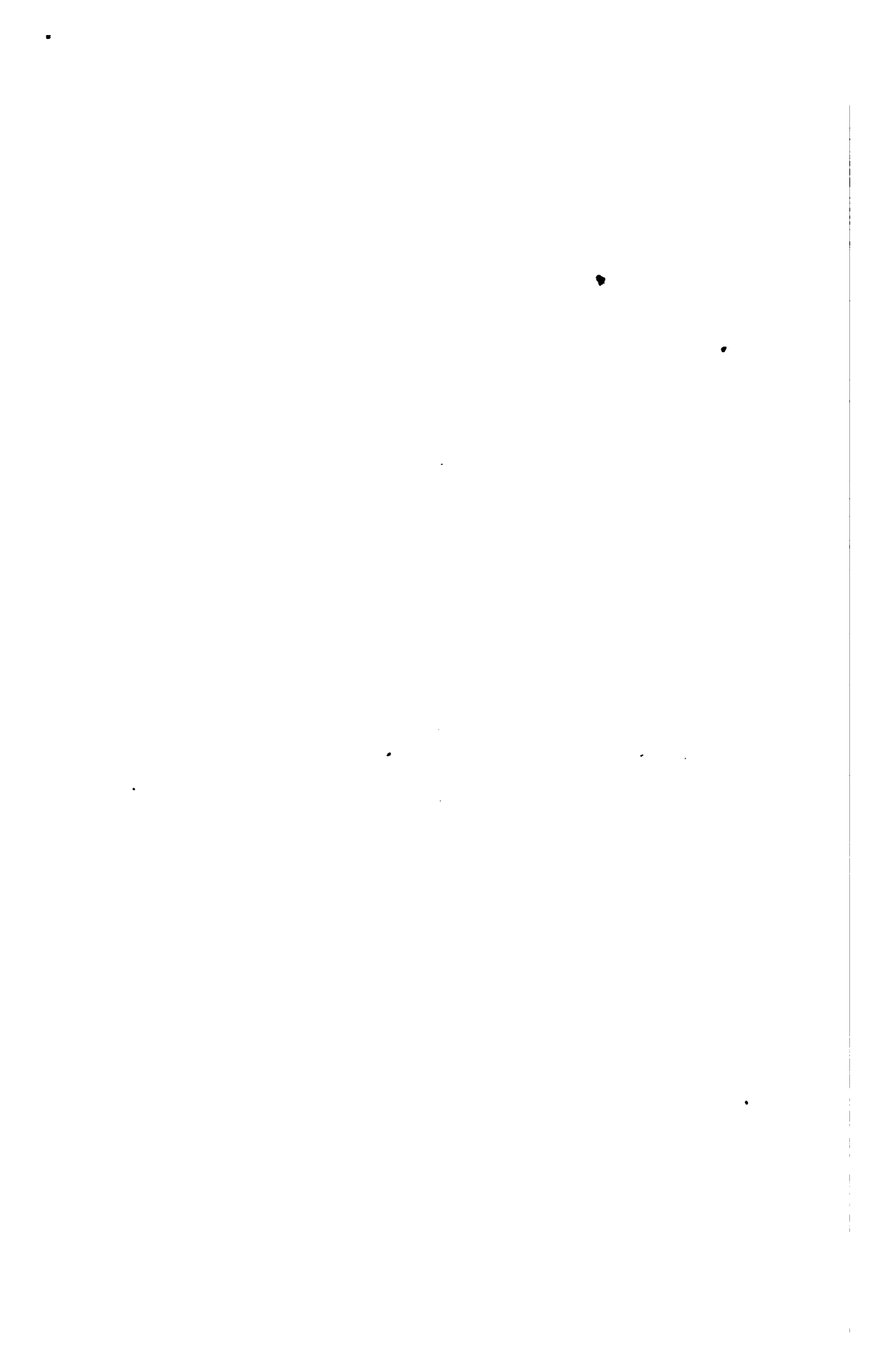

**DECISIONS**  
OF  
**THE SUPREME COURT**  
OF  
**THE UNITED STATES**  
IN  
**PATENT CASES.**

---

**TELEPHONE CASES.\***

**AMOS E. DOLBEAR ET AL, APPELLANTS, v. AMERICAN BELL TELEPHONE COMPANY.**

**MOLECULAR TELEPHONE COMPANY ET AL, APPELLANTS, v. SAME ET AL.**

**AMERICAN BELL TELEPHONE COMPANY ET AL, APPELLANTS, v. MOLECULAR TELEPHONE COMPANY ET AL.**

**CLAY COMMERCIAL TELEPHONE COMPANY ET AL, APPELLANTS, v. AMERICAN BELL TELEPHONE COMPANY ET AL.**

**PEOPLE'S TELEPHONE COMPANY ET AL, APPELLANTS, v. SAME.**

**OVERLAND TELEPHONE COMPANY ET AL, APPELLANTS, v. SAME.**

\* See Explanation of Notes, page III.

## Syllabus.

126, U. S. 1-554. Oct. Term, 1887.

[Bk. 31, L. ed. 863; 43 O. G. 377.]

Argued, January 24, 25, 26, 27, 28, 31; February 1, 2, 3, 4,  
7, 8, 1887. Decided, March 19, 1888.

*Particular patents construed, sustained and infringed. Process and apparatus. Art. Patentability of process. Principle. Novelty. Evidence of incorporation. Date of prior foreign patent recited in United States patent.*

1. Claim 5 of letters patent, No. 174,465, granted to Alexander G. Bell, March 7, 1876, for Improvements in Telegraphy, for "The method of and apparatus for transmitting vocal or other sounds telegraphically, as herein described, by causing electrical undulations similar in form to the vibrations of the air accompanying the said vocal or other sounds, substantially as set forth," construed to be for the art and for the apparatus; *held*, that "articulate speech" was one of the "vocal or other sounds" referred to in the claim, though not mentioned by name in the patent. *Held*, to involve discovery in finding the art or process which consists in gradually changing the intensity of a continuous electrical current so as to make it correspond exactly to the changes in the density of the air caused by the sound of the voice, and invention in devising means to make it useful—devising a way in which these changes of density could be made and speech actually transmitted to put the art in a condition for practical use. (p. 472.)
2. An art and a process are the same thing under the patent law. (p. 474.)
3. A discoverer of a new art, process or method is entitled to a patent for the same, and for the means he has devised to make the discovery of actual value. Other inventors may compete with him for the ways of giving effect to the discovery, but the new art he has found will belong to him and those claiming under him during the life of his patent (p. 474.)

## Syllabus.

4. A patent for the art (R. S. Sec. 4886) does not necessarily involve a patent for the particular means for doing it, and the mention of means in the specification is only necessary to show that the art can be used to advantage. (p. 475.)
5. This 5th claim is not in opposition to the decision in *O'Reilly v. Morse*, but is sustained by it, as this claim is not for the use of a current of electricity in its natural state as it comes from the battery, but for putting a continuous current in a closed circuit into a certain specific condition, suited to the transmission of vocal and other sounds, and using it in that condition for that purpose. It may be that electricity cannot be used at all for the transmission of speech except in the way Bell has discovered, and that therefore, practically, his patent gives him its exclusive use for that purpose; but that does not make his claim one for the use of electricity distinct from the particular process with which it is connected in his patent. (p. 476.)
6. Where patentee, when he applied for this patent (the telephone and apparatus) *Improvements in Telegraphy*, and which was construed to be both for the art and for the apparatus, had never actually transmitted telegraphically spoken words, so that they could be distinctly heard and understood at the receiving end of his line; and the particular instrument which he had, and which he used in his experiments, did not, under the circumstances in which it was tried, reproduce the words spoken so that they could be clearly understood; but proof was abundant and convincing that other instruments carefully constructed and made exactly in accordance with the specification, and without any addition whatever, had operated and would operate successfully; *held*, that it had attained the practical development necessary to make it patentable. (p. 477.)
7. The law does not require that a discoverer or inventor, in order to get a patent for a process, must have succeeded in bringing his art to the highest degree of perfection. It is enough if he describes his method with sufficient clearness and precision to enable those skilled in the matter to understand what the process is, and also if he points out some practical way of putting it in operation. (p. 478.)

## Syllabus.

8. *Held*, that Bell's 5th claim is first for the process.
- 1st. The method of transmitting vocal or other sounds telegraphically as herein described, by causing electrical undulations similar in form to the vibrations of the air accompanying the said vocal or other sounds, substantially as set forth; and second for the apparatus:
- 2d. The apparatus for transmitting vocal or other sounds telegraphically, as herein described, by causing electrical undulations substantially as set forth. (p. 479.)
9. *Held*, that the Bell patent is not confined to a magneto-instrument and such modes of creating electrical undulations as could be produced by that form of apparatus. The words in the 5th claim—the “method herein described,” “in the manner substantially as set forth”—include both the magneto method and the variable resistance method. The current must be kept closed to be used successfully; but this does not necessarily imply that it must be so produced or so operated upon as to be incapable of being closed. There is nothing in the patent which requires it to be operated by instruments which are incapable of making the break. The patent is both for the magneto and variable resistance methods, and for the particular magneto apparatus which is described, or its equivalent. There is no patent for any variable resistance apparatus. (p. 479.)
10. The claim upon this broad construction is not “a claim for speech transmission by transmitting it—or, in other words, for all such doing of a thing as is provable by doing it.” No one before Bell knew how to put electricity in a certain condition for successful use in speech transmission. (p. 480.)
11. Where it was not contended that Reis had ever succeeded in actually transmitting speech, but only that his instrument was capable of it, if he had known how; and it appeared that he did not know how, and that all his experiments in that direction were failures; that he discovered how to produce musical tones; but did no more, using an intermittent or make and break current, a different method; *held*, that it did not anticipate Bell's discovery. (p. 482.)
12. Van der Weyde copied Reis, and it was not until after



## Syllabus.

- Bell's success that he found out how to use a Reis instrument so as to make it transmit speech. (p. 488.)
13. McDonough was anticipated by Reis, and in his application for a patent made a circuit-breaker so adjusted as to break the connection by the vibrations of the membrane, one of the elements of his invention. (p. 488.)
  14. Varley's English Patents of June 2, 1868, and October 8, 1870, describe a Morse key, or something equivalent, and there is implied an operation on the principle of the electric telegraph, viz.: by making and breaking the circuit. The terms "undulations" and "waves" are used in his specification and in an entirely different sense from Bell, and are not anticipations. (p. 488.)
  15. Considering the history of Drawbaugh's inventions as described in evidence with perfected apparatus prior to Bell's invention, and the conduct of Drawbaugh after Bell's telephone had been patented and had become notorious, and the fact that Drawbaugh brought forward and patented other inventions after Bell's telephone had become unsally talked about, and did not apply for a patent on his telephone until July, 1880, with other facts detailed at length, the Court comes to this conclusion, viz.: "We do not doubt that Drawbaugh may have conceived the idea that speech could be transmitted to a distance by means of electricity, and that he was experimenting upon that subject; but to hold that he had discovered the art of doing it before Bell did would be to construe testimony without regard to the ordinary laws that govern human conduct." (p. 489.)
  16. *Held*, that the 4th claim and the variable resistance method described in the specification were not fraudulently obtained from Gray's caveat and inserted into Bell's application subsequent to the filing of the same. The testimony reviewed. (p. 512.)
  17. Objection made to the sufficiency of the proof of the incorporation of the American Bell Telephone Company and of its title to the Bell patents; *held*, not well taken. Under the Act of the General Court of Massachusetts, Section 11 Chap. 224, the certificate of the Secretary of the Common-

## Syllabus.

wealth is made conclusive evidence of the existence of a corporation. (p. 516.)

18. Letters patent, No. 186,787, granted to Alexander Graham Bell, January 30, 1877, for Improvements in Electric Telegraphy; *held*, valid as to the 3d, 5th, 6th, 7th and 8th claims thereof and to have been infringed, and is not invalid for failure to bear the same date as his prior English patent of December 9, 1876; but its term only is limited thereby. (p. 517.)
19. The effect of Section 4887 of the Revised Statutes is not to render invalid an American patent by an English patent of an earlier date for the same invention, but only to limit its term. (p. 517.)
20. The 5th claim of letters patent, No. 186,787, for "The formation, in an electric telephone, such as herein shown and described, of a magnet with a coil upon the end or ends of the magnet nearest the plate," construed to be not for the magnet, but for the telephone, of which it forms a part. (p. 518.)

## [Citations in the opinion of the court:]

- Corning *v.* Burden, 15 How. 252 [6 Am. & Eng. 69]. p. 475.  
 Cochrane *v.* Deener, 94 U. S. 780 [11 Am. & Eng. 288.] p. 475.  
 Tilghman *v.* Proctor, 102 U. S. 707 [13 Am. & Eng. 29.] p. 475.  
 New Process Fermentation Co. *v.* Maus, 122 U. S. 413 [17 Am. & Eng. 157] p. 475.  
 O'Reilly *v.* Morse, 15 Hon. 62 [5 Am. & Eng. 483.] pp. 476, 517.  
 Webster Loom Co. *v.* Higgins, 105 U. S. 580 [14 Am. & Eng. 70.] p. 478.  
 Atlantic Works *v.* Brady, 107 U. S. 192 [14 Am. & Eng. 380.] p. 512.  
 Siemens *v.* Sellers, 123 U. S. 276 [17 Am. & Eng. 284] p. 517.

No. 10, the *Dolbear Case*, is an appeal from the Circuit Court of the United States for the District of Massachusetts. *Affirmed*.

Reported below in 15 Fed. Rep. 448, and 17 Fed. Rep. 604.

Nos. 361 and 362, in the *Molecular Case*, are appeals from the Circuit Court of the United States for the Southern District of New York. *Affirmed* so far as it is in favor of the Bell Company, and *reversed* so far as it is against that com-

## Infringement cases.

pany on the 5th claim of the patent of January 30, 1877, and a decree directed to that extent in its favor.

Reported below in 32 Fed. Rep. 214.

No. 709, the *Clay Commercial Case*, is an appeal from the Circuit Court of the United States for the Eastern District of Pennsylvania. *Affirmed.*

No. 770, the *People's Company Case*, is an appeal from the Circuit Court of the United States for the Southern District of New York. *Affirmed.*

Reported below in 22 Fed. Rep. 309, and 25 Fed. Rep. 725. See also 31 Fed. Rep. 729, and 27 Fed. Rep. 663.

No. 771, the *Overland Company's Case*, is an appeal from the Circuit Court of the United States for the Southern District of New York. *Affirmed.*

A statement of the proceedings in each of these cases is hereinafter given.

These actions were brought by the American Bell Telephone Company and others for infringement of two letters patent, issued to Alexander Graham Bell, of which the plaintiffs were owners, known as the Bell Telephone Patent, the one being No. 174,465, dated March 7, 1876, issued on an application sworn to January 20, 1876, and filed February 14, 1876, for "Improvements in Telegraphy," the other being No. 186,787, dated January 30, 1887, issued on an application filed January 15, 1887, for "Improvements in Electric Telephony." The decree in the Court below in each case was against the defendants, except in the case of the Molecular Telephone Company, in which a decree was entered for the complainants upon the 5th claim of said letters patent No. 174,465, and the 6th, 7th and 8th claims of said letters patent No. 186,787, and in favor of the defendants upon the 5th claim of the last named patent; both the defendants and the complainants appealed in that case from the portions of the decree decided against them severally. In each of the other cases the defendants appealed.

The following are copies of the drawings and specifications of Bell's two patents upon which the suits were brought:

## Statement of the case.

ALEXANDER GRAHAM BELL, OF SALEM,  
MASSACHUSETTS.

## . IMPROVEMENT IN TELEGRAPHY.

Specification forming part of Letters Patent, No. **174,465**, dated  
March 7, 1876; application filed February 14, 1876.

*To all whom it may concern:*

Be it known that I, ALEXANDER GRAHAM BELL, of Salem, Massachusetts, have invented certain new and useful improvements in telegraphy, of which the following is a specification:

In letters patent granted to me April 6, 1875, No. 161,739, I have described a method of, and apparatus for, transmitting two or more telegraphic signals simultaneously along a single wire by the employment of transmitting instruments, each of which occasions a succession of electrical impulses differing in rate from the others; and of receiving instruments, each tuned to a pitch at which it will be put in vibration to produce its fundamental note by one only of the transmitting instruments; and of vibratory circuit-breakers operating to convert the vibratory movement of the receiving instrument into a permanent make or break (as the case may be) of a local circuit, in which is placed a Morse sounder, register, or other telegraphic apparatus. I have also therein described a form of autograph telegraph based upon the action of the above-mentioned instruments.

In illustration of my method of multiple telegraphy, I have shown in the patent aforesaid, as one form of transmitting instrument, an electro-magnet having a steel-spring armature which is kept in vibration by the action of a local battery. This armature in vibrating makes and breaks the main circuit, producing an intermittent current upon the line-wire. I have found, however, that upon this plan the limit to the number of signals that can be sent simultaneously over the same wire is very speedily reached; for,

A. G. BELL.  
TELEGRAPHY.

No. 174,465.

Patented March 7, 1876.

Fig. 1

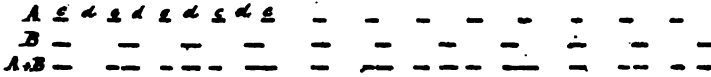

Fig. 2.

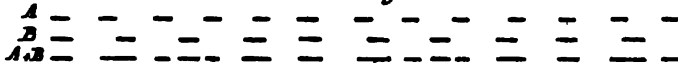

Fig. 3.

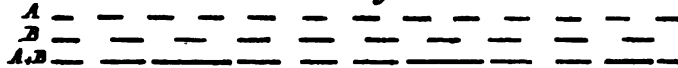

Fig. 4.

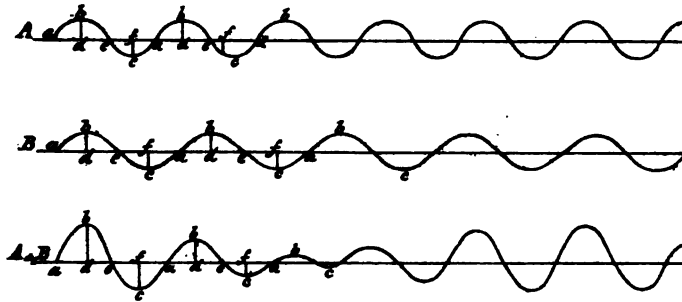
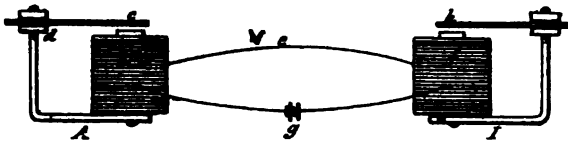

Fig. 5.



Witnesses:

*Ewell Forks,*  
*H. J. Hutchinson*

Inventor:

*A. Graham Bell*  
*by Atty. Wm. S. Packer*



A. G. BELL.  
TELEGRAPHY.

No. 174,465.

Patented March 7, 1876.

Fig 6.

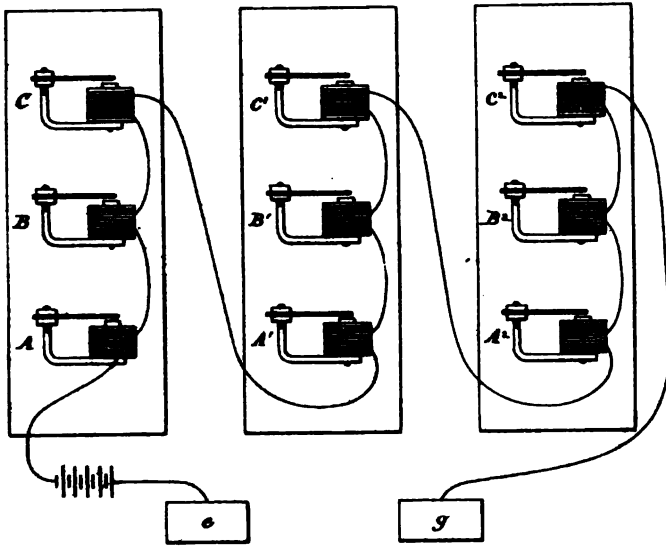
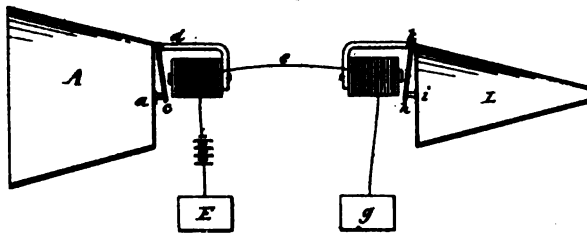

Fig 7.



Witnesses  
*Charles D. Smith*  
*H. J. Hutchinson*

Inventor:  
*A. Graham Bell*  
*by atty Allen Parley*





## Statement of the case.

when a number of transmitting instruments, having different rates of vibration, are simultaneously making and breaking the same circuit, the effect upon the main line is practically equivalent to one continuous current.

In a pending application for letters patent, filed in the United States Patent Office February 25, 1875, I have described two ways of producing the intermittent current—the one by actual make and break of contact, the other by alternately increasing and diminishing the intensity of the current without actually breaking the circuit. The current produced by the latter method I shall term, for distinction's sake, a pulsatory current.

My present invention consists in the employment of a vibratory or undulatory current of electricity in contradistinction to a merely intermittent or pulsatory current, and of a method of, and apparatus for, producing electrical undulations upon the line-wire.

The distinction between an undulatory and a pulsatory current will be understood by considering that electrical pulsations are caused by sudden or instantaneous changes of intensity, and that electrical undulations result from gradual changes of intensity exactly analogous to the changes in the density of air occasioned by simple pendulous vibrations. The electrical movement, like the aerial motion, can be represented by a sinusoidal curve or by the resultant of several sinusoidal curves.

Intermittent or pulsatory and undulatory currents may be of two kinds, accordingly as the successive impulses have all the same polarity or are alternately positive and negative.

The advantages I claim to derive from the use of an undulatory current in place of a merely intermittent one are, first, that a very much larger number of signals can be transmitted simultaneously on the same circuit; second, that a closed circuit and single main battery may be used; third, that communication in both directions is established without the necessity of special induction-coils; fourth, that cable dis-

## Statement of the case.

patches may be transmitted more rapidly than by means of an intermittent current or by the methods at present in use; for, as it is unnecessary to discharge the cable before a new signal can be made, the lagging of cable-signals is prevented; fifth, and that as the circuit is never broken, a spark-arrester becomes unnecessary.

It has long been known that when a permanent magnet is caused to approach the pole of an electro-magnet a current of electricity is induced in the coils of the latter, and that when it is made to recede a current of opposite polarity to the first appears upon the wire. When, therefore, a permanent magnet is caused to vibrate in front of the pole of an electro-magnet an undulatory current of electricity is induced in the coils of the electro-magnet, the undulations of which correspond, in rapidity of succession, to the vibrations of the magnet, in polarity to the direction of its motion, and in intensity to the amplitude of its vibration.

That the difference between an undulatory and an intermittent current may be more clearly understood, I shall describe the condition of the electrical current when the attempt is made to transmit two musical notes simultaneously—first upon the one plan and then upon the other. Let the interval between the two sounds be a major third; then their rates of vibration are in the ratio of 4 to 5. Now, when the intermittent current is used, the circuit is made and broken four times by one transmitting instrument, in the same time that five makes and breaks are caused by the other. A and B, Figs. 1, 2, and 3, represent the intermittent currents produced, four impulses of B being made in the same time as five impulses of A; *c c c*, etc., show where and for how long time the circuit is made, and *d d d*, etc., indicate the duration of the breaks of the circuit. The line A and B shows the total effect upon the current when the transmitting instruments for A and B are caused simultaneously to make and break the same circuit. The resultant effect depends very much upon the duration of the make

## Statement of the case.

relatively to the break. In Fig. 1 the ratio is as 1 to 4; in Fig. 2, as 1 to 2; and in Fig. 3 the makes and breaks are of equal duration. The combined effect, A and B, Fig. 3, is very nearly equivalent to a continuous current.

When many transmitting instruments of different rates of vibration are simultaneously making and breaking the same circuit, the current upon the main line becomes, for all practical purposes, continuous.

Next, consider the effect when an undulatory current is employed. Electrical undulations, induced by the vibration of a body capable of inductive action, can be represented graphically, without error, by the same sinusoidal curve which expresses the vibration of the inducing body itself, and the effect of its vibration upon the air; for, as above stated, the rate of oscillation in the electrical current corresponds to the rate of vibration of the including body—that is, to the pitch of the sound produced. The intensity of the current varies with the amplitude of the vibration—that is, with the loudness of the sound; and the polarity of the current corresponds to the direction of the vibrating body—that is, to the condensations and rarefactions of air produced by the vibration. Hence, the sinusoidal curve A or B, Fig. 4, represents, graphically, the electrical undulations induced in a circuit by the vibration of a body capable of inductive action.

The horizontal line *a d e f*, etc., represents the zero of current. The elevations *b b b*, etc., indicate impulses of positive electricity. The depressions *c c c*, etc., show impulses of negative electricity. The vertical distance *b d* or *c f* of any portion of the curve from the zero-line expresses the intensity of the positive or negative impulse at the part observed, and the horizontal distance *a a* indicates the duration of the electrical oscillation. The vibrations represented by the sinusoidal curves B and A, Fig. 4, are in the ratio aforesaid, of 4 to 5—that is, four oscillations of B are made in the same time as five oscillations of A.

## Statement of the case.

The combined effect of A and B, when induced simultaneously on the same circuit, is expressed by the curve  $A + B$ , Fig. 4, which is the algebraical sum of the sinusoidal curves A and B. This curve  $A + B$  also indicates the actual motion of the air when the two musical notes considered are sounded simultaneously. Thus, when electrical undulations of different rates are simultaneously induced in the same circuit, an effect is produced exactly analogous to that occasioned in the air by the vibration of the inducing bodies. Hence, the co-existence upon a telegraphic circuit of electrical vibrations of different pitch is manifested not by the obliteration of the vibratory character of the current, but by peculiarities in the shapes of the electrical undulations, or, in other words, by peculiarities in the shapes of the curves which represent those undulations.

There are many ways of producing undulatory currents of electricity, dependent for effect upon the vibrations or motions of bodies capable of inductive action. A few of the methods that may be employed I shall here specify. When a wire, through which a continuous current of electricity is passing, is caused to vibrate in the neighborhood of another wire, an undulatory current of electricity is induced in the latter. When a cylinder, upon which are arranged bar-magnets, is made to rotate in front of the pole of an electro-magnet, an undulatory current of electricity is induced in the coils of the electro-magnet.

Undulations are caused in a continuous voltaic current by the vibration or motion of bodies capable of inductive action; or by the vibration of the conducting wire itself, in the neighborhood of such bodies. Electrical undulations may also be caused by alternately increasing and diminishing the resistance of the circuit, or by alternately increasing and diminishing the power of the battery. The internal resistance of a battery is diminished by bringing the voltaic elements nearer together, and increased by placing them farther apart. The reciprocal vibration of the elements of a battery, there-

## Statement of the case.

fore, occasions an undulatory action in the voltaic current. The external resistance may also be varied. For instance, let mercury or some other liquid form part of a voltaic circuit, then the more deeply the conducting wire is immersed in the mercury or other liquid, the less resistance does the liquid offer to the passage of the current. Hence, the vibration of the conducting wire in mercury or other liquid included in the circuit occasions undulations in the current. The vertical vibrations of the elements of a battery in the liquid in which they are immersed, produces an undulatory action in the current by alternately increasing and diminishing the power of the battery.

In illustration of the method of creating electrical undulations, I shall show and describe one form of apparatus for producing the effect. I prefer to employ for this purpose an electro-magnet, *A*, Fig. 5, having a coil upon only one of its legs, *b*. A steel-spring armature, *c*, is firmly clamped by one extremity to the uncovered leg *d* of the magnet, and its free end is allowed to project above the pole of the covered leg. The armature *c* can be set in vibration in a variety of ways, one of which is by wind, and, in vibrating, it produces a musical note of a certain definite pitch.

When the instrument *A* is placed in a voltaic circuit, *g b e f g*, the armature *c* becomes magnetic, and the polarity of its free end is opposed to that of the magnet underneath. So long as the armature *c* remains at rest, no effect is produced upon the voltaic current, but the moment it is set in vibration to produce its musical note a powerful inductive action takes place, and electrical undulations traverse the circuit *g b e f g*. The vibratory current passing through the coil of the electro-magnet *f* causes vibration in its armature *h* when the armature *c h* of the two instruments *A I* are normally in unison with one another; but the armature *h* is unaffected by the passage of the undulatory current when the pitches of the two instruments are different.

A number of instruments may be placed upon a tele-

## Statement of the case.

graphic circuit, as in Fig. 6. When the armature of any one of the instruments is set in vibration all the other instruments upon the circuit which are in unison with it respond, but those which have normally a different rate of vibration remain silent. Thus, if A, Fig. 6, is set in vibration, the armatures of A<sup>1</sup> and A<sup>2</sup> will vibrate also, but all the others on the circuit will remain still. So if B<sup>1</sup> is caused to emit its musical note the instruments B B<sup>2</sup> respond. They continue sounding so long as the mechanical vibration of B<sup>1</sup> is continued, but become silent with the cessation of its motion. The duration of the sound may be used to indicate the dot or dash of the Morse alphabet, and thus a telegraphic dispatch may be indicated by alternately interrupting and renewing the sound. When two or more instruments of different pitch are simultaneously caused to vibrate, all the instruments of corresponding pitches upon the circuit are set in vibration, each responding to that one only of the transmitting instruments with which it is in unison. Thus the signals of A, Fig. 6, are repeated by A<sup>1</sup> and A<sup>2</sup>, but by no other instrument upon the circuit; the signals of B<sup>2</sup> by B and B<sup>1</sup>; and the signals of C<sup>1</sup> by C and C<sup>2</sup>,—whether A, B<sup>2</sup>, and C<sup>1</sup> are successively or simultaneously caused to vibrate. Hence, by these instruments two or more telegraphic signals or messages may be sent simultaneously over the same circuit without interfering with one another.

I desire here to remark that there are many other uses to which these instruments may be put, such as the simultaneous transmission in musical notes, differing in loudness as well as in pitch, and the telegraphic transmission of noises or sounds of any kind.

When the armature *c*, Fig. 5, is set in vibration the armature *h* responds not only in pitch but in loudness. Thus, when *c* vibrates with little amplitude, a very soft musical note proceeds from *h*; and when *c* vibrates forcibly the amplitude of the vibration of *h* is considerably increased, and the

## Statement of the case.

resulting sound becomes louder. So, if A and B, Fig. 6, are sounded simultaneously (A loudly and B softly), the instrument A<sup>1</sup> and A<sup>2</sup> repeat loudly the signals of A, and B<sup>1</sup> B<sup>2</sup> repeat softly those of B.

One of the ways in which the armature *c*, Fig. 5, may be set in vibration has been stated above to be by wind. Another mode is shown in Fig. 7, whereby motion can be imparted to the armature by the human voice or by means of a musical instrument.

The armature *c*, Fig. 7, is fastened loosely by one extremity to the uncovered leg *d* of the electro-magnet *b*, and its other extremity is attached to the centre of a stretched membrane, *a*. A cone, A, is used to converge sound-vibrations upon the membrane. When a sound is uttered in the cone the membrane *a* is set in vibration, the armature *c* is forced to partake of the motion, and thus electrical undulations are created upon the circuit E *b e f g*. These undulations are similar in form to the air vibrations caused by the sound—that is, they are represented graphically by similar curves. The undulatory current passing through the electro-magnet *f* influences its armature *h* to copy the motion of the armature *c*. A similar sound to that uttered into A is then heard to proceed from L.

In this specification the three words “oscillation,” “vibration,” and “undulation,” are used synonymously, and in contradistinction to the terms “intermittent” and “pulsatory.” By the term “body capable of inductive action,” I mean a body which, when in motion, produces dynamical electricity. I include in the category of bodies capable of inductive action brass, copper, and other metals, as well as iron and steel.

Having described my invention, what I claim and desire to secure by letters patent, is as follows:

1. A system of telegraphy in which the receiver is set in vibration by the employment of undulatory currents of electricity, substantially as set forth.

## Statement of the case.

2. The combination, substantially as set forth, of a permanent magnet or other body capable of inductive action, with a closed circuit, so that the vibration of the one shall occasion electrical undulations in the other, or in itself; and this I claim, whether the permanent magnet be set in vibration in the neighborhood of the conducting wire forming the circuit, or whether the conducting wire be set in vibration in the neighborhood of the permanent magnet, or whether the conducting wire and the permanent magnet both simultaneously be set in vibration in each other's neighborhood.

3. The method of producing undulations in a continuous voltaic current by the vibration or motion of bodies capable of inductive action, or by the vibration or motion of the conducting wire itself, in the neighborhood of such bodies, as set forth.

4. The method of producing undulations in a continuous voltaic circuit by gradually increasing and diminishing the resistance of the circuit, or by gradually increasing and diminishing the power of the battery, as set forth.

5. The method of, and apparatus for, transmitting vocal or other sounds telegraphically, as herein described, by causing electrical undulations, similar in form to the vibrations of the air accompanying the said vocal or other sounds, substantially as set forth.

In testimony whereof I have hereunto signed my name this 20th day of January, A. D. 1876.

ALEX. GRAHAM BELL.

Witnesses :

THOMAS E. BARRY,  
P. D. RICHARDS.



## Statement of the case.

ALEXANDER GRAHAM BELL, OF BOSTON,  
MASSACHUSETTS.

## IMPROVEMENT IN ELECTRIC TELEGRAPHY.

Specification forming part of Letters Patent, No. **186,787**,  
dated January 30, 1877; application filed January 15, 1877.

*To all whom it may concern:*

Be it known that I, ALEXANDER GRAHAM BELL, of Boston, Massachusetts, have invented certain new and useful Improvements in Electric Telephony, of which the following is a specification:

In letters patent granted to me on the 6th day of April, 1875, No. 161,739, and in an application for letters patent of the United States now pending, I have described a method of, and apparatus for, producing musical tones by the action of a rapidly-interrupted electrical current, whereby a number of telegraphic signals can be sent simultaneously along a single circuit.

In another application for letters patent now pending in the United States Patent Office, I have described a method of, and apparatus for, inducing an intermittent current of electricity upon a line-wire, whereby musical tones can be produced and a number of telegraphic signals be sent simultaneously over the same circuit, in either or in both directions; and in letters patent granted to me March 7, 1876, No. 174,465, I have shown and described a method of, and apparatus for, producing musical tones by the action of undulatory currents of electricity, whereby a number of telegraphic signals can be sent simultaneously over the same circuit, in either or in both directions, and a single battery be used for the whole circuit.

In the applications and patents above referred to, signals are transmitted simultaneously along a single wire by the employment of transmitting instruments, each of which

## Statement of the case.

occasions a succession of electrical impulses differing in rate from the others, and are received without confusion by means of receiving instruments, each tuned to a pitch at which it will be put in vibration to produce its fundamental note by one only of the transmitting instruments. A separate instrument is therefore employed for every pitch, each instrument being capable of transmitting or receiving but a single note, and thus as many separate instruments are required as there are messages or musical notes to be transmitted.

My invention has for its object, first, the transmission simultaneously of two or more musical notes or telegraphic signals along a single wire in either or both directions, and with a single battery for the whole circuit, without the use of as many instruments as there are musical notes or telegraphic signals to be transmitted; second, the electrical transmission by the same means of articulate speech and sound of every kind, whether musical or not; third, the electrical transmission of musical tones, articulate speech, or sounds of every kind, without the necessity of using a voltaic battery.

In my patent No. 174,465, dated March 7, 1876, I have shown as one form of transmitting instrument a stretched membrane, to which the armature of an electro-magnet is attached, whereby motion can be imparted to the armature by the human voice, or by means of a musical instrument, or by sounds produced in any way.

In accordance with my present invention I substitute for the membrane and armature shown in the transmitting and receiving instruments alluded to above, a plate of iron or steel capable of being thrown into vibration by sounds made in its neighborhood.

The nature of my invention and the manner in which the same is or may be carried into effect, will be understood by reference to the accompanying drawings, in which—

Figure 1 is a perspective view of one form of my electric telephone. Fig. 2 is a vertical section of the same, and Fig.

A. G. BELL.  
ELECTRIC TELEGRAPHY.

No. 186,787.

Patented Jan. 30, 1877.

Fig. 1.

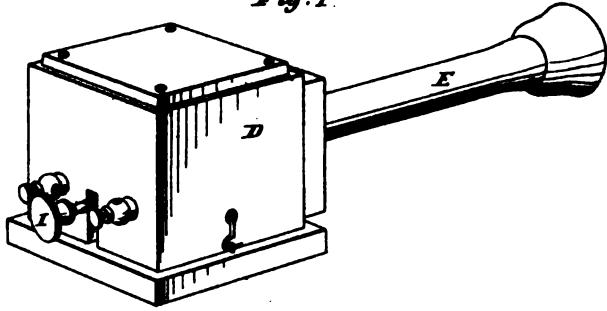

Fig. 2.

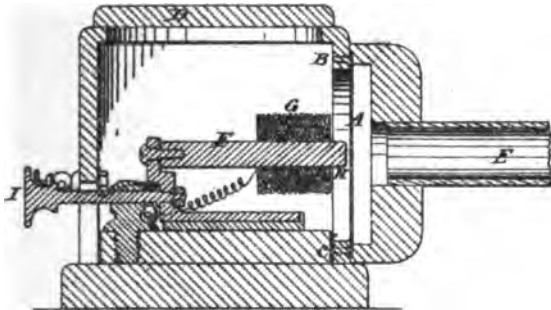
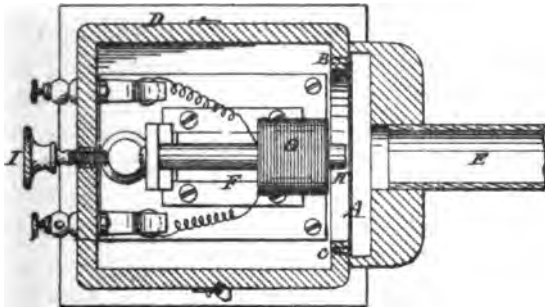

Fig. 3.



Attest  
*A. S. Hall*  
Clerk

Inventor:  
*Alexander Graham Bell*



A. G. BELL.  
ELECTRIC TELEGRAPHY.

No. 186,787.

Patented Jan. 30, 1877.

Fig. 4.

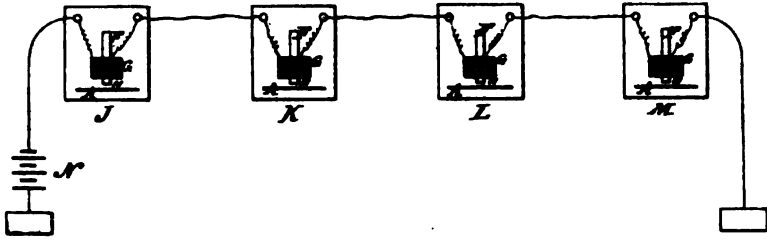

Fig. 5.

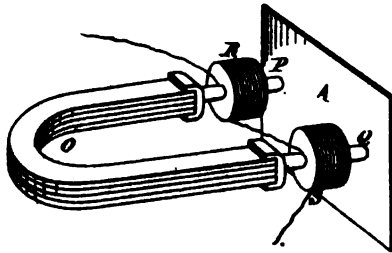
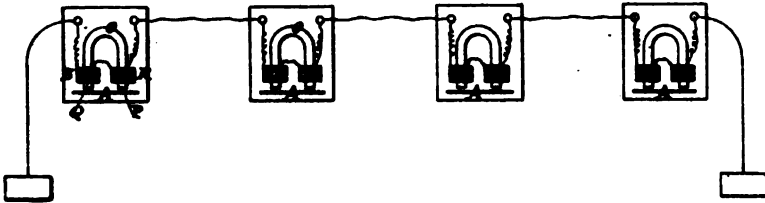
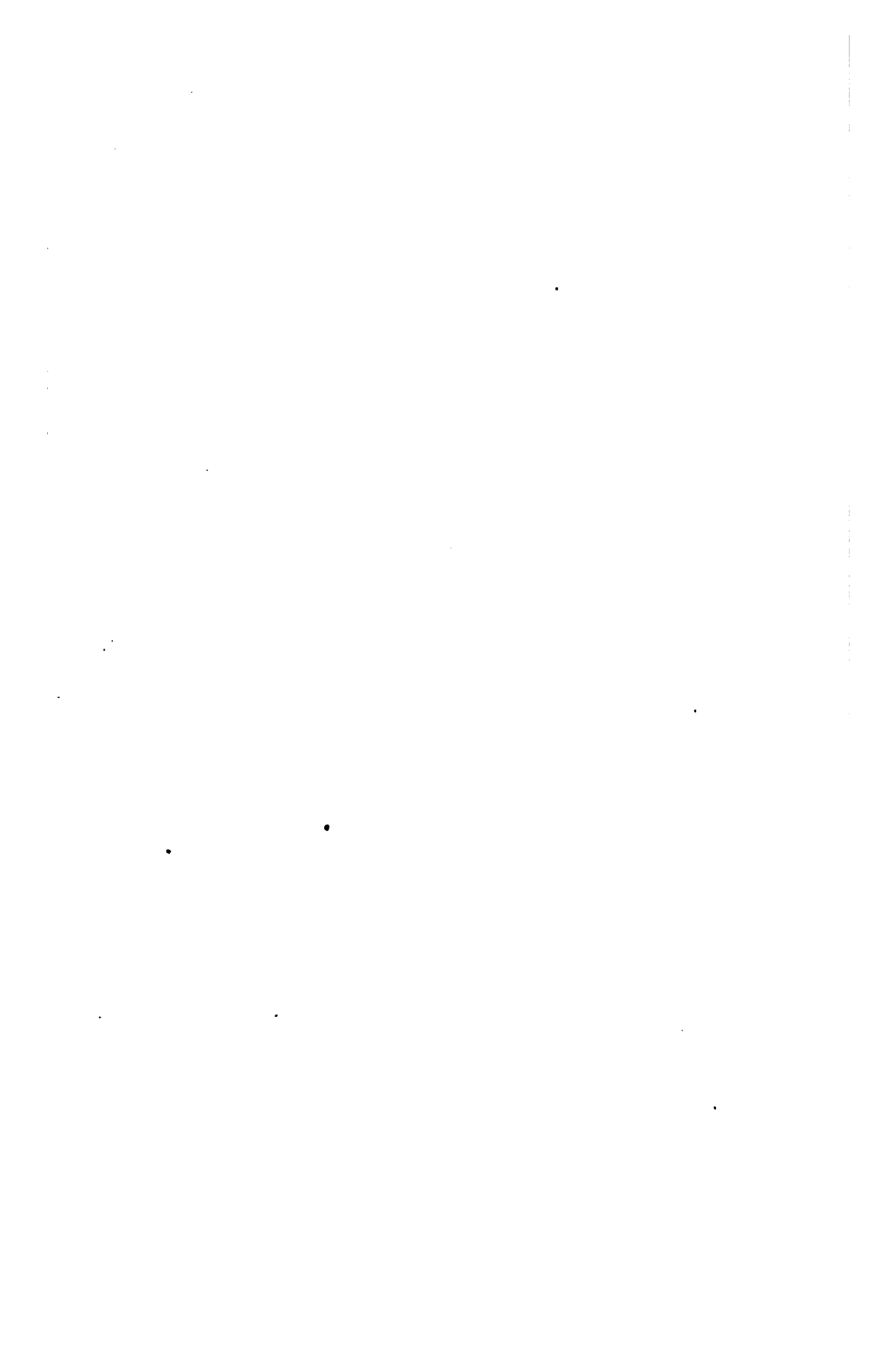

Fig. 6.



Attest:  
*A. P. Peck*  
Clerk

Inventor:  
*Alexander Graham Bell*



## Statement of the case.

3 is a plan view of the apparatus. Fig. 4 is a diagram illustrating the arrangement upon circuit.

Similar letters in the drawings represent corresponding portions of the apparatus.

A in said drawings represents a plate of iron or steel, which is fastened at B and C to the cover or sounding box D. E represents a speaking tube, by which sounds may be conveyed to or from the plate A. F is a bar of soft iron. G is a coil of insulated copper wire, placed around the extremity of end H of the bar F. I is an adjusting screw, whereby the distance of the end H from the plate A may be regulated.

The electric telephones J, K, L, and M are placed at different stations upon a line, and are arranged upon circuit with a battery, N, as shown in diagram, Fig. 4.

I have shown the apparatus in one of its simplest forms, it being well understood that the same may be varied in arrangement, combination, general construction, and form, as well as material of which the several parts are composed.

The operation and use of this instrument are as follows:

I would premise by saying that this instrument is and may be used both as a transmitter and as a receiver—that is to say, the sender of the message will use an instrument in every particular identical in construction and operation with that employed by the receiver, so that the same instrument can be used alternately as a receiver and a transmitter.

In order to transmit a telegraphic message by means of these instruments, it is only necessary for the operator at a telephone (say J) to make a musical sound in any way in the neighborhood of the plate A—for convenience of operation, through the speaking tube E—and to let the duration of the sound signify the dot or dash of the Morse alphabet, and for the operator who receives his message (say at M) to listen to his telephone, preferably through the speaking tube E. When two or more musical signals are being transmitted over the same circuit all the telephones reproduce the signals for all the messages; but as the signals for each message

## Statement of the case.

differ in pitch from those for the other messages, it is easy for an operator to fix his attention upon one message and ignore the other.

When a large number of dispatches are being simultaneously transmitted it will be advisable for the operator to listen to his telephone through a resonator, which will reinforce to his ear the signals which he desires to observe. In this way he is enabled to direct his attention to the signals for any given message, without being distracted or disturbed by the signals for any other message that may be passing over the line at the time.

The musical signals, if preferred, can be automatically received by means of a resonator, one end of which is closed by a membrane, which vibrates only when the note with which the resonator is in unison is emitted by the receiving telephone. The vibrations of the membrane may be made to operate a circuit-breaker, which will actuate a Morse sounder or a telegraphic recording or registering apparatus.

One form of vibratory circuit-breaker which may be used for this purpose I have described in letters patent No. 178,399, June 6, 1876. Hence, by this plan the simultaneous transmission of a number of telegraphic messages over a single circuit in the same or in both directions, with a single main battery for the whole circuit and a single telephone at each station, is rendered practicable. This is of great advantage in this, that for the conveyance of several messages, or signals, or sounds over a single wire simultaneously, it is no longer necessary to have separate instruments, correspondingly tuned for each given sound, which plan requires nice adjustment of the corresponding instruments, while the present improvement admits of a single instrument at each station, or if for convenience several are employed, they all are alike in construction, and need not be adjusted or tuned to particular pitches.

Whatever sound is made in the neighborhood of any telephone—say at J, Fig. 4—is echoed in fac-simile by the tele-



## Statement of the case.

phones of all the other stations upon the circuit; hence, this plan is also adapted for the use of transmitting intelligibly the exact sounds of articulate speech. To convey an articulate message it is only necessary for an operator to speak in the neighborhood of his telephone, preferably through the tube E, and for another operator at a distant station upon the same circuit to listen to the telephone at that station. If two persons speak simultaneously in the neighborhood of the same or different telephones, the utterances of the two speakers are reproduced simultaneously by all the other telephones on the same circuit; hence, by this plan a number of vocal messages may be transmitted simultaneously on the same circuit, in either or both directions. All the effects noted above may be produced by the same instruments without a battery by rendering the central bar F H permanently magnetic. Another form of telephone for use without a battery is shown in Fig. 5, in which O is a compound permanent magnet, to the poles of which are affixed poll-pieces of soft-iron, P Q, surrounded by helices of insulated wire, R S.

Fig. 6 illustrates the arrangement upon circuits of similar instruments to that shown in Fig. 5.

In lieu of the plate A in above figures, iron or steel reeds of definite pitch may be placed in front of the electro-magnet O, and, in connection with a series of such instruments of different pitches, an arrangement upon circuit may be employed similar to that shown in my patent No. 174,465, and illustrated in Fig. 6 of Sheet 2 in said patent. The battery, of course, may be omitted.

This invention is not limited to the use of iron or steel, but includes within its scope any material capable of inductive action.

The essential feature of the invention consists in the armature of the receiving instrument being vibrated by the varying attraction of the electro-magnet, so as to vibrate the air in the vicinity thereof, in the same manner as the air is vibrated at the other end by the production of the sound. It

## Statement of the case.

is, therefore, by no means necessary or essential that the transmitting instrument should be of the same construction as the receiving instrument. Any instrument receiving and transmitting the impression of agitated air may be used as the transmitter, although, for convenience and for reciprocal communication, I prefer to use like instruments at either end of an electrical wire. I have heretofore described and exhibited such other means of transmitting sound, as will be seen by reference to the proceedings of the American Academy of Arts and Sciences, Volume XII.

For convenience, I prefer to apply to each instrument a call-bell. This may be arranged so as to ring, first, when the main circuit is open; second, when the bar F comes into contact with the plate A. The first is done to call attention; the second indicates when it is necessary to readjust the magnet, for it is important that the distance of the magnet from the plate should be as little as possible; without, however, being in contact. I have also found that the electrical undulations produced upon the main line by the vibration of the plate A are intensified by placing the coil G at the end of the bar F nearest the plate A, and not extend it beyond the middle, or thereabout.

Having thus described my invention, what I claim and desire to secure by letters patent, is:

1. The union upon, and by means of, an electric circuit of two or more instruments, constructed for operation substantially as herein shown and described, so that, if motion of any kind or form be produced in any way in the armature of any one of the said instruments, the armatures of all the other instruments upon the same circuit will be moved in like manner and form, and if such motion be produced in the former by sound, like sound will be produced by the motion of the latter.

2. In a system of electric telegraphy or telephony, consisting of transmitting and receiving instruments united upon an electric circuit, the production, in the armature of each

## Statement of the case.

receiving instrument, of any given motion by subjecting said armature to an attraction varying in intensity, however such variation may be produced in the magnet; and hence I claim the production of any given sound or sounds from the armature of the receiving instrument by subjecting said armature to an attraction varying in intensity, in such manner as to throw the armature into that form of vibration that characterizes the given sound or sounds.

3. The combination, with an electro-magnet, of a plate of iron or steel, or other material capable of inductive action, which can be thrown into vibration by the movement of surrounding air or by the attraction of a magnet.

4. In combination with a plate and electro-magnet, as before claimed, the means herein described, or their mechanical equivalents, of adjusting the relative position of the two, so that, without touching, they may be set as closely together as possible.

5. The formation in an electric telephone, such as herein shown and described, of a magnet with a coil upon the end or ends of the magnet nearest the plate.

6. The combination, with an electric telephone such as described, of a sounding-box, substantially as herein shown and set forth.

7. In combination with an electric telephone as herein described, the employment of a speaking or hearing tube for conveying sounds to or from the telephone, substantially as set forth.

8. In a system of electric telephony, the combination of a permanent magnet with a plate of iron or steel, or other material capable of inductive action, with coils upon the end or ends of said magnet nearest the plate, substantially as set forth.

In testimony whereof I have hereunto signed my name this 13th day of January, A. D. 1877.

A. GRAHAM BELL.

Witnesses:

HENRY R. ELLIOTT,

EWELL A. DICK.

## Statement of the case.

The above-mentioned letters patent were both duly assigned July, 1877, by Alexander Graham Bell to Gardiner C. Hubbard, trustee, and were further duly assigned July 20, 1878, by said Hubbard, trustee, to the Bell Telephone Company, a corporation created by the laws of Massachusetts, located at Boston; and were further duly assigned by the Bell Telephone Company to the American Bell Telephone Company, a corporation created by the laws of said State, the complainant in these actions.

The American Bell Telephone Company was incorporated by a law of Massachusetts, chapter 117, March 19, 1880, "for the purpose of manufacturing, owning, selling, using, and licensing others to use electric speaking telephones," etc., with authority to "become interested with other corporations" for like purposes; the certificate of the president, treasurer, and directors of said corporation, duly approved by the Commissioner of Corporations, was recorded in the office of the Secretary of State of Massachusetts; and the Secretary of the Commonwealth issued his certificate, in the form required by section 11, of chapter 224, of the Acts of 1870, that the persons named, their associates and successors, were legally organized and established and made an existing corporation, under the name of the American Bell Telephone Company. This section made such certificate conclusive evidence of the existence of the corporation organized under that chapter

## THE DOLBEAR CASE.

This case first came up for hearing on a motion for a preliminary injunction, which was elaborately argued before Mr. Justice GRAY and Judge LOWELL.

The question was, whether, assuming Mr. Bell to have been the inventor of the speaking telephone, his patent reached the somewhat peculiar apparatus of the defendant. The motion was argued in May, 1882, and January 24, 1883, the opinion, written by Mr. Justice GRAY, was filed. The Court sustained the plaintiff's claim and granted the injunc-

## Statement of the case.

tion. The case then went to final hearing, and the defendants again contended that Mr. Bell was not the first inventor of the speaking telephone, but that it was invented and described in printed publications by Philip Reis, ten years or more before Mr. Bell's time; and, as a consequence, that Mr. Bell had merely invented a special form of speaking telephone, which they said was not used by the defendants. It was heard at final hearing before His Honor Judge LOWELL, June 30, 1883. It was argued for the defendants by Messrs. Causten Browne, and J. E. Maynardier, and on August 25, 1883, Judge LOWELL decided that the patent was valid, and was of the scope contended for by the complainants, that the defendants infringed it, and that Reis had not invented a speaking telephone.

This case is reported *sub nom.* American Bell Telephone Co. v. Dolbear. The opinion delivered by Mr. Justice GRAY on granting the injunction *pendente lite* is in 15 Fed. Rep. 438; that of Judge LOWELL on final hearing is in 17 Fed. Rep. 604.

The bill in this case charges infringement of letters patent No. 174,465, dated March 7, 1876, granted to Alexander Graham Bell. The answer denies the validity of the patent, and also denies infringement. The final decree was that the defendants have infringed the 5th claim of the Bell patent of 1876.

The errors assigned by the appellants in this case are:

"1. That the Court below construed the method of the 5th claim to consist in causing electrical undulations similar in form to the sound waves.

"2. That the Court below held the 5th claim so construed to be for a patentable subject.

"3. That the Court below decided that the method and apparatus used by defendants infringed the 5th claim."

The appellants in this case contend:

"1. That the 5th claim, as construed by the Circuit Court

## Statement of the case.

of the District of Massachusetts, is not for an art, machine, manufacture or composition of matter, and is therefore void.

“ 2. That the 5th claim, as construed by the Circuit Court of the District of Massachusetts, is not for any invention or discovery, and is therefore void.

“ 3. That causing electrical undulations similar in form to the vibrations of air accompanying vocal or other sounds, is not a method or an art, but simply an object to be accomplished.

“ 4. That the only invention or discovery possible in regard to causing such electrical undulations, was as to some method of, or apparatus for, causing them, and for using them.

“ 5. That transmitting articulate sounds by undulatory vibrations of electricity is not an art or a process, and is not the subject of either invention or discovery, but is merely a result to be attained, or an object to be accomplished; and that the only invention or discovery possible in relation to such result or object is of some method of, or apparatus for, attaining such result or accomplishing such object.

“ 6. That neither the method nor the apparatus patented by said letters patent of 1876 has ever been used by the appellants, nor has any method or apparatus substantially like said patented method or apparatus ever been used by the appellants.”

The appellees claim that Dolbear's apparatus differs from those of the other defendants only by the employment of a *condenser-receiver* instead of a *magneto-receiver*; that Dolbear and all his experts employ Bell's method and in substance his apparatus; that they necessarily produce the electrical undulations of the form described and claimed in Bell's patent; that they employ the part of Bell's invention which is the most novel and characteristic, and this is what makes their instrument to be a speaking telephone; that they copy Mr. Bell in the great step of employing electrical undulations similar in form to the sound-waves; that the gist of Bell's invention patented lies in the employment of electrical undu-

## Statement of the case.

lations of the new form, which implies their creation by the voice, their conveyance and their reconversion into sound-waves; that Dolbear employs them and cannot speak without them; that his precise mode of creating them is the legal equivalent of Bell's; that his form of conductor was a well-known equivalent for Bell's precise form; that the only difference is that when the peculiar measured quantities reach the receiving station, Bell lets them announce themselves by virtue of one well-known property which attracts the announcing plate; and Dolbear lets them announce themselves by virtue of another well-known property which attracts the announcing plate.

The following are the drawings and specifications of the Dolbear patent:

AMOS E. DOLBEAR, OF SOMERVILLE,  
MASSACHUSETTS.

## APPARATUS FOR TRANSMITTING SOUND BY ELECTRICITY.

Specification forming part of Letters Patent, No. **239,742**, dated April 5, 1881; application filed October 11, 1880. (Model.)

*To all whom it may concern:*

Be it known that I, AMOS E. DOLBEAR, of Somerville, in the county of Middlesex, and State of Massachusetts, have invented a new Apparatus for Transmitting Sound by Electricity, of which the following is a full, clear, concise, and exact description, reference being had to the accompanying drawings, making a part hereof, in which—

Figs. 1 and 2 are two views of the best form of apparatus for practicing my invention. Fig. 3 is a cross-section, enlarged, of the receiver shown in Fig. 1. Fig. 4 is a plan

## Statement of the case.

of one of the plates. Fig. 5 is a diagram illustrating the system.

My invention consists, mainly, in a new mode of transmitting articulate and other sounds by an open circuit.

It also consists in new apparatus for this purpose.

My receiver is based upon the well-known principle that one terminal of an open circuit will attract the other terminal when both are charged; and my invention consists, mainly, in the arrangement of the enlarged terminal of the secondary coil of an induction-coil, so that it will be vibrated toward and from the other terminal by variations in the electric state of the coil, and in such a manner as to reproduce sound-vibrations of all qualities, including articulate speech, when the primary circuit of the induction-coil contains a suitable transmitter.

Another feature of my invention relates to the system of connecting two or more receivers and two or more transmitters for practical use; and it consists in the combination of two induction-coils, two receivers, and two transmitters in a novel manner, fully described below.

The best form of my receiver is that shown in elevation in Fig. 1, and in cross-section in Fig. 3.

In Fig. 3 the case of the receiver A is shown as made up of three pieces—a back piece, *r*, an ear-piece, *s*, and an annular connecting piece, *t*, for connecting the pieces *r* and *s* together.

*a b* are thin elastic plates, preferably of iron, forming terminals of the secondary coil of an induction-coil. These plates are securely fastened about the edges and brought very near to each other, but not in contact, a thin annulus, *d*, lying between them. This is best effected by forming a thin flange, *d*, on the interior of the connecting piece, *t*, and placing the terminals *a b* on opposite sides of this flange. The ear-piece, *s*, of the case holds the terminal, *a*, in place, with the proper tension around the edge to insure mass vibrations of that terminal. The terminal, *b*, is held in place by the back



A. E. DOLBEAR.

Apparatus for Transmitting Sound by Electricity  
No. 239,742. Patented April 5, 1881.

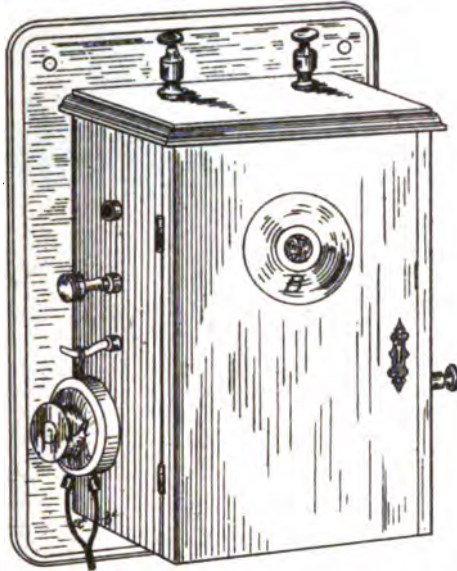

Fig. 1.

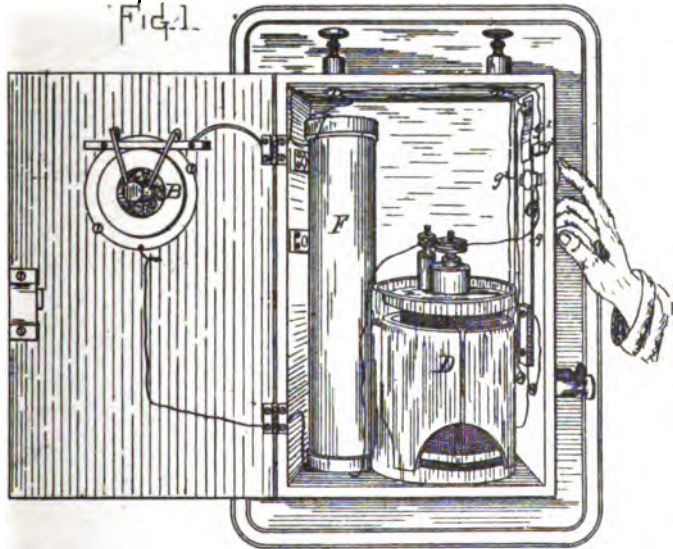

Fig. 2.

Weylitt  
John R. Brown

Amos C. Dolbear  
by J. S. Maynard  
his atty.



## Statement of the case.

piece,  $r$ , of the case. Each of the plates  $a$  and  $b$  is formed with a small tongue,  $a^2$  (see Fig. 4), with which the binding screws are connected, as shown.

As the section-plane in Fig. 3 will pass through but one of the binding screws (that for the wire  $a'$ ), the receiver is shown broken away at  $x$ , in order to show the binding screw for the wire  $b'$ . Both are shown in Fig. 1. One of the binding screws connects with plate  $a$ , the other with plate  $b$ . By the use of the tongues an even pressure around the whole edge of the plate is possible.

The adjustment of the instrument is effected by the screw  $A'$ ; and this screw, by contact upon the back plate,  $b$ , prevents any vibrations of that plate which interfere with the proper vibrations of the front plate,  $a$ .

My system requires electricity of a very high electro-motive force, and this is best obtained by means of a secondary coil with a high resistance, the best results having been obtained from four or five thousand ohms of No. 36 copper wire.

Transmitters, such as are in common use, will answer with my receiver; but the best form of transmitter is that shown in the drawings (which is not here described, as it forms the subject of an application for a patent filed by me May 31, 1880).

The main advantages of my new system over all others known to me are, that it is not appreciably affected by ordinary induced currents on the line; it has no magnet to deteriorate; the adjustment is more simple and is not affected by barometric and hygrometric variations, and it lacks the fine-wire helix of the common receiver, which is very liable to get out of repair. It is very efficient also on very long lines.

The best system for the practical use of my invention is illustrated in the diagram, Fig. 5, and the best form of apparatus is that shown in Figs. 1 and 2. In these figures,  $A$  represents the receivers,  $B$  the transmitters,  $D$  the batteries,  $F$  the induction-coils, and  $G$  switches.

## Statement of the case.

The transmitter B and battery D are in the circuit with the primary coil of the induction-coil F, and this circuit is completed, when the transmitter is to be used, by throwing over the member  $g$  of switch G until it makes contact with the member  $g'$ , thereby completing the battery-circuit through the transmitter and primary coil. The electricity induced in the secondary coil affects the plates in the distant receiver by means of that branch of wire  $m'$  which extends from one end of the secondary coil to member  $g$  of switch G, members  $g$  and  $g^2$  of switch G, the line-wire  $l$ , which is a continuation of member  $g^2$  of switch G, wire  $l^2$ , which is a branch of line-wire  $l$ , receiver-wires  $a' b'$ , wire  $m^2$ , members  $g g^3$  of switch G, wire  $n^2$ , to earth, thus cutting out the receiver at the sending-station (on the left of the diagram) and the secondary coil on the right of the diagram.

When the sending-station is at the right of the diagram, the switch G at the right will be arranged as is the switch G at the left, and the receiver at the left is electrified by means of wire  $l'$ , receiver-wires  $a' b'$  (at the left of the diagram), wire  $m'$ , members  $g g^3$  of switch G (at the left of the diagram), wire  $n'$ , to earth.

The switch G is composed of two springs,  $g g^2$ , and two stops,  $g' g^3$ , arranged as shown, so that when spring  $g$  is brought in contact with stop  $g'$  it will also be in contact with spring  $g^2$ , and when spring  $g$  is in contact with stop  $g^3$  it will be out of contact with both spring  $g^2$  and stop  $g'$ . One end of the secondary coil on the left of the diagram is connected with spring  $g$  on the left of diagram by means of one branch of wire  $m'$ , and with receiver-wire  $b'$  on the left of diagram by means of the other branch of wire  $m'$ , and one end of the secondary coil on the right of the diagram is connected with spring  $g$  on the right of diagram by means of one branch of wire  $m^2$ , and with receiver-wire  $b'$  on the right of the diagram by means of the other branch of wire  $m^2$ .

I am aware of the apparatus mentioned as used by Dr. Wright in "Ferguson's Electricity," published by William

## Statement of the case.

and Robert Chambers, of London and Edinburgh, in 1867, pages 258 and 259, in which two sheets of paper silvered on one side were placed back to back and connected with the two ends of an induction-coil, the primary circuit of which contained a Reis transmitter; and I disclaim that apparatus. My receiver differs from it in that the sounds transmitted are reproduced by the mass vibrations of one of the terminals, while in the Wright receiving apparatus the sound produced was mainly, if not altogether, due to molecular motion, and not to mass vibrations. Moreover, Wright's sheets of silvered paper were so arranged that each would damp any mass vibrations of the other; and in his apparatus any slight mass vibrations, even if not wholly damped, would be necessarily so irregular as to be worthless as a means of reproducing sounds. The fact, also, that the mass vibrations of each sheet damped those of the other sheet would make all the mass vibrations worthless for this purpose.

I am also aware of English patents No. 4,934 of 1877, and No. 2,396 of 1878, and disclaim all therein shown.

What I claim as my invention is—

1. The receiver above described, consisting of the plates *a* *b*, mounted in case *r s t*, and separated by the annulus *d*, in combination with induction-coil *F*, substantially as described.

2. In combination, two induction-coils, the primary of each containing a battery *D*, and transmitter *B*, and the secondary circuits, each containing receiver *A*, by means of switches *G*, consisting of members *g g' g<sup>2</sup> g<sup>3</sup>*, whereby the receiver at the sending-station and coil at the receiving-station are switched out of the line, substantially as described.

AMOS E. DOLBEAR.

## Statement of the case.

AMOS E. DOLBEAR, OF SOMERVILLE,  
MASSACHUSETTS.

## MODE OF TRANSMITTING SOUND BY ELECTRICITY.

Specification forming part of Letters Patent, No. **240,578**,  
dated April 26, 1881; application filed February 24, 1881.  
(Model.)

*To all whom it may concern :*

Be it known that I, AMOS E. DOLBEAR, of Somerville, in the county of Middlesex and State of Massachusetts, have invented a new Mode of Transmitting Sounds by Electricity, of which the following is a full, clear, concise, and exact description, reference being had to the accompanying drawings, making a part hereof.

My invention consists, mainly, in a new mode of transmitting articulate and other sounds by an open circuit.

It also consists in new apparatus for this purpose.

My receiver is based upon the discovery that one terminal of an open circuit will attract and be attracted by a neighboring body when the terminal is charged.

Fig. 1 shows two modifications of my receiver, in section, connected in circuit with a transmitter and induction-coil. Fig. 2 shows another modification of my receiver.

Three forms of my receiver are shown in the drawings. In each the casing is formed of three pieces, *r* being the back-piece, *s* the ear-piece, and *t* the connecting-piece which connects *r* and *s* together. The plate *a* of receiver I is a thin elastic disc, preferably of iron, the vibrations of which reproduce the sound which causes the diaphragm of the transmitter *T* to vibrate, *T* representing a transmitter of suitable construction, the form preferred being that shown in my application for a patent filed May 31, 1880, the transmitter *T* and the battery *B* being in circuit with the primary coil, as will be clear without further description.

(Model.)

A. E. DOLBEAR.

Mode of Transmitting Sound by Electricity.

No. 240,578.

Patented April 26, 1881.

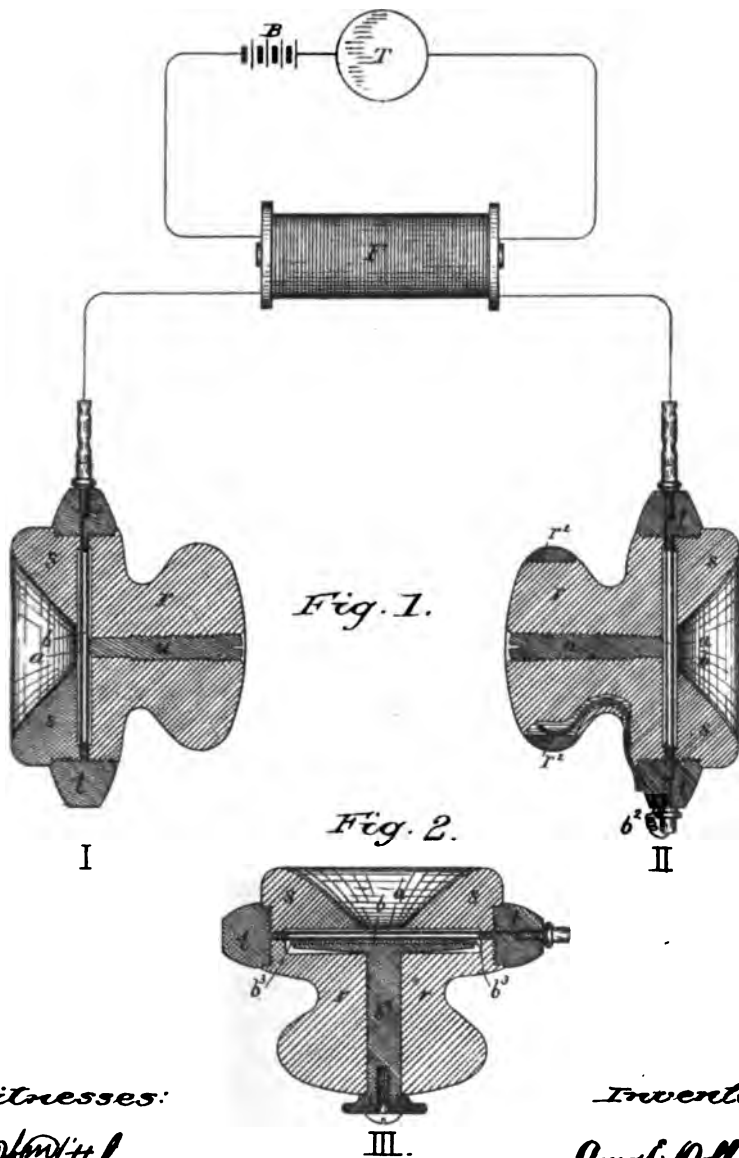

Witnesses:

*Wm. Hittel*  
*John Brown*

Inventor.

*Amos C. Dolbear*  
*J. S. Maynard*





## Statement of the case.

In receiver I the plate *a* is one terminal of the secondary coil F, and any change in the electrical state of coil F varies the potential of this plate *a* in receiver I and causes it to attract plate *b*, which is mounted close to, but not in contact with, plate *a*; but as plate *b* in receiver I is so mounted that it cannot vibrate, plate *a* will vibrate as its potential varies. In receiver I the plate *b* and back-piece *r* and adjusting screw *u* are all of metal.

It will be seen that neither the plate *b* nor back-piece *r* nor screw *u* of receiver I is connected to the coil F, but that only one terminal of coil F—viz., plate *a*—forms any part of the receiver I. The plate *b* may be made in one piece with back-piece *r*, but for purposes of adjustment is best made as shown.

The force of the attraction between the charged terminal *a* and any neighboring body is slight, unless the neighboring body be many times larger than the terminal, and itself capable of being readily electrified, and for this reason, when the neighboring body is a plate (as it is best made for purpose of adjustment), it should be electrically connected with a larger body. Consequently, the back-piece *r* of the case of receiver I is made of metal, and is in metallic contact with plate *b*. The neighboring body, which is attracted by plate *a* in receiver I (being, in fact, the plate *b*, piece *r* and screw *u*, which are all of metal and in metallic contact), acts as one body in this receiver I; but, as will be clear, the back-piece *r*, plate *b*, and screw *u* may be one single piece of metal, and some other provision be made for the necessary adjustment.

In receiver II the terminal *a* is mounted upon back-piece *r*, so that it cannot vibrate, and must, therefore, be insulated. Consequently, the back-piece *r* is made of hard rubber. The plate *b*, which is the neighboring body in receiver II, is connected by the wire *b*<sup>2</sup> with a metal band, *r*<sup>2</sup>, upon back-piece *r*, in order to increase the attractive force due to the electrification of a greater mass than plate *b*, and without interfering

## Statement of the case.

with the proper vibration of plate *b*, which, in receiver II, vibrates as the potential of terminal *a* varies.

It will be clear that either of the plates *b* may be grounded, and thereby increase the electrification of these plates; but it is not necessary to ground either of them, and the audibility of the sounds reproduced is practically as great when the back-piece of the receiver is held in the hand as when the plates *b* are both grounded; and it makes no difference whatever whether both be grounded or only one. In other words, receiver I will reproduce articulate and other sounds, even if back-piece *r* be of hard rubber or other non-conductor, and plate *b* be wholly disconnected from coil F, but the sounds reproduced are faint, although distinct and audible. The sounds will be louder if the piece *r* be of metal, as above described, or if the plate *b* or metallic piece *r* be grounded; but the difference is very slight, the sounds being practically as loud when the metal piece *r* is used as when the plate *b* is grounded. And so of receiver II, the sounds are distinct and audible when wire *b*<sup>1</sup> and metal band *r*<sup>2</sup> are omitted, but louder when metal band *r*<sup>2</sup> and wire *b*<sup>1</sup> are used, as shown, or when plate *b* of receiver II is grounded. Moreover, the reproduction of sound by receiver I does not depend at all upon the grounding of any part of receiver II, for receiver I will act with plate *b* of receiver II not grounded precisely as it does when plate *b* of receiver II is grounded, and receiver II will act when plate *b* of receiver I is not grounded precisely as it acts when that plate of receiver I is grounded.

In my application, filed October 31, 1880, I have described a receiver in which both the plates *a* and *b* are connected with the coil F, and I therefore disclaim in this application any receiver having both the plates connected with that coil, my present invention consisting in a receiver in which only one terminal of the coil is used, as above explained.

Instead of making plate *b* of metal, and connecting it metallically with back-piece *r* or band *r*<sup>2</sup>, it may be made of

## Statement of the case.

any non-conductor, and in this case the increased loudness is produced by electrifying plate *b* before it is put in place ; or, as shown in receiver III, where *b* is a rubber plate, and *b*<sup>3</sup> is a disc of felt fast to the hard-rubber support *b*<sup>4</sup>, which is turned by the thumb and finger to electrify rubber plate *b* by friction.

What I claim as my invention is :

In combination, a primary coil in circuit, with battery B and transmitter T, and a secondary coil, with its enlarged terminal *a* mounted in case *r s t*, and arranged near plate *b*, plate *b* being also mounted in case *r s t*, but not connected with the secondary coil, all substantially as described.

AMOS E. DOLBEAR.

Witnesses :

J. E. MAYNADIER,  
JOHN R. SNOW.

## THE MOLECULAR CASE.

On July 17, 1883, the Bell Company brought a suit in equity in the United States Circuit Court for the Southern District of New York against the Molecular Telephone Company and others. The bill charges the infringement of Bell's letters patent above stated. The answer denies the validity of the letters and the alleged infringement, and sets up several alleged prior inventors, but the chief stress was laid upon the work and publications of Philip Reis, either to destroy the Bell patent or to narrow it to a patent for a mere change of form. All the prior publications, set up in Spencer's case, and all the prior publications set up in Dolbear's case were also introduced in the Molecular case, and a few more added ; and substantially all the testimony taken in the Hopkins and Overland cases and in Spencer's case were introduced, and the same experts were recalled and further examined by the defendants. The case was argued before Judge WALLACE, in March and April, 1885.

On final hearing upon the pleadings and proofs, a decree

## Statement of the case.

was entered for the complainants upon the 5th claim of said letters patent No. 174,465 ; and the 6th, 7th and 8th claims of said letters patent No. 186,787 ; and the defendants appealed.

Upon the 5th claim of said letters patent No. 186,787 the decree was for the defendants, and complainants appealed.

The defences set up in the answer, and relied upon by the defendants, are the invalidity of letters patent No. 174,465, because :

1. As a patent for a machine, the instrument or machine described and claimed is an inoperative device.

2. As a patent for a new art, there is in the patent no disclosure of what the art is, nor any description of the art process that would enable a skilled person to beneficially use it.

3. Because the claims of the patent include and appropriate mere forces of nature and things which are not subject matter of patent.

4. Because all the claims of the patent are anticipated or limited by the inventions and discoveries of Reis, Gray, Dolbear, Holcomb, Van der Weyde, McDonough, Varley and others. As to letters patent No. 186,787, the defendants' contention is :

1. That the claims are all anticipated by the inventions and discoveries of the persons named and others.

2. As to both said letters the defendants deny that they infringe any of the claims therein set forth.

Defendants say that proof of infringement was founded upon the mechanical construction of the defendant's instrument, given by Daniel M. Adee and the evidence of Prof. Charles R. Cross, that he had examined and tested the instruments marked "Exhibit Defendants' Transmitter" and "Exhibit Defendants' Receiver," and found that from their construction and method of operation they are adapted, when suitably connected with a battery, to transmit articulate speech ; and that when so connected and so operate l

## Statement of the case.

they use "the *method* invented by Bell and described in his specification No. 174,465, for transmitting vocal or other sounds telegraphically, by causing electrical undulations similar in form to the vibrations of the air accompanying any sound."

The following are the errors assigned :

"1. The Court below erred in holding that the 5th claim of patent 174,465 was valid.

"2. The Court below erred in holding that defendants infringed the 5th claim of patent 174,465.

"3. The Court below erred in holding that the 6th, 7th and 8th claims respectively of patent 186,787 were valid." Separate errors were assigned as to the holding valid of each of said claims.

"4. The Court below erred in holding that the defendants infringed the 6th, 7th and 8th claims of patent 186,787." Separate errors were assigned in respect to the infringement of each of said claims, 6th, 7th and 8th, patent 186,787. For the final decree in this case see 23 Blatchf. 253.

In the Molecular case, the validity of the 5th claim under the second patent, for a combination of a peculiarly shaped magnet and diaphragm, was questioned, but no oral argument was made upon it by either side, the claim having been sustained in the previous cases. Judge WALLACE, in his opinion in the Molecular case, adverting to the fact that this question had not been argued, said that he read the claim as a claim for a *form of magnet* which clearly was not new, but did not read it as a claim for a combination of that old magnet with a diaphragm in a speaking telephone. The same question came up, upon substantially the same evidence, in the Overland case and People's Telephone and Telegraph cases, and the complainants there argued the question, and pointed out that the claim was not for a new magnet, but was for a novel combination constituting an important improvement in speaking telephones. Judge WALLACE then sustained the claim, and decreed its validity.

## Statement of the case.

Following are the Molecular Co. patents :

(No. 52.) *Defendants' Exhibit, Lockwood & Bartlett's Patent for Transmitter for Telephones.*

J. A. Welch, Special Examiner, May 14, 1884.

ROBERT M. LOCKWOOD AND SAMUEL H. BARTLETT, OF NEW YORK, N. Y., ASSIGNORS OF ONE-HALF OF THEIR RIGHT TO CHARLES F. LIVERMORE, OF THE SAME PLACE.

## TRANSMITTER FOR TELEPHONES.

Specification forming part of Letters Patent, No. **228,824**, dated June 15, 1880; application filed March 9, 1880. (No model.)

*To all whom it may concern :*

Be it known that we, Robert M. Lockwood and Samuel H. Bartlett, both of the City, County and State of New York, have invented certain new and useful Improvements in Transmitters for Telephones or Vocal Telegraphs, of which the following is a full, clear and exact description, reference being had to the accompanying drawing, which represents our improved transmitter in section.

In the telephones as heretofore constructed the transmitting instrument, or that which receives the sound-waves and transmits them to the electrically-charged conductors, has been organized upon the theory of mechanical vibration due to the action of the sound-waves, and from this has arisen the device of a thin flexible metallic diaphragm, the vibrations of which were transmitted by the electric current to the receiver; and all telephones in what may be termed successful operation in one form or another, so far as we are acquainted with them, employ this so-called "mechanical vibration." We propose to dispense with this mechanical vibration, and as a substitute therefor we employ what we

A

(No Model.)

**R. M. LOCKWOOD & S. H. BARTLETT.**  
Transmitter for Telephones.

No. 228,824.

Patented June 15, 1880.

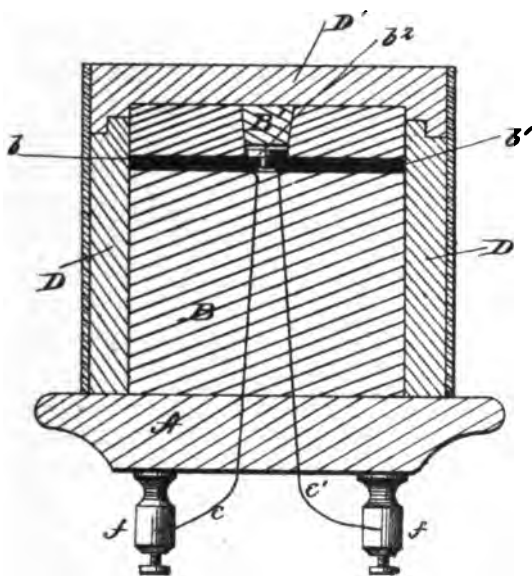

Witnesses:  
*Frank E. Ousaud*  
*Alej Mahon*

Inventors  
*Robt. M. Lockwood*  
*Saml. H. Bartlett*  
*by Edw. Smith, Atty.*

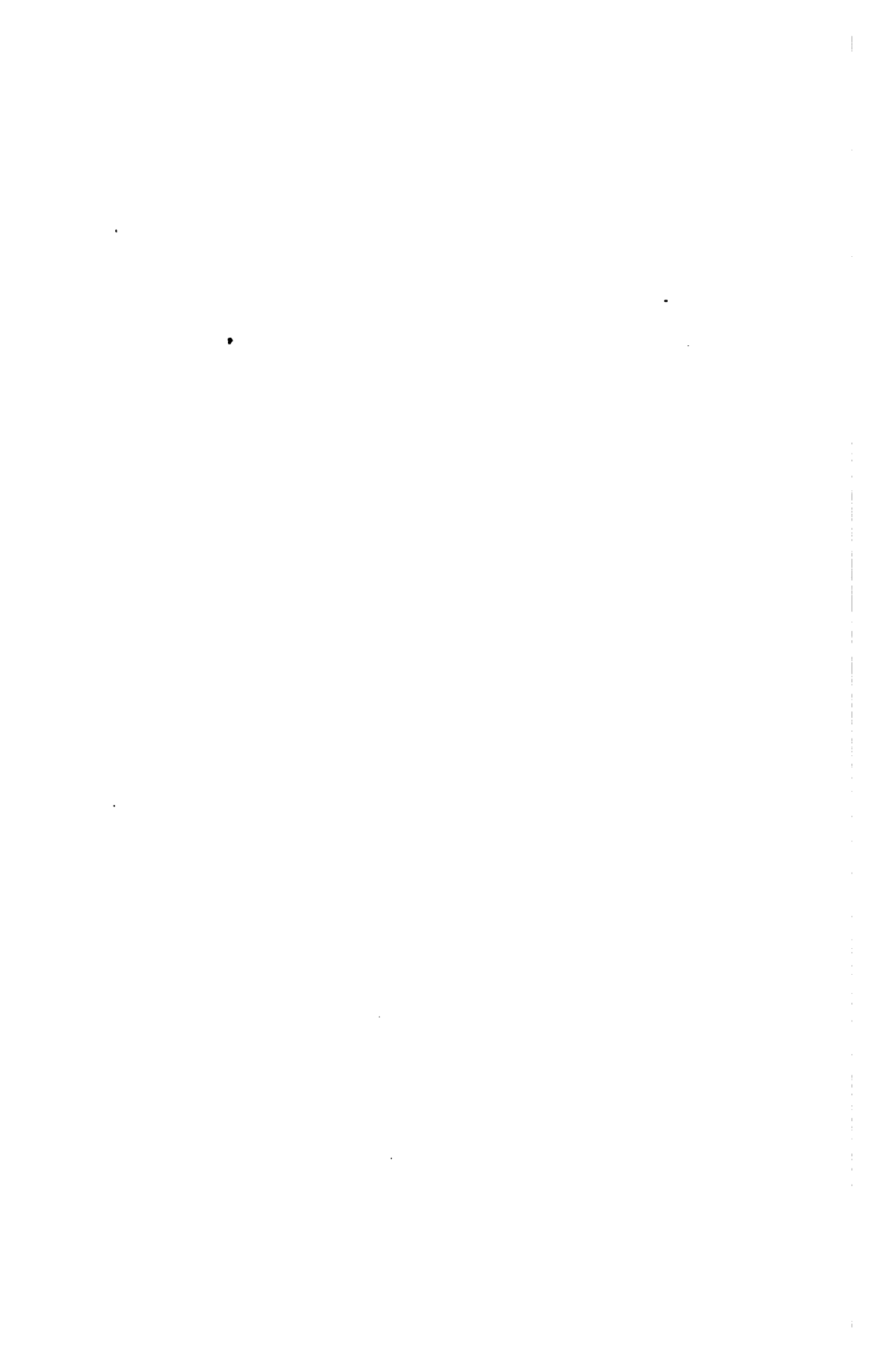



## Statement of the case.

term "molecular" disturbance or vibration, the construction of our apparatus being such as to prevent, as far as practicable, anything in the nature of mechanical vibration. This feature was partially developed in an application for letters patent filed by us November 3, 1879, but in that the carbon plates, while supported by the non-resonant material, were left uncovered at their inner adjacent ends, and sound chambers were formed in the non-resonant block on opposite sides thereof, one of which communicated with the external atmosphere, rendering the plates and the connecting button liable to be more or less affected or mechanically disturbed by the direct action of the sound-waves. In the present instance we embed the carbon or conducting plates solidly throughout their entire length in and cover or surround said plates and the button with the non-resonant material, as hereinafter explained.

In the accompanying drawing, A represents a base plate of wood, upon which is secured a block or cylinder, B, of cork or other suitable non-resonant material. Near the upper end of this block two bars or plates of carbon, *b b*, or other suitable conductors of electricity, are secured by being solidly embedded in the cork, as shown. These bars are arranged transversely of the block, extending from near its centre to or nearly to its outer face, on opposite sides, as shown. Between the inner adjacent ends of these bars is placed a headed pin of carbon or other suitable conducting material similar to that of which the bars are composed, the head of said pin constituting what we term a "button," which connects the two plates and rests upon the adjacent ends of the bars by its own gravity. A cavity is formed in the block B directly over this button, to give access to it for removing or replacing it, and this cavity, when the button is in place, is closed by a plug B', of similar material to that of which the body of the block is formed, and which rests in close proximity with and prevents accidental displacement of the button. The block B thus formed, with the carbon bars embedded

## Statement of the case.

within it, is by preference fitted snugly in a metal cylinder *D*, the open end of which rests against the base plate *A*, the other end being covered by a metal cup or cover *D'*, screwed upon or otherwise firmly secured thereto, and the metal case is in turn covered with leather, rubber, canton-flannel, or other soft non-resonant material, as shown, but the metal cylinder and its covering may be dispensed with.

Wires *e e*, are connected with the carbon plates *b b*, one to each, and extend thence out through the body *B* of the block in any convenient direction, and are connected at their outer ends to screw posts *f f* on the base plate *A*. The main-line wires connected with the battery are also connected with these screw posts in the same manner as in an ordinary telegraph instrument, and as will be seen, the wires *e e'*, carbon plates *b b'*, and button *b<sup>2</sup>* serve to connect said main-line wires and thereby complete the circuit.

The sound-waves in speaking, etc., are received upon the face or sides of the block of non-resonant material, or upon its covering described, and are communicated through said block and the carbon plates to the button *b<sup>2</sup>*, and through what we term a "molecular disturbance" the action or disturbance of the latter is communicated through the plates to the electrically charged wires *e e'*, which complete the battery circuit, and thence over the main-line wires to the point connected therewith. We thus make use of the direct current from the battery in the transmission of the sound-waves, and are thus enabled to transmit them like distances and with the same precision as an ordinary telegraphic message is transmitted.

As will be seen, our construction of the transmitter is such as is calculated to, and we believe it does as far as practicable, obviate all so-called "mechanical vibration" of the parts, for the carbon or conducting bars or plates being solidly cushioned or embedded in some firm non-resonant substance (such as cork), the disturbance caused must be other than mechanical and constitutes what we call "molecular" disturbance.

## Statement of the case.

The means for repeating or transmitting the vocal sounds over long lines or a series of circuits and for receiving the same are embraced in other applications filed herewith, and need not therefore be here described.

Having now described our invention we claim—

1. In a transmitter for telephones or vocal sound telegraphs, a block of non-resonant substance provided with strips or plates of carbon or other conducting material embedded in it, for the purpose and substantially as described.
2. The block of non-resonant material having conductors embedded within it, and wires extending therefrom for connecting them with the main line current, substantially as described.
3. The non-resonant block in which the carbon plates are embedded, in combination with the enclosing metallic case or cylinder, substantially as described.
4. The combination of the non-resonant block B, enclosing metal case D, and flexible cover thereto, substantially as described.

ROBERT M. LOCKWOOD,  
SAMUEL H. BARTLETT.

Witnesses :  
F. L. OURAND,  
ALEX. MAHON.

Statement of the case.

(No. 53.) *Defendants' Exhibit, Lockwood & Bartlett.*

J. A. Welch, Special Examiner, May 14, 1884.

ROBERT M. LOCKWOOD AND SAMUEL H. BARTLETT, OF NEW YORK, N. Y., ASSIGNORS OF ONE-HALF OF THEIR RIGHT TO CHARLES F. LIVERMORE, OF SAME PLACE.

TELEPHONE RECEIVER.

Specification forming part of Letters Patent, No. **228,825**, dated June 15, 1880; application filed April 30, 1880. (No model.)

*To all whom it may concern :*

Be it known that we, ROBERT M. LOCKWOOD and SAMUEL H. BARTLETT, of the City, County and State of New York, have invented a new and useful Improvement in Telephone Receivers, of which the following is a full, clear, and exact description, reference being had to the accompanying drawings, making part of this specification, in which—

Figure 1 represents our improved telephone or vocal sound telegraph receiver. Fig. 2 is a similar view, showing a modification in the manner of connecting the diaphragm with the magnet. Fig. 3 is an end view of the construction shown in Fig. 2, with the ear-piece and diaphragm removed, and Figs. 4 and 5 are perspective views of the end of the magnet, having one the spring arm and the other the spring arm and diaphragm applied.

Smilar letters of reference denote corresponding parts whenever used.

Our invention relates to a novel construction of the end of the magnet to which the diaphragm is connected, whereby, through disturbance or variations of magnetic power between parts of the same pole of the magnet, vocal sounds are transmitted to the diaphragm or sounding-board; and it consists

(No Model.)

**B. M. LOCKWOOD & S. H. BARTLETT.**  
Telephone Receiver.

No. 228,825.

Patented June 15, 1880.

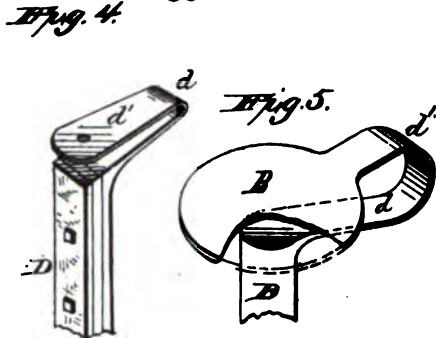
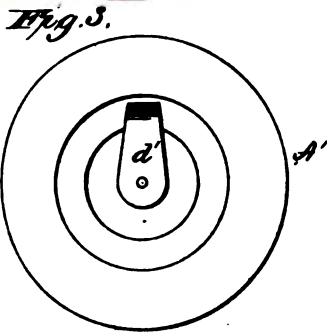
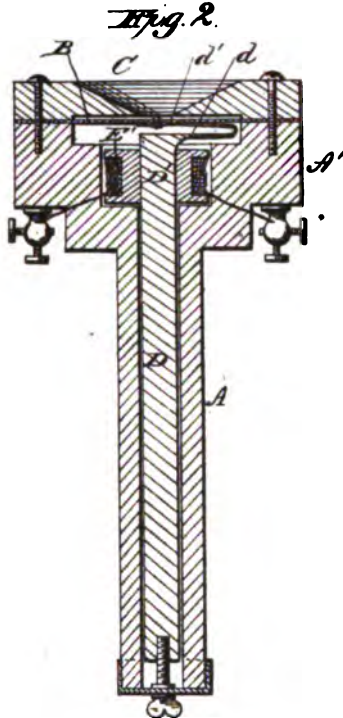
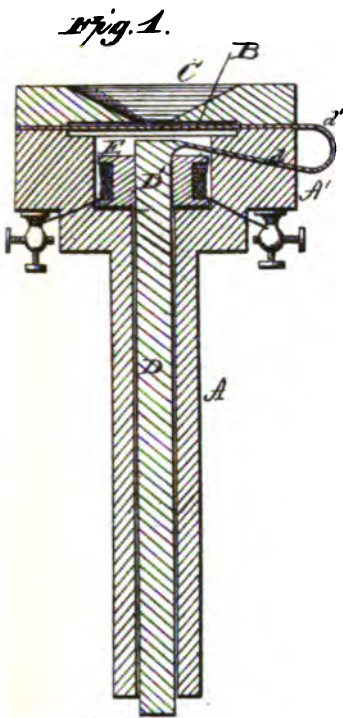

*Witnesses.*  
F. L. Oswald  
Alex. Mahon

*Inventors.*  
Robt. M. Lockwood,  
Saml. H. Bartlett,  
by A. M. Smith, Atty.



## Statement of the case.

in extending the pole in the form of a flat U-shaped spring, the outer free end of which, overhanging the end of the magnet of which it is an extension, is expanded into or has the diaphragm connected with it, as hereinafter explained.

In the accompanying drawings, A represents the body or handle of the receiver, made of wood or other suitable material, cylindrical in form, and enlarged at one end, A', to accommodate the diaphragm B and ear-piece C secured thereto.

The body or handle A is perforated longitudinally to receive the magnet D, the perforation in the enlarged end A' being enlarged into a socket for the reception of a spool or helix, E surrounding the end D' of the magnet as shown. The magnet at the end D' is drawn out, reduced in size, and bent at a right angle to the body D of the magnet, or nearly so, extends to one side thereof in the form of a flat spring, *d*, recurved upon itself in U form until the outer arm or end *d'*, overhangs the end D' of the body of the magnet, as shown.

Where the end *d'* is expanded to form the diaphragm B, as shown, the spring portion passes out through an opening in the head A', and is there recurved so as to bring the diaphragm over the end thereof, where it is held in place by the ear-piece C, which is secured to said head or ends by screws or other suitable fastening devices; but as good practical results have been obtained by making the diaphragm of different materials from the magnet, such as wood, paper, parchment, brass, &c., constituting a sounding-board, the end *d'* of the spring arm may terminate at a point overhanging the end D' of the body of the magnet, and the diaphragm or sounding-board may be bolted or otherwise firmly fastened to it, as shown in Fig. 2. Where the latter form of construction is employed the magnet should be made adjustable longitudinally by means of a thumb-screw or equivalent device, as shown, for adjusting the tension of the disc or sounding-board B as may be necessary to give it the utmost efficiency.

## Statement of the case.

Under the arrangement described it will be seen that the spring arm  $d d'$  forms an extension of the pole  $D'$  of the magnet, reduced in size, and its normal condition will be one of rest in relation thereto. Thus calling the current in the helix  $E$  one, the amount of magnetism in the magnet  $D$  at  $D'$  will be one, and that in the arm  $d'$  one, and the latter will be at rest. The body of the magnet lies within the helix, and is more easily and quickly affected by it, and constitutes, as it were, a reservoir from which the smaller arm  $d d'$  is supplied. Now, supposing the current in the helix to be suddenly increased to two, the end  $D'$  becomes two in advance of the end  $d'$ , and for the instant attracts the latter until it becomes also two, when it again instantly repels it; then its normal condition as a part of the same pole is restored, and it returns to its position of rest, until again attracted or repelled through another disturbance of the current in the helix. Thus for each disturbance in the current there will be three distinct movements of the arm  $d'$  or diaphragm  $B$  connected therewith. First, it will be drawn down or toward the end  $D'$ , then it will be repelled beyond its normal position, and finally, the equilibrium being restored, it moves back to rest. Thus it will be seen that the diaphragm is operated by differences or disturbances of degree of polarity or attraction and repulsion in the same pole.

In Fig. 4 the magnet is shown made up of a number of strips, an extension of one of which forms the spring arm. This form obviates the necessity of drawing out the body of the magnet and facilitates its construction.

We are aware that the pole or poles of a horseshoe magnet have been expanded to form a disc or diaphragm; but in such cases, so far as we are advised, the diaphragm has been brought into such relation to the opposite pole of the magnet as to be acted upon and controlled, or held under restraint, by said pole by interchange of polarity. This we do not claim; but,

Having now described our invention, we claim—



## Statement of the case.

1. The pole of the magnet extended in the form of a laterally-projecting recurved arm, and connected with the diaphragm or sounding-board substantially as described.

2. The curved spring and diaphragm, made in one piece with and forming an extension of the pole of the magnet, substantially as described.

3. The diaphragm connected with the magnet through the spring-extension of one pole of the latter, and arranged with relation to said pole substantially as shown and described.

In testimony whereof, we have hereunto set our hands this 29th day of April, A. D. 1880.

ROBERT M. LOCKWOOD,  
SAMUEL H. BARTLETT.

Witnesses:

C. H. HANKINSON,  
T. W. HARTFIELD.

## THE CLAY COMMERCIAL CASE.

April 24, 1884, the Bell Company brought a suit in equity in the United States Circuit Court for the Eastern District of Pennsylvania, against the Clay Commercial Telephone Company and others, for infringement of the above described Bell patents, Nos. 174,465 and 186,787. The defendants set up the same line of defence which had been set up in the Molecular case and other previous cases.

The Clay Commercial Telephone Company answered, denying that the said Bell was the original and first inventor of the alleged improvements described and claimed in the said letters patent, and that the same had not been known or used by others in this country, nor patented or described in any printed publication in this or any foreign country before his alleged invention or discovery, and that the same had not been in public use or on sale for more than two years prior to his said application for the said respective letters patent, but alleged the contrary thereof.

## Statement of the case.

The material allegations in the answer were as follows :

That, inasmuch as the letters patent, No. 186,787, do not bear even date with the foreign letters patent and are not limited to expire therewith, the letters patent of January 30, 1877, No. 186,787, are null and void.

That it has no knowledge that the complainants are corporations duly established under the laws of the State of Massachusetts and of the State of Pennsylvania; that the alleged title as set forth in the bill does not authorize the complainants to bring or maintain the bill, or to assert the rights and claim the relief in manner and form therein and thereby asserted and claimed; that the bill is defective for want of proper and sufficient parties thereto; and it prays that the complainants may be required to make due proof of all and singular the grants, assignments, and licenses in said bill mentioned, and of their allegations in this behalf.

It denies that electric speaking telephones had never been publicly known or used before the grant to Bell of said patent, No. 174,465; or that they were first publicly made known and introduced into public use by Bell, under the said patents No. 174,465 and No. 186,787; or that Bell was the original and first inventor of said alleged inventions.

It denies that the transmission of articulate speech, telegraphically, according to the method alleged to have been invented by Bell, and patented to him by the two several patents aforesaid, constituted an entirely new industrial art; and alleges that, on the contrary, these allegations and claims are in direct conflict with the publicly well-known and the printed and published history of telephony; that his alleged discoveries and inventions, without the aid and the employment of the inventions and discoveries of others, were incapable of accomplishing such results as those claimed in said bill, and could not produce, and never did produce, a practically effective, satisfactorily working, or commercially successful telephone; that speaking telephones arranged and constructed in the manner mentioned and set forth in said

## Statement of the case.

patent of Bell, No. 174,465, have never been put in use, are of no commercial value, and are, for practical purposes, without utility and inefficient and worthless.

It denies that it has made, used, and furnished to others, electric speaking telephones constructed according to the method described and claimed in said patents to Bell, No. 174,435, and No. 186,787, respectively; and alleges that, on the contrary, the telephones made, used, and sold by it have been made and constructed under letters patent of the United States issued and granted in conformity with law to Henry Clay, as the first and original inventor of said patented improvements, and by him duly assigned to it: to wit, May 8, 1883, No. 277,112, for a new and useful improvement in telephones; July 3, 1883, No. 280,351, for switch-board for telephones; July 3, 1883, No. 280,451, for telephone call-bell; July 3, 1883, No. 280,580, for transmitter for telephone; November 6, 1883, No. 238,017, for telephonic transmitter; that the alleged inventions or discoveries described or claimed in the said letters patent of Bell, or the substantial and material parts thereof claimed as new and original, had, prior to the alleged invention or discovery thereof by Bell, been mentioned, described, or claimed in divers letters patent granted and issued to divers persons, mentioning the persons, and mentioning among others Cromwell Fleetwood Varley; that the said respective letters patent of Bell are null and void.

This case was argued in June, 1885, before His Honor, Judge McKENNAN.

In April, 1886, the Court made a decree whereby it was decided that the several letters patent granted to Alexander Graham Bell, No. 174,465 and No. 186,787, are good and valid in law; that the said Alexander Graham Bell was the original and first inventor of the inventions described in said several letters patent, and that the said defendants have infringed the 5th claim of said letters patent No. 174,465, and the 3d, 5th, 6th, 7th and 8th claims of said letters patent

## Statement of the case.

No. 186,787, and that the defendants be perpetually enjoined from making, selling or using the said improvements.

From this decree the said, the Clay Commercial Telephone Company and other defendants appeal to this Court.

In its answer this company claims "that the telephones made, used and sold by it have been made and constructed under and in pursuance of certain letters patent of the United States, issued and granted, upon due application, and in conformity with law, unto one Henry Clay, as the first and original inventor of said patented improvements respectively, and by him duly assigned to this respondent, which said letters patent are respectively of the dates, numbers and titles following, to wit: May 8, 1883, No. 277,112, for a new and useful improvement in telephones; July 3, 1883, No. 280,351, for switch-board for telephones; July 3, 1883, No. 280,451, for telephone call-bell; July 3, 1883, No. 280,580, for transmitter for telephones; November 6, 1883, No. 288,017, for telephonic transmitter. And that the devices and methods of operation set forth in these said several letters patent are not similar to, but are wholly different from the devices described and claimed in the said letters patent of the said Bell, and are not violations or infringements of said letters patent, and do not embody or embrace the method, principle, operation or construction therein or thereby set forth, described and claimed."

## THE PEOPLE'S (OR DRAWBAUGH) CASE.

October 20, 1880, the American Bell Telephone Company sued, in equity, the People's Telephone Company, sometimes known as the Drawbaugh Company and others, for infringement of Bell's patents Nos. 174,465, and No. 186,787, in the United States Circuit Court for the Southern District of New York.

The issues made by the pleadings are practically resolved into the single question, whether the patentee Bell, or Daniel

## Statement of the case.

Drawbaugh, of Milltown, in Cumberland County, Pennsylvania, was the first inventor of the electric speaking telephone.

The defendants in this case contended that, long before Bell had perfected his invention, and long before its mental conception by him, Drawbaugh had not only made the same invention, but had perfected improvements in organization and detail which Bell never reached, and which were only reached years afterwards by the work of many other inventors in the same field of improvement. Their history of the facts is stated with substantial accuracy in the answer to the bill of complaint.

Following are the exhibits referred to in the statement of the People's (or Drawbaugh) case: \*

The answer, among other things, avers that Drawbaugh "was and is the original and first inventor and discoverer of the art of communicating articulate speech between distant places by voltaic and magneto electricity, and of the construction and operation of machines and instruments for carrying such art into practice; \* \* \* that the said electric speaking telephones so constructed and successfully and practically used by him contained all the material and substantial parts and inventions patented" in the two patents granted to Bell; and also contained other important and valuable inventions in electric and magneto telegraphy; \* \* \* "that some of the original machines and instruments invented, made, used and exhibited to many others long prior to the alleged inventions of Bell are still in existence, and capable of successful practical operation and use, and are identified by a large number of persons who personally tested and used and know of their practical operation and use in the years 1870, 1871, 1872, 1873, 1874, and both subsequently and prior

\* See pages 69-98 for Drawbaugh Exhibits F, B, C, I, A, D, E, L, M, O, G, and pages 105-109 for Exhibit H and description.

## Statement of the case.

thereto; \* \* \* that said Drawbaugh for more than ten years, prior to 1880, was miserably poor, in debt, with a large and helpless family dependent upon his daily labor for support, and was from such cause alone utterly unable to patent his said invention or caveat it, or manufacture and introduce it upon the market; and that said Drawbaugh never abandoned nor acknowledged the claims of any other person thereto, but always persisted in his claim to it, and intended to patent it as soon as he could obtain the necessary pecuniary means therefor.

Drawbaugh, in his testimony, describes instruments which he says were made by him from time to time, as experiments led him from one improvement to another. He testifies that he thinks he made his first telephone apparatus prior to November, 1866, and is positive he had it before he moved his shop to the "Clover Mill" in 1867.

As he describes it, the body of the transmitter was a porcelain tea-cup, the diaphragm was of membrane, the electrodes interposed in the circuit were two copper discs, the upper one of which was connected to the diaphragm by a wire, so as to vary its pressure upon a low conductor of fine earth or pulverized charcoal interposed between the discs through the action of the sound-waves upon the diaphragm; and the receiver was a tin can without a top or bottom, having a membrane diaphragm stretched over one end, connected by a tense cord to an armature supported on a spring, and arranged close to the poles of an electro-magnet in the electric circuit. He testifies that subsequently he constructed apparatus upon the same general principle, with some change of detail; and he produces "Exhibits F and B"—the former a transmitter and the latter a receiver—as the remnants of the original instruments. "Exhibit F" is a glass tumbler; and he states that at first he used a membrane diaphragm over it, and then one of thin metal; and that for the conductor he used pulverized carbon or carbon mixed with bronze powder, and used various tops or mouth-pieces to speak into it. The "Exhibit B," he

*Instrument marked F Reproduced  
Harrisburg August 8th 1881.*

*W. H. H. Knight.*

*"Full size"*

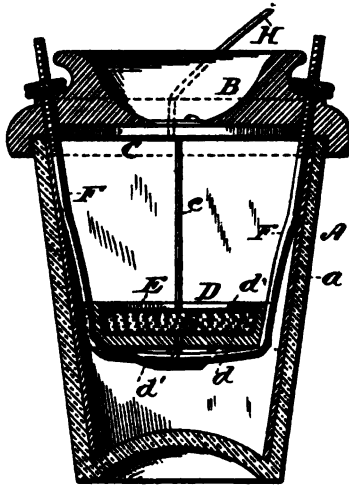

*References.*

- |  |  |
|--|--|
| <i>A. Glass tumbler.</i>                 | <i>d'. Wire from plate d to adjusting posts.</i> |
| <i>a. Plaster-paris lining to same.</i>  | <i>E. Upper metallic plate in cup D.</i>         |
| <i>B. Wooden mouthpiece.</i>             | <i>C. Bar from plate E to diaphragm.</i>         |
| <i>C. Diaphragm; tin.</i>                | <i>F. Adjusting posts.</i>                       |
| <i>D. Carbon holding cup; wood.</i>      | <i>G. Carbon in cup D.</i>                       |
| <i>d. Metallic plate at bottom of D.</i> | <i>H. Conductor to diaphragm.</i>                |

*Note.*

*The conductor H is attached to the edge of the diaphragm; the opposite edge of the diaphragm is notched, to allow passage for a conducting wire (not on instrument) through the cap to the wire d.*





*Instrument marked F full size  
Harrisburg Pa. June 15<sup>th</sup> 1881*

*W. H. H. Knight,  
Del.*

*Longitudinal section*

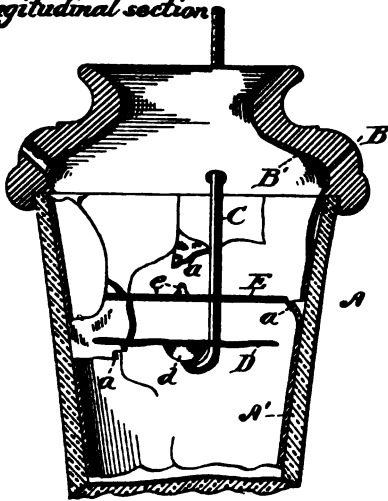

*Cap top view.*

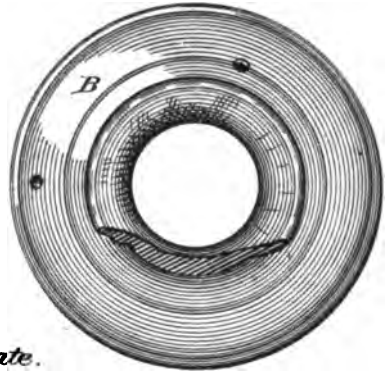

*Lower plate.*

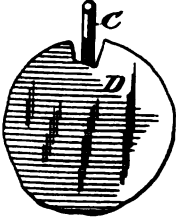

*Upper plate.*

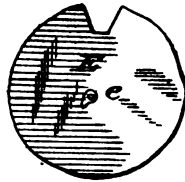

*References.*

- A. Glass tumbler; bottom broken off.*
- B. Wooden cap.*
- B'. Plaster-paris lining to cap.*
- A'. " " " " tumbler.*
- a. Breaks in lining A'.*
- C. Adjusting rod for lower plate.*
- D. Lower plate.*
- d. Solder joint.*
- E. Upper plate.*
- e. Wire to plate E.*

*W. H. H. Knight,*



Instrument marked B full size  
 Harrisburg Pa June 8th 1881.  
 W. H. N. Knight.  
 del.

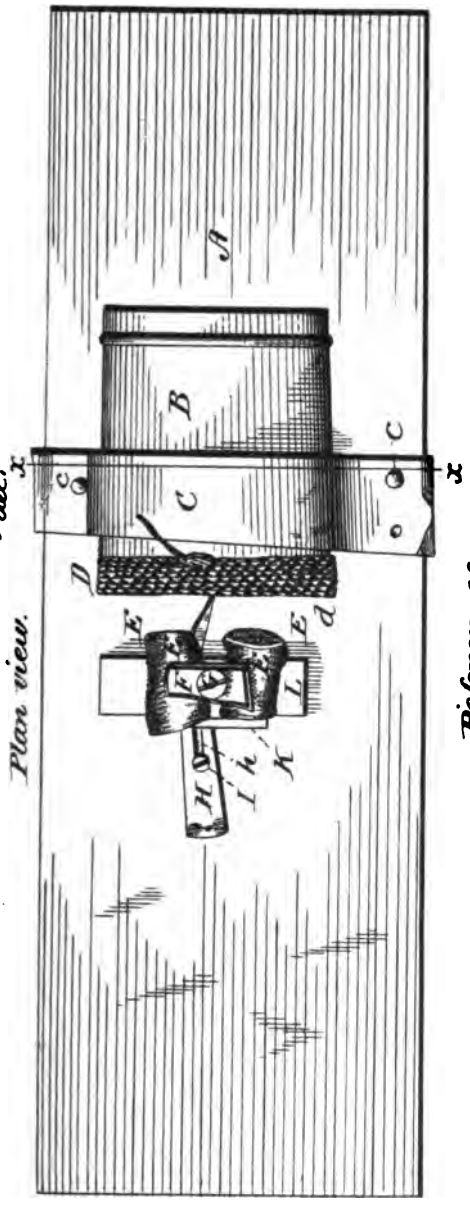

References.

- A. Base board, of pine.
- B. Tin box, evidently a mustard box.
- C. Strap of tire.
- D. Irune wrapped, about box, to hold membrane composing diaphragm in place.
- d. Projecting edges of membrane.
- E. Electro-magnets.
- F. Retaining plate of copper.
- G. Screw securing same to base board.
- H. Tension plate, to tighten diaphragm.
- I. Slot in same.
- J. Regulating screw in slot h.
- K. Plate to which magnets are attached, to 3/32 of an inch in thickness; the lining is broken away at different points.
- L. Wooden block upon which magnets rest.
- M. Plaster of paris lining to box from 1-16



*Side elevation.*

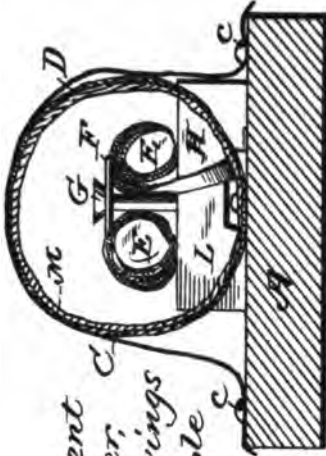
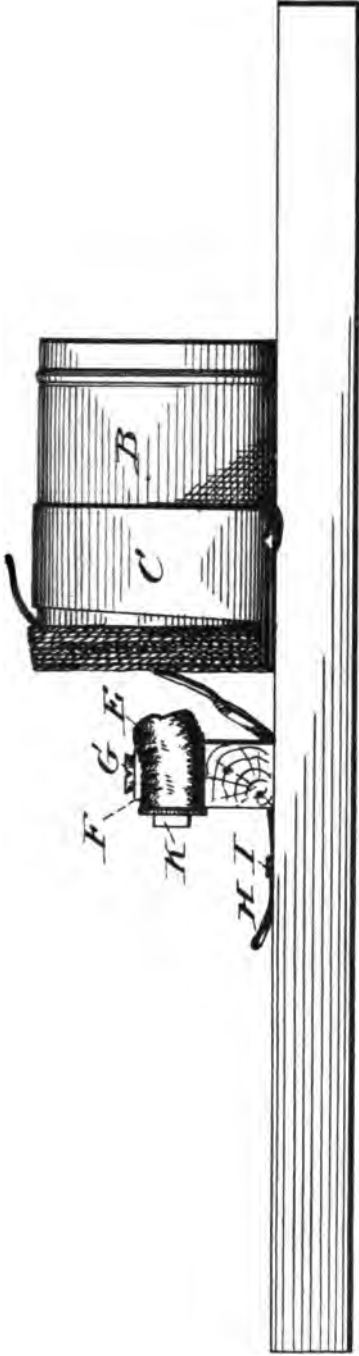

*Section on line x-x.*

*Note.*  
Portions of this instrument are so much out of order, as to render perfect drawings of its appearance impossible to make. I have followed as nearly as possible the originals.



*Instrument marked C full size  
Harrisburg June 23<sup>rd</sup> 1881.*

*U. H. H. Knight,  
Del.*

*Top elevation.*

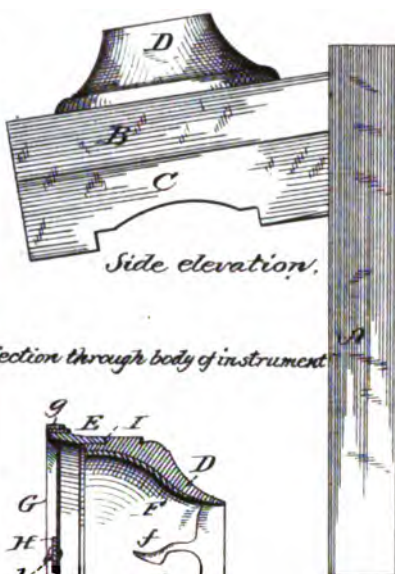
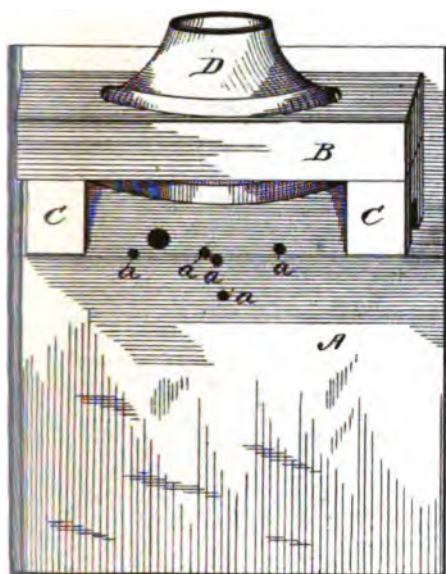

*Section through body of instrument*

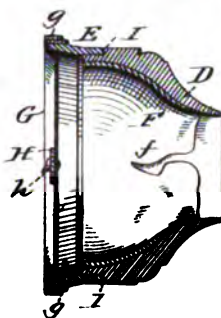

*References,*

- |  |   |
|--|---|
| <i>A. Base of instrument.</i>                        | <i>a. Screw holes in base A.</i>            |
| <i>B. Upright board to hold instrument.</i>          | <i>C. Nails holding B. and C. together.</i> |
| <i>C. Braces to support B.</i>                       | <i>E. Rim at rear of D.</i>                 |
| <i>D. Body of instrument.</i>                        | <i>F. Breaks in F.</i>                      |
| <i>F. Plaster-paris lining to D.</i>                 | <i>G. Band surrounding flange of G.</i>     |
| <i>G. Diaphragm; tin.</i>                            | <i>H. Wire attached to H.</i>               |
| <i>H. Armature attached to G.</i>                    |   |
| <i>I. Auxiliary diaphragm of gold beater's skin.</i> |   |

*Note,*

*A second, or auxiliary diaphragm of gold beater's skin, was originally used in this instrument, said diaphragm being held in place by the rim E. Portions of this diaphragm still remains, attached to the body by said flange I.*





• *Front elevation.*

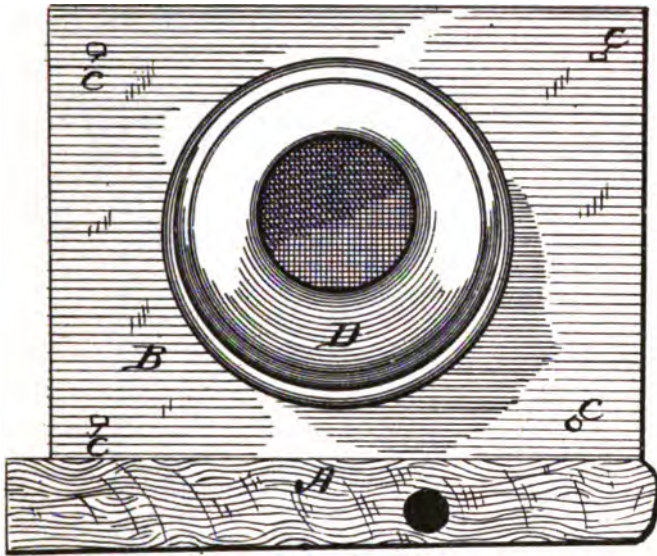

*Rear elevation.*

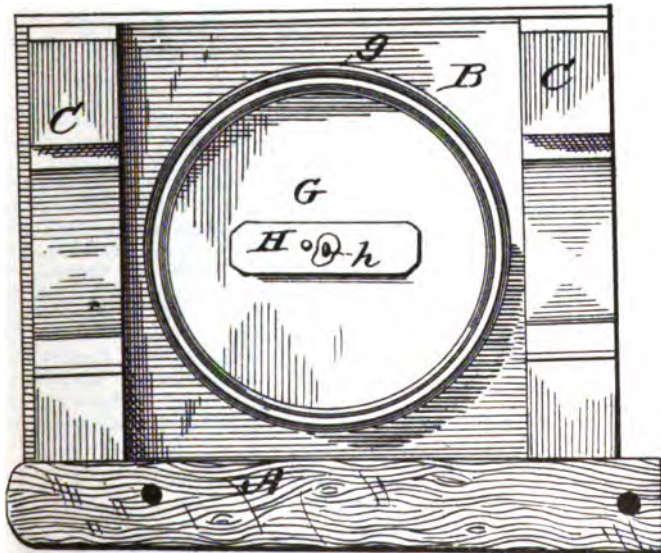



Reproduced instrument marked full size.  
 Harrisburg Pennsylvania July 13th 1881.  
 Reproduction of instrument C U. H. N. Knight.  
 Plan view.

Side elevation of base board,  
 magnet, and its supporting blocks.

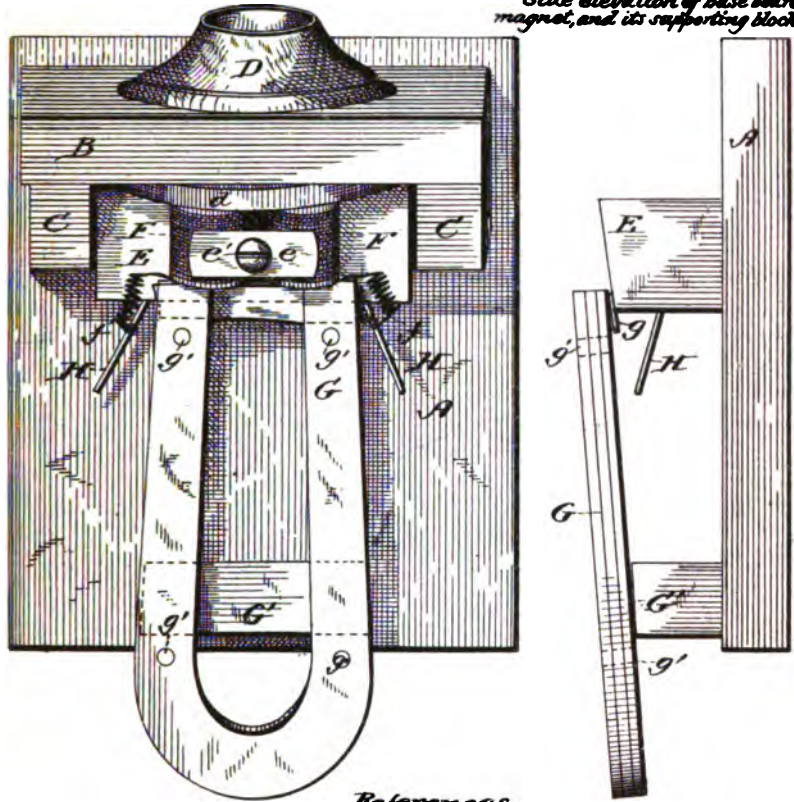

*References.*

- A. Base board.
- B. Upright to hold body of instrument.
- C. Supports of B.
- D. Body of instrument.
- d. Band on rim of D to hold diaphragm in place.
- E. Block to support electro-magnets.
- e. Plate to hold electro-magnets in place, brass.
- c. Screw to secure e and E to A.
- F. Electro-magnets.
- f. Wires to F.
- G. Permanent magnet.
- G'. Block to support G.
- g. Paper to raise end of G.
- g'. Rivets in G.
- H. Stads in block E to receive wire.

*Note.*

This instrument is similar in all respects to original instrument marked C, having armature attached to diaphragm; therefore I have thought two views sufficient in this case.



*Instrument marked I one form  
Harrisburg July 12<sup>th</sup> 1881.*

*W. H. N. Knight.  
Del.*

*Longitudinal section showing  
electro-magnets and diaphragms.*

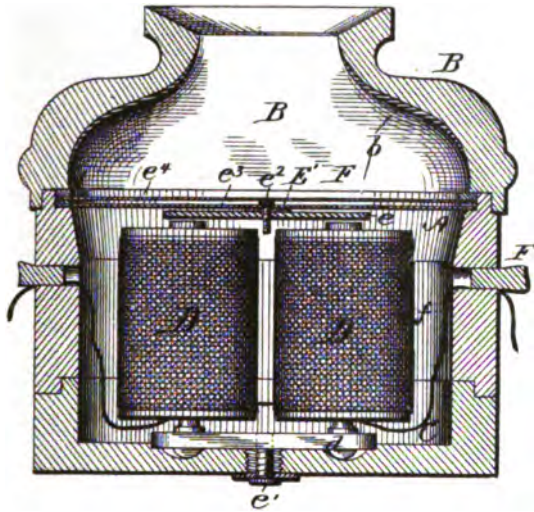

*References.*

- H. Body of instrument; black walnut.*
- B. Cap of instrument.*
- b. Plaster-paris lining to B.*
- C. Lower cap.*
- D. Electro-magnets.*
- d. Bar supporting magnets.*
- E. Upper diaphragm.*
- E'. Lower diaphragm.*
- e. Armature of magnets.*
- e'. Screw holding d in place.*
- e2. Screw holding E' to e.*
- e3. Paper ring between E and E'.*
- e4. Paper ring or gasket above E.*
- F. Plugs to hold wire.*
- f. Wires or conductors.*

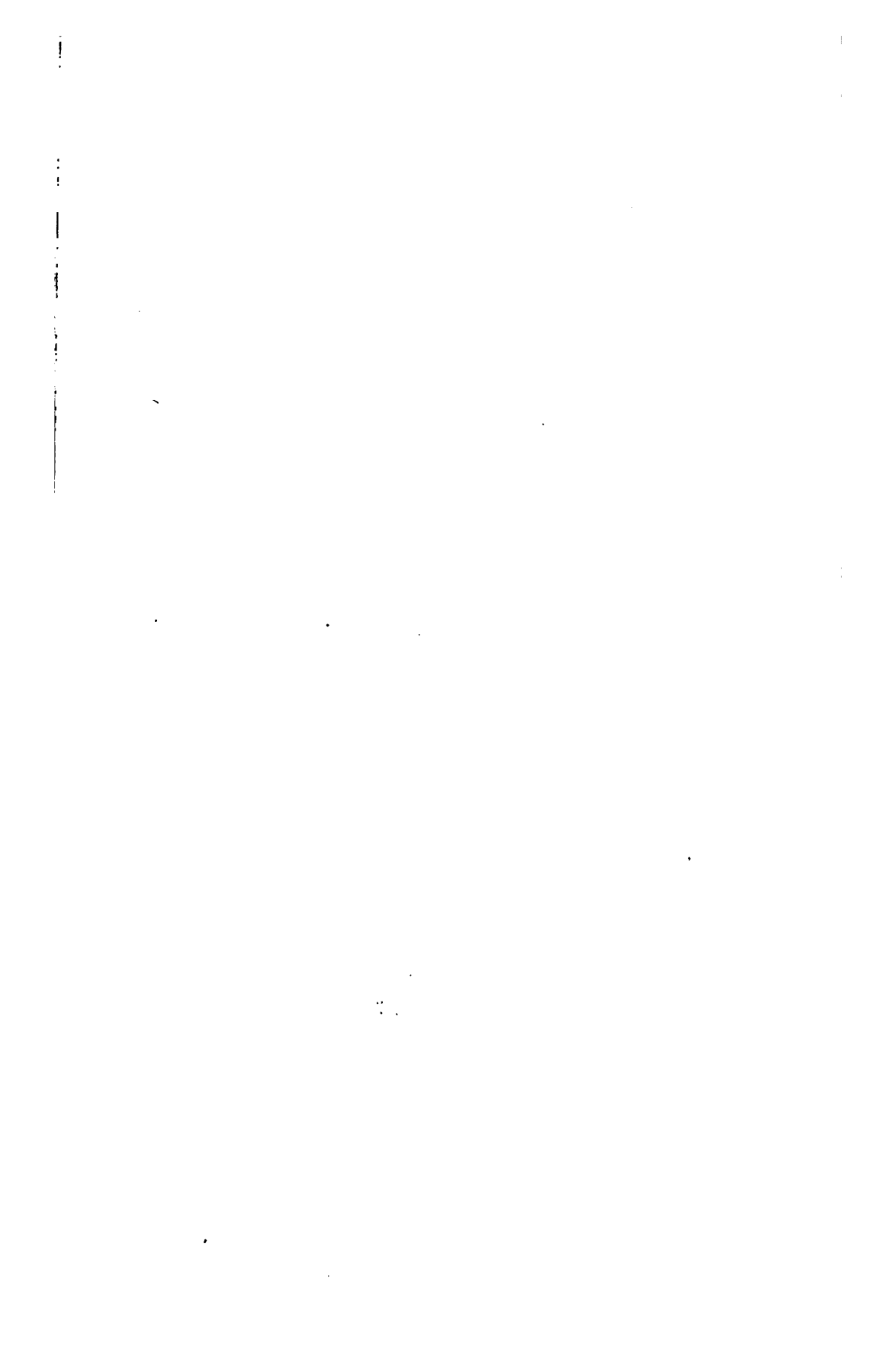

*Instrument marked A full size  
Harrisburg Pa. May 2<sup>nd</sup> 1881.*

*W. H. H. Knight,  
Del.*

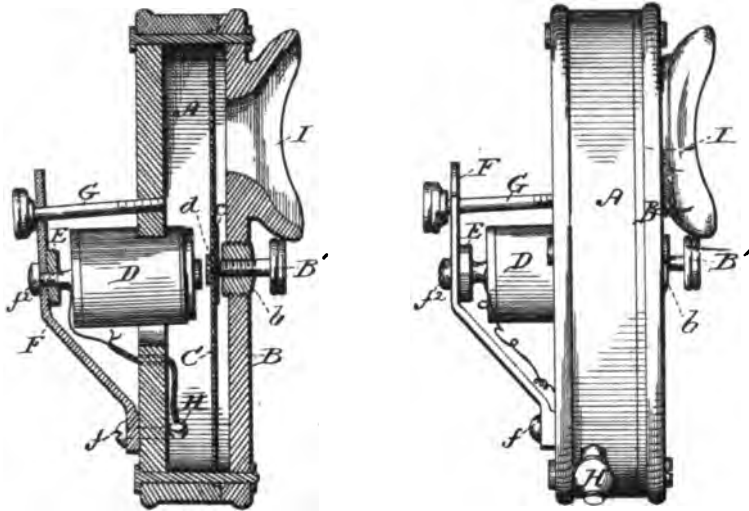

*References.*

- A. Case of black walnut.*
- B. Cover or cap to same.*
- B'. Adjusting screw for diaphragm; brass.*
- b. Screw block in cap through which B' passes.*
- C. Diaphragm; of thin black walnut.*
- c. Rubber cemented to C.*
- D. Electro-magnets.*
- d. Armature on diaphragm.*
- E. Plate connecting magnets.*
- F. Bracket to support magnets.*
- f. Screws securing same to case.*
- f'. Screw holding plate B to bracket.*
- G. Adjusting screw for bracket.*
- H. Screw cups.*
- I. Mouth or ear piece.*
- i. Conductors or wires.*

*W. H. H. Knight,*





*Instrument marked "D"*

*Harrisburg Pa.*

*June 12<sup>th</sup> 1881.*

*W. H. H. Knight.*

*Del.*

*Front elevation.*

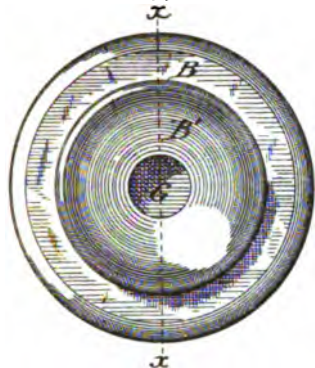

*Side elevation.*

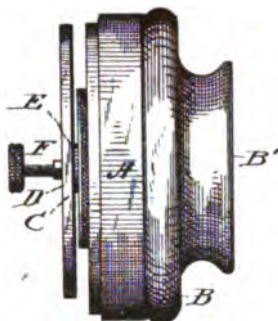

*Rear elevation.*

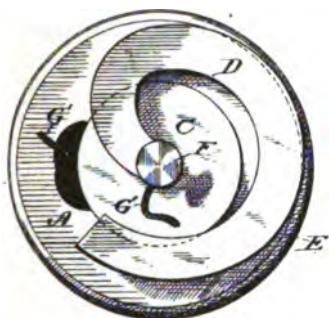

*Section on line x, x.*

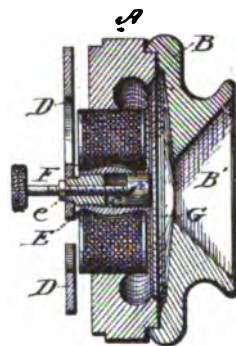

*References.*

*A. Body of instrument.*

*B. Cap of instrument.*

*B'. Mouthpiece.*

*C. Electro-magnet.*

*c. Hollow core of C; iron.*

*c'. Adjustable plug in c.*

*D. Permanent magnet.*

*E. Screw plug to support D.*

*e. Jam nut on adjusting screw.*

*F. Adjusting screw for c'.*

*G. Diaphragm; tin.*

*G'. Conductors or wires.*

*W. H. H. Knight.*



*Instrument marked E full size  
Harrisburg Pa. Jan 13<sup>th</sup> 1881.*

*W. H. H. Knight.*

*Front elevation.*

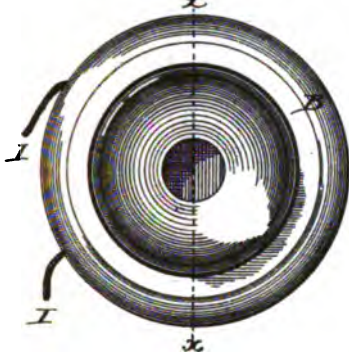

*Side elevation.*



*Rear elevation: cap off. Section on line x.x.*

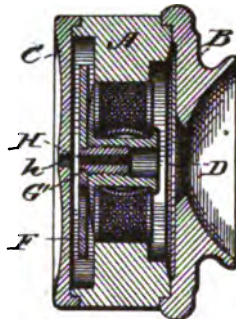
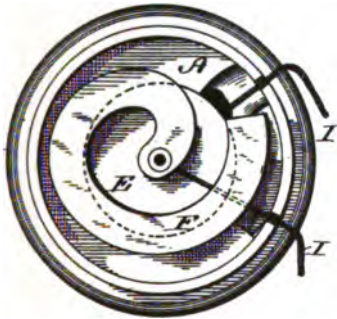

*References.*

- A. Body of instrument.*
- B. Cap of instrument.*
- C. Rear cap of instrument.*
- D. Diaphragm.*
- E. Electro-magnet.*
- F. Permanent magnet.*

- G. Hollow core of E; iron*
- G'. screw plug to support*
- E,*
- H. Female screw in G',*
- K. Aperture in C,*
- I. Wires.*

*W. H. H. Knight.*

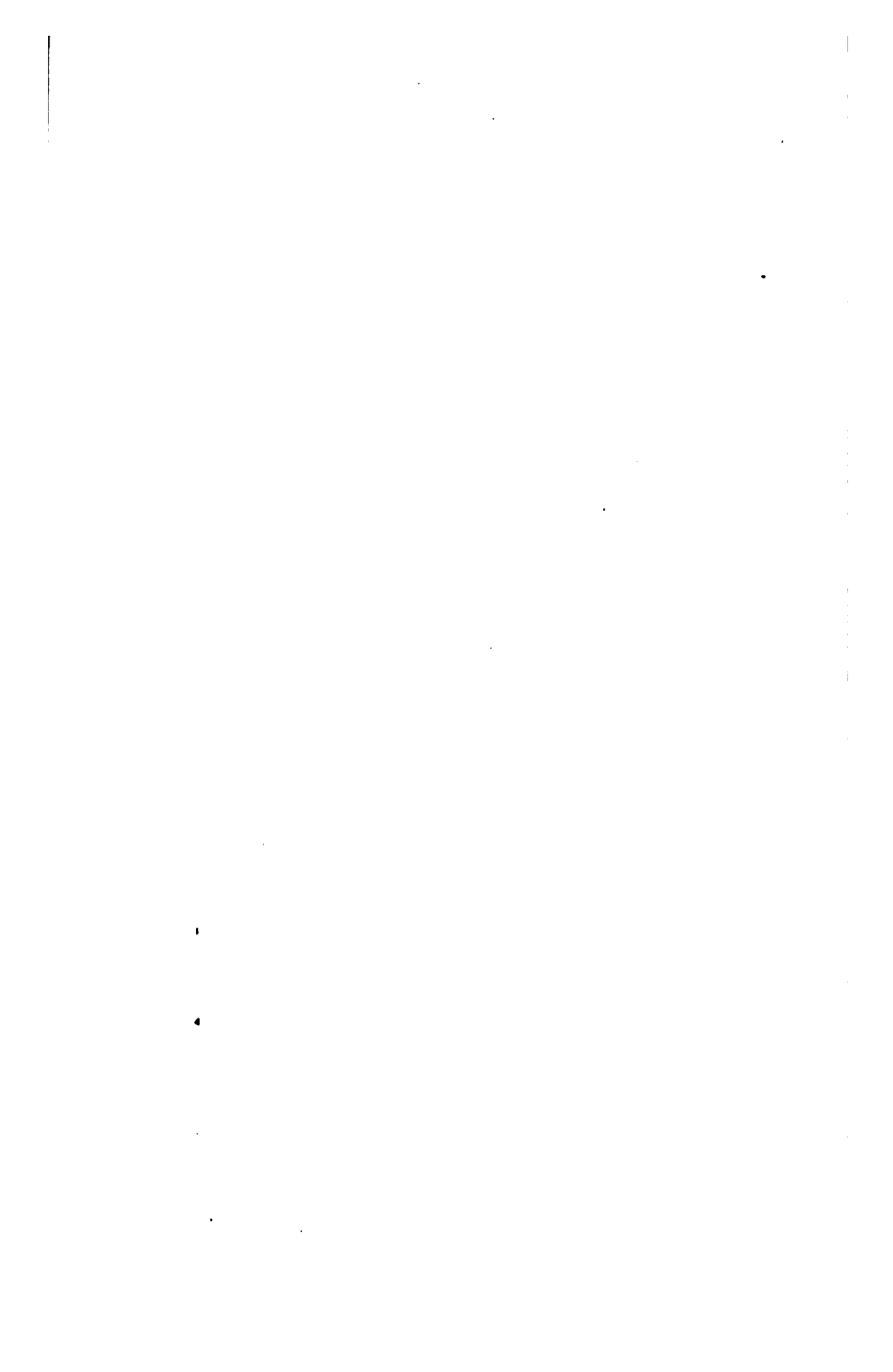

*Instrument marked I full size  
Harrisburg Pa, June 29<sup>th</sup> 1881.*

*W. H. H. Knight.  
Oct.*

*Top view cap and  
diaphragm removed.*

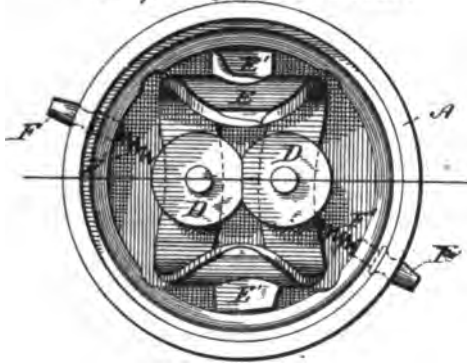

*Section on line x.x.*

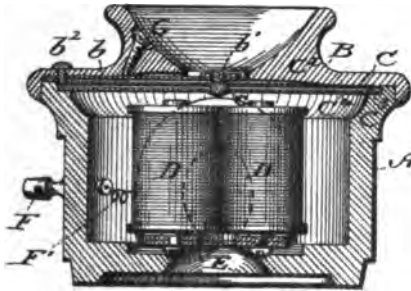

### *References.*

- |   |  |
|---|--|
| <i>A. Body of instrument.</i>           | <i>B. Cap of same.</i>                       |
| <i>b. Pressure spring.</i>              | <i>b'. Metal block on spring.</i>            |
| <i>b². Rivet in same.</i>               | <i>C. Compound diaphragm; top part.</i>      |
| <i>C. Upper diaphragm.</i>              | <i>C'. Lower diaphragm.</i>                  |
| <i>C². Perforations in C'.</i>          | <i>c. Rivet connecting C and C'.</i>         |
| <i>C³. Paper ring between C and C'.</i> | <i>D. Electro-magnets.</i>                   |
| <i>E. Permanent magnets.</i>            | <i>E'. Wooden wedges to hold E in place.</i> |
| <i>F. Binding posts.</i>                | <i>F. Wires from D to E.</i>                 |
| <i>G. Adjusting screw to spring b.</i>  | <i>b². Rivet holding spring b to cap.</i>    |

### *Note.*

*The upper diaphragm is made of copper,  
perforated; the lower one is made of iron.*



*Instrument marked M full size  
Harrisburg Pa. June 28<sup>th</sup> 1881.*

*W. H. H. Knight-  
Del.*

*Top view, cap and  
diaphragm removed.*

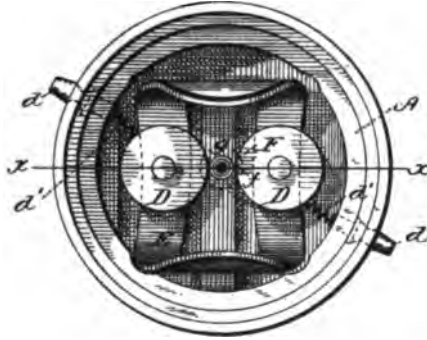

*Longitudinal section  
on line x-x, top view.*

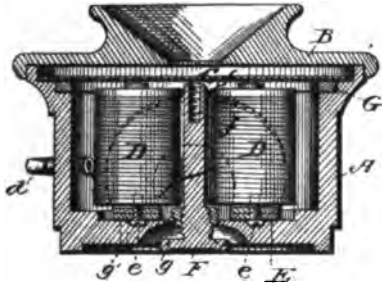

*References.*

- |                                    |  |
|------------------------------------|--|
| <i>A. Body of instrument.</i>      | <i>B. Cap of instrument.</i>                             |
| <i>C. Diaphragm.</i>               | <i>D. Electro-magnets.</i>                               |
| <i>d. Binding posts.</i>           | <i>d'. Wires.</i>  |
| <i>E. Permanent magnet.</i>        | <i>e. Screws connecting E to D.</i>                      |
| <i>F. Adjusting screw or post.</i> | <i>f. Recess for screw in end of F.</i>                  |
| <i>G. Rubber ring.</i>             | <i>g. Nut in end of body A for<br/>adjusting post F.</i> |
| <i>g'. Screw to secure B to A.</i> |  |

*Note.*

*The magnet E is secured to the body of the instrument by screws, one of which is shown by dotted lines at g'.*

*At one time the diaphragm of this instrument was made of tin, and was rigidly attached to the post F by a screw which entered the recess f in the post F.*





*Instrument marked O full size  
Harrisburg Pa. June 20<sup>th</sup> 1881.*

*W. H. H. Knight.  
Del.*

*Side Elevation.*

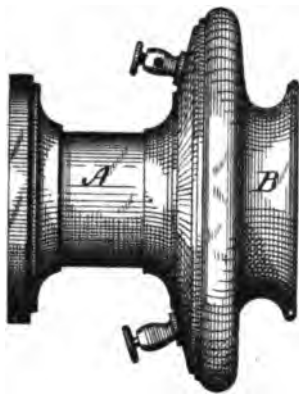

*Longitudinal section.*

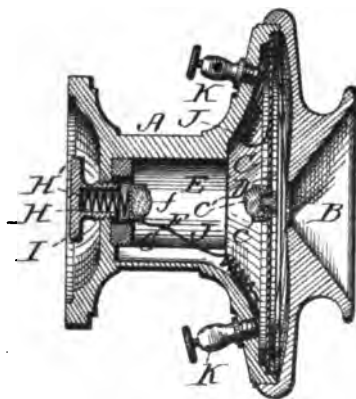

*References.*

- A. Body of instrument.*
- B. Cap of same.*
- C. Diaphragm.*
- c. Carbon cup on diaphragm; brass.*
- c'. Carbon ball in cup c.*
- D. Cardboard ring.*
- E. Recess for carbon holder.*
- F. Lower carbon cup; brass.*
- f. Carbon ball in same.*
- G. Wood ring.*
- H. Recess in adjusting screw.*
- H'. Spiral spring in same.*
- I. Screw; adjusting.*
- J. Wires or conductors.*
- K. Screw cups.*

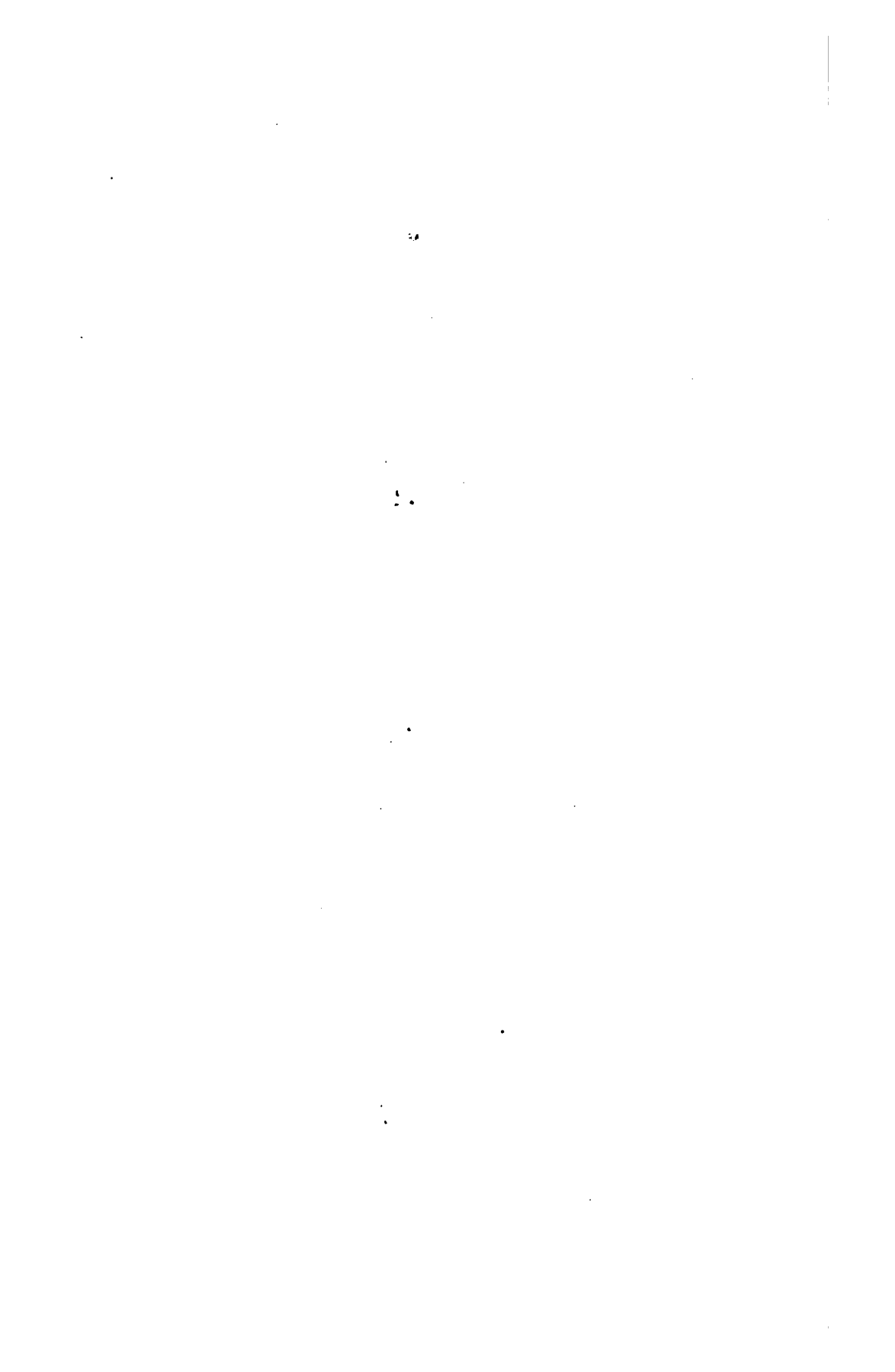

*Instrument marked G full size  
Harrisburg Pa. June 16<sup>th</sup> 1881.*

*W. H. H. Knight.  
Del.*

*Side elevation.*

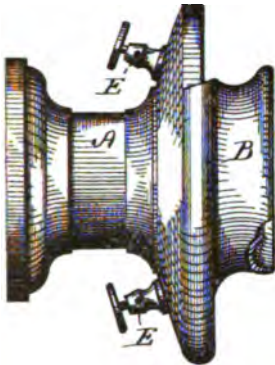

*Top plan view.*

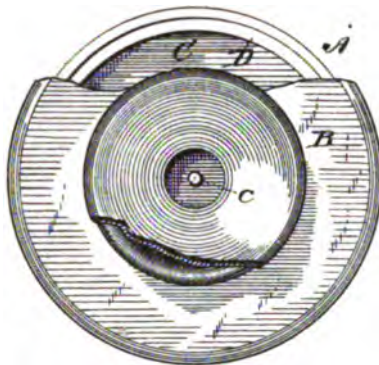

*Longitudinal section.*

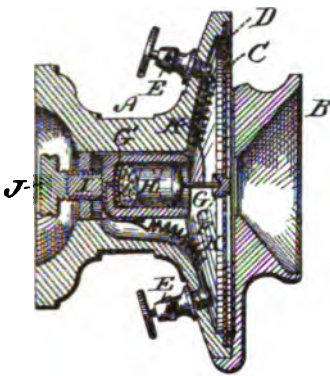

*Fragment of cap.*



*References.*

- |                                     |   |
|-------------------------------------|---|
| <i>A. Body of instrument.</i>       | <i>F. Carbon holder; wood.</i>              |
| <i>B. Cap of instrument.</i>        | <i>GG. Contact tips.</i>                    |
| <i>C. Diaphragm.</i>                | <i>H. Carbon ball.</i>                      |
| <i>c. Contact cup on diaphragm.</i> | <i>I. Rubber spring in adjusting screw.</i> |
| <i>D. Paper ring.</i>               | <i>J. Adjusting screw.</i>                  |
| <i>E. Screw cups.</i>               | <i>K. Conductors.</i>                       |

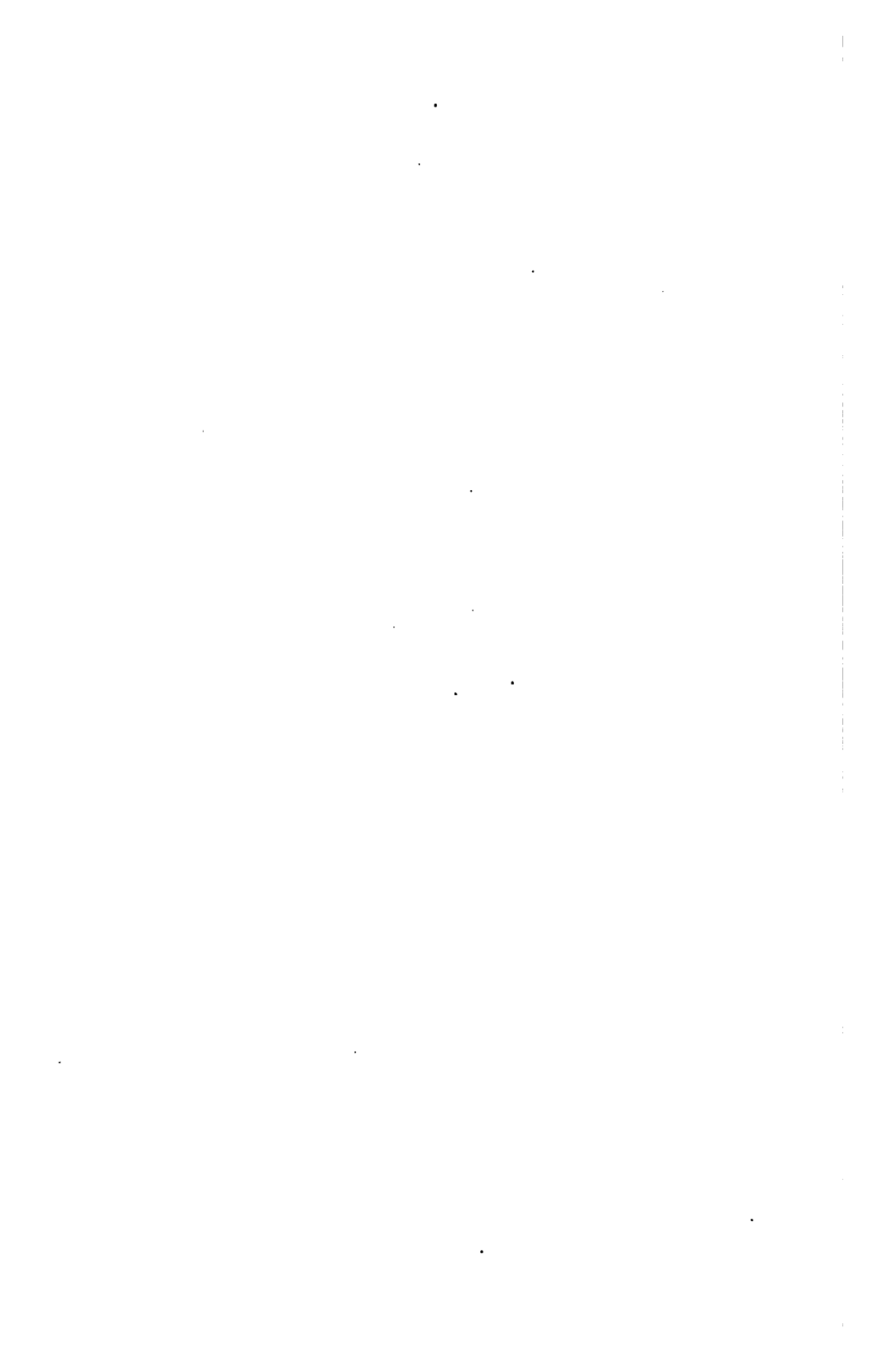

## Statement of the case.

says, was the receiver; and in this he had discarded the string and the spring of his earlier receiver. He says that experiment led him to improve the transmitter F by substituting a metal diaphragm in place of membrane, and he produces a sketch. A reproduction of this instrument has been made by him for use in the proofs, which is designated as "Exhibit F" reproduced. In this the mouth-piece is modified in size and in distance from the diaphragm.

He made, according to his testimony, a new receiver of more perfect construction, and produces the remnant of the original, which is designated as "Exhibit C."

A reproduction of such an instrument as he describes is made and referred to in the proofs as "Exhibit Reproduced C." After "Exhibit C," he produces "Exhibits I, A, E, and D," as likewise original instruments, made respectively in the chronological order of their production as exhibits. He states that "I" was used by him as a companion instrument to "C." "Exhibit A" discloses a modification of form and a higher degree of mechanical adaptation.

The last two, "D" and "E," are concededly perfect, practical instruments, and, according to the testimony of Mr. Benjamin, an expert witness for the defendants, would compete successfully for public patronage with any magneto telephone which had been introduced into use in 1882. It is asserted of these instruments by counsel that no higher development of the magneto telephone has been reached at the present time than is indicated by "Exhibits E and D." Drawbaugh does not attempt to fix the time at which he made any of these instruments, or even the year. He testifies, however, that he made all of them prior to the time the Axle Company commenced business, which was in December, 1874, except "E" and "D," which were made about that time.

The theory of the defendants is, that "Exhibits F and B" were used by Drawbaugh in 1867, 1868 and 1869; "Exhibit C," in 1869 and 1870; "Exhibit I," in 1870 and 1871; "Ex-

## Statement of the case.

hibit A," in 1873 and 1874, and that "Exhibits E and D" were made in January, or February, 1875.

The defendants introduce the testimony of nearly two hundred witnesses tending to prove the priority of invention by Drawbaugh.

The general theory of the defence is substantiated by three classes of witnesses; those who heard of the existence of Drawbaugh's "talking machines" at various times; those who talked through the machines on various occasions, or heard others talk through them; and those who attempt to identify one or more of the exhibits as the instruments they saw used. More than fifty witnesses testify to having heard of the talking machines prior to February 14, 1879.

Sixty witnesses do not attempt to identify any particular instrument, but testify that they saw a talking machine, or talked through it, or heard it talked through at Drawbaugh's shop on occasions subsequent to 1867, and most of them fix the occasion as prior to 1876.

The third class of witnesses is those who identify more or less positively one or more of the several exhibits as the instruments used by them, or which they saw used by others prior to March 7, 1876. "Exhibits F and B" are identified by over forty witnesses.

The identification of "Exhibits C, I and A" is made by a smaller number of witnesses. Some of them think they saw "C" in 1870, and others at various dates after that and as late as March, 1876.

One of the witnesses thinks he saw "I" in 1871; the others locate the occasions in 1873, 1874 and 1875. Some of the witnesses think they saw "A" as early as 1872, one of them in 1870; but most of them saw it, they think, in 1875.

Some of the witnesses who identify one or more of the instruments exhibited to them by Drawbaugh as the "Exhibits F, B or C," saw or used them in 1875 or 1876.

That the talking machines referred to by the witnesses were electric instruments is clearly established. Drawbaugh

## Statement of the case.

testifies explicitly that they were always used with a closed circuit, and without breaking the current, some of them being battery telephones, and some magneto telephones. He always represented them as actuated by electricity, to those to whom he explained or described them, and claimed his invention would supersede the telegraph. His assertions show them to have been electrical instruments.

He stated to the witness Shank "it was the greatest invention ever known. If he had the means to go on with it, they could talk, or rather be a time to come as to talk, to the old country, same as we can talk here." To Zacharias, that "he could run it out for miles, and parties could talk in at one end and be heard at the other end, the same as persons in a room together." To Smith, that "parties between Harrisburg and Philadelphia could communicate as if they were speaking together; there would hardly be any limits;" it was an "instrument to convey the voice, to supply the place of the telegraph;" to Smyser, that it would work "from here to California;" to Fry, that one "can talk as far as the wire goes;" to Carl, that "he could hear a man talk from that place to New Cumberland or Harrisburg, and understand distinctly what he said;" to Sherwick, that it was "better and handier than the telegraph; that you could just talk through it in place of writing;" to Balsley, that "by attaching two wires you can hear it away off; the telegraph is nowhere with it;" to Kahney, that "he could talk the same for miles as he could for a short distance;" to Shettel, that, "if he had a wire from the shop in connection with the telegraph wires at White Hill, he could talk to Mechanicsburg by having a machine there or an instrument in the office; that it would be better than telegraphing, and that it would be worth a great deal of money;" to Reneker, that "he thought he could make it that he could talk through to Harrisburg; he thought they would take the place of telegraphing;" to Weber, that "it beats all the others of my inventions; he could carry sound, or rather talk, as far as

## Statement of the case.

Shiremanstown;” to Hawn, that “he would be able to operate, that a man preaching in New York, that a congregation in Philadelphia would hear the same sermon;” to Kahney, that “he could just as easy speak ten miles as one, or any distance he would choose to;” to Rupp, who was there with Hamacher, that “it was worked by electricity, would take the place of the telegraph, and that he could make it so that he could talk to San Francisco;” to Musser, that “he was going to make a machine to talk from Harrisburg to Philadelphia, and it would be cheaper and quicker way than telegraphing;” to Smith, that “he believed they could talk for a hundred miles;” to Fetterow, that “I could speak ten, fifteen or twenty miles, or even to California, if there was a wire extended;” to Wisler, that “he could attach a wire to it and talk for ten miles, as far as he could have a circuit around;” to H. F. Drawbaugh, that “he could talk across the continent;” to Free, that “the talking machine could be used to talk at a long distance—from Philadelphia to California;” to Landis, “that it could be used a thousand miles; it would take the place of the telegraph;” to Lenig, that “he could talk hundreds of miles through that;” to Updegraff, that “instead of using the old mode of telegraphing, he could talk directly through the wire; he thought he could talk as far as you could use the ordinary telegraph wire;” to Draper, that “he thought it was, or would be, one of the greatest inventions of the age, and would take the place of telegraphing;” to A. Evans, that “he could take this machine and talk clear out to Europe, cross the ocean;” to Eicholz, that “if he could only get some one to help him once, he would run it to Harrisburg, and convince them, and then he would run it from Harrisburg to Philadelphia.”

He stated to the witness Shank, that “it works by electricity;” to Smith, “it was by electricity;” to Nichols, that “the sound was conducted by electricity;” to C. Eberly, that the instruments were “to convey sound by electricity;” to Coudry, that “they were operated by electricity;” to



## Statement of the case.

Shoop, that "it operated by a battery;" to Shireman, that "they operated by magnetism;" to Hawn, that "they would be operated on by a battery;" to N. W. Kahney, that "the machine was operated by electricity, by a battery;" to Zimmerman, that "it was electricity that would pass it over the wires; that it would carry the sound right along;" to Hale, that "it was driven by a magnet;" to H. K. Drawbaugh, that "the sound could be carried to a distance on a wire by the use of electricity;" to Lenig, that "electricity was used in connection with it;" to Prof. Heiges, that "in connection with a talking machine both magnetism and electricity were applied;" to Goodyear, that "his talking machine was also done by electricity over wires;" to Woods, that "it was to be an electric machine used in place of telegraphing;" to Young, that "it was an electric talking machine, which he had invented."

Thus Drawbaugh is corroborated by a cloud of witnesses whose testimony tends to substantiate his narrative.

Five hundred witnesses were examined by the parties on both sides.

Judge WALLACE, in the opinion of the Court below, after a recital of the facts and testimony from which the foregoing is taken, says: "In cases where such a chaos of oral testimony exists, it is usually found that the judgment is convinced by a few leading facts and *indicia*, outlined so clearly that they cannot be obscured by prevarication or the aberrations of memory. Such facts and *indicia* are found here; and they are so persuasive and cogent that the testimony of a myriad of witnesses cannot prevail against them."

"The proofs on both sides lead to the general conclusion that Drawbaugh was not an original inventor of the speaking telephone, but had been an experimenter without obtaining practical results until the introduction of the instruments into Harrisburg."

"Without regard to other features of the case it is suffi-

## Statement of the case.

cient to say that the defence is not established so as to remove a fair doubt of its truth, and such doubt is fatal.”

The case was argued before His Honor Judge WALLACE, by Hon. Geo. F. Edmunds and Lysander Hill, Esq., for the defendants. Judge WALLACE decided in favor of the patent, filing an opinion December 1, 1884.

All the Drawbaugh testimony had been stipulated into the Overland cases then pending. After the Drawbaugh Company had by the argument and by Judge WALLACE'S opinion, learned the grounds of his decision, they arranged with the Overland Company to take more testimony in support of Drawbaugh in the Overland suit.

By stipulation, this was put in the original Drawbaugh case, with an agreement that it should be considered by the Court. It was presented for the consideration of the Court December 2, 1885, and argued before Judge WALLACE, who thereupon affirmed his former decision, filing his opinion December 4, 1885. See the decree below, 22 Blatchf. 531, and see also 22 Fed. Rep. 309, and 25 Fed. Rep. 725.

“The chronological order of Drawbaugh's machines, as established by the evidence, is as follows :

Teacup transmitter and receiver.....	1866-1867
F and B. (Tumbler and tin can).....	1867-1869
C. (Breastwork instrument).....	1869-1870
I. (Cuspidor shape).....	1870-1871
A. With mouthpiece at centre.....	1873
A. With mouthpiece at side of centre.....	1874
D and E. (Finished Magneto-Instruments) January and February.....	1875
L. M. G. O. (Microphones.) From February, 1875, to August.....	1876
H. (The copy of the Blake transmitter.) August.....	1876
J. N. P.....	1868”

*Instrument marked H full size Sheet 1  
Harrisburg Pa. June 20<sup>th</sup> 1881.  
W. H. H. Knight.  
Del.*

*K<sup>3</sup> K<sup>3</sup> Elevation,  
L K<sup>2</sup>*

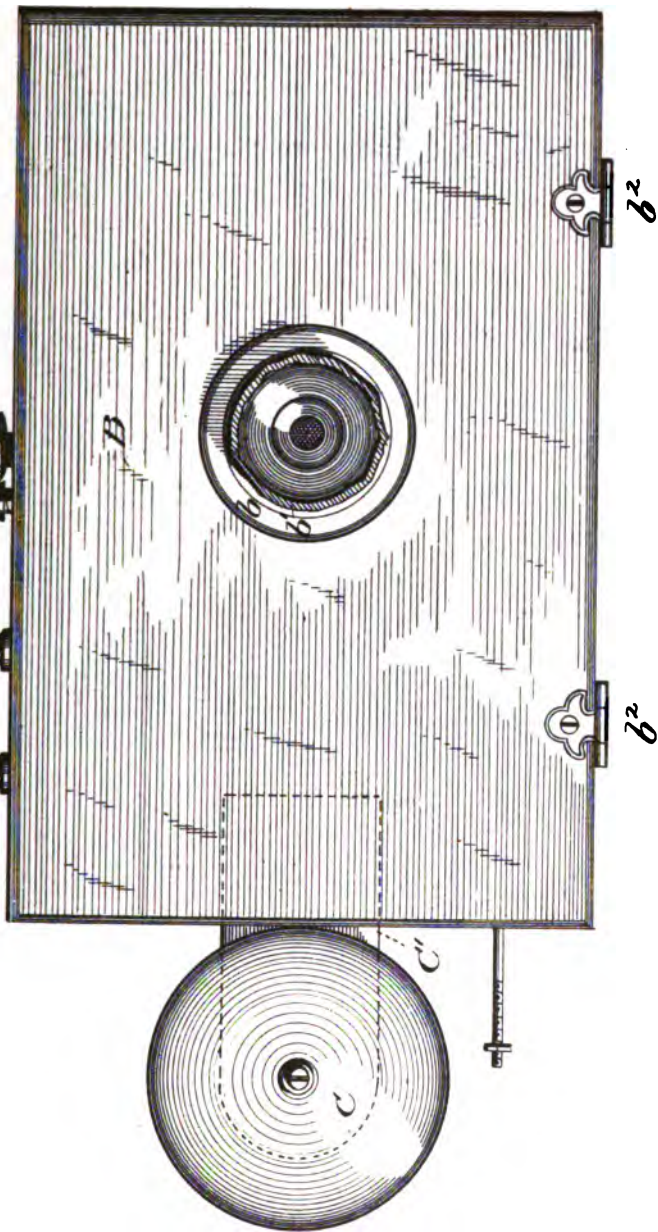

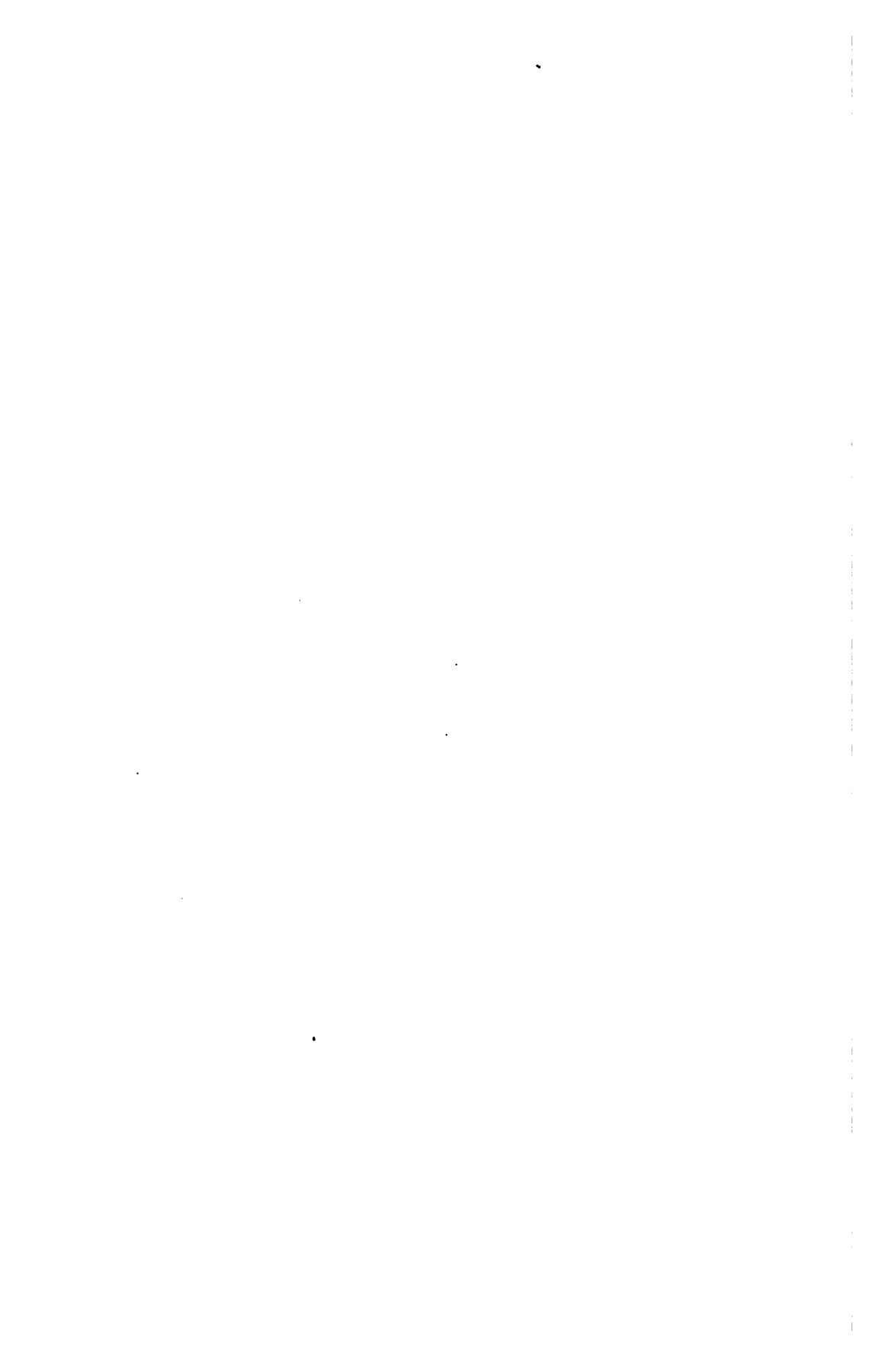

*Instrument marked X full size Skoot E.  
 Haverhill Pa. June 20th 1881.  
 Wm. H. Knight.  
 Des.*

*Front elevation. open.*

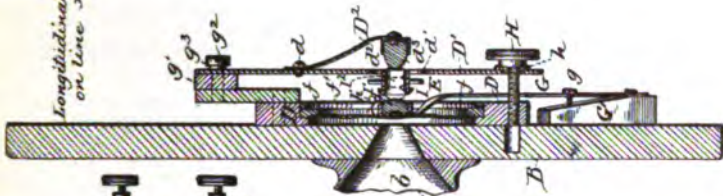
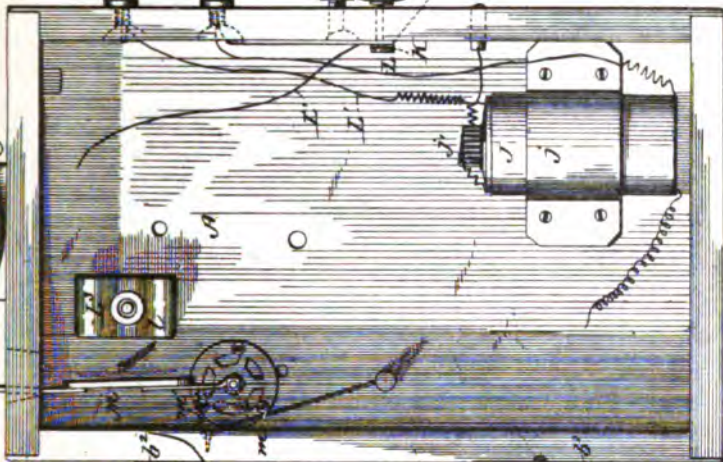
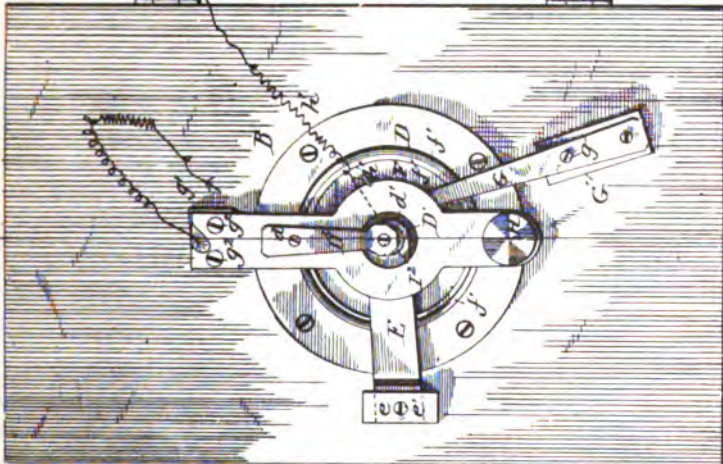

*Longitudinal section  
 on line X, X.*

X

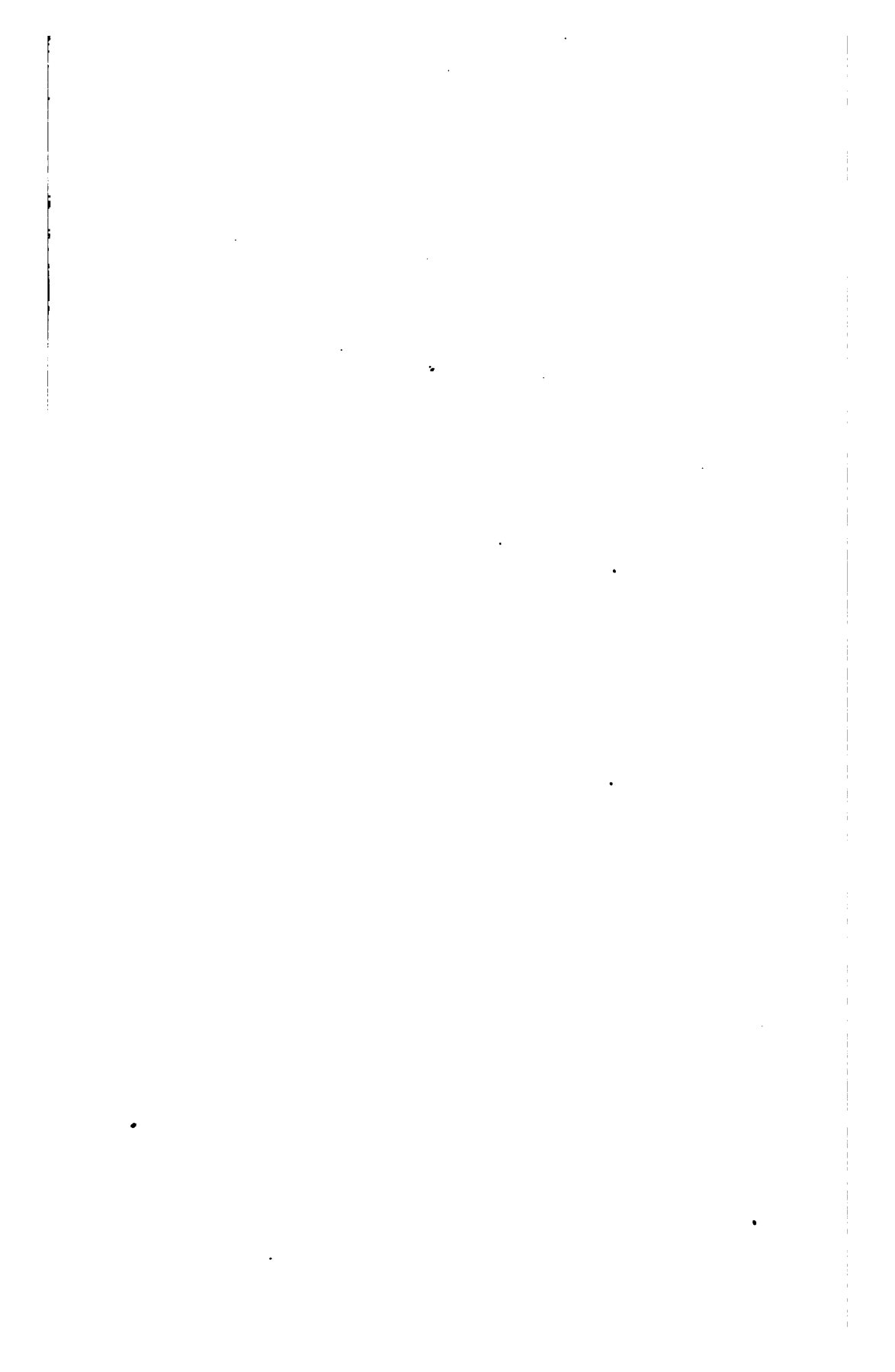

## Statement of the case.

## REFERENCES TO THE DRAWINGS OF INSTRUMENT "H."

- |  |   |
|--|---|
| <p><i>A.</i> Body of instrument.<br/> <i>B.</i> Door of instrument.<br/> <i>b.</i> Mouthpiece.<br/> <i>b'</i> Break in <i>b</i>.<br/> <i>b<sup>2</sup></i> Hinges to door.<br/> <i>C.</i> Bell to instrument.<br/> <i>C'</i> Support to bell.<br/> <i>D.</i> Casting for supporting diaphragm; iron.<br/> <i>D'</i> Plate to support contact spring.<br/> <i>D<sup>2</sup></i> Contact spring.<br/> <i>d.</i> Screw securing <i>D<sup>2</sup></i> to <i>D'</i>.<br/> <i>d'</i> Aperture through <i>D'</i>.<br/> <i>d<sup>2</sup></i> Carbon holding cup; brass.<br/> <i>d<sup>3</sup></i> Carbon block in <i>d<sup>2</sup></i>.<br/> <i>E.</i> Plate or bracket to hold intermediate carbon cup; brass.<br/> <i>e.</i> Block of wood on end of <i>E</i>.<br/> <i>e'</i> Screw securing <i>e</i> and <i>E</i> to <i>B</i>.<br/> <i>F.</i> Diaphragm; corrugated iron.<br/> <i>f.</i> Rubber ring.<br/> <i>f'</i> Wire to hold diaphragm in place.<br/> <i>G.</i> Pressure spring for diaphragm.<br/> <i>G'</i> Block to which <i>G</i> is attached.<br/> <i>g.</i> Adjusting screw to <i>G</i>.<br/> <i>g'</i> Wood insulator between <i>D</i> and <i>D'</i>.<br/> <i>g<sup>2</sup></i> Screw securing <i>D'</i> to <i>D</i>.<br/> <i>g<sup>3</sup></i> Rubber sleeve insulating <i>D'</i> from <i>g<sup>2</sup></i>.</p> | <p><i>H.</i> Adjusting screw to <i>D'</i>.<br/> <i>h.</i> Rubber sleeve insulating <i>D'</i> from <i>H</i>.<br/> <i>h'</i> Wire to diaphragm; conducting wire.<br/> <i>I.</i> Carbon holding cup.<br/> <i>I'</i> Carbon ball in <i>I</i>.<br/> <i>I<sup>2</sup></i> Intermediate carbon holding tube; wood.<br/> <i>J.</i> Induction coil.<br/> <i>j.</i> Band holding <i>J</i> in place; brass.<br/> <i>j'</i> Wire core of <i>J</i>.<br/> <i>K.</i> Signal plate.<br/> <i>K'</i> Contact spring.<br/> <i>K<sup>2</sup></i> Key.<br/> <i>K<sup>3</sup></i> Binding posts.<br/> <i>L.</i> Screw to secure switch.<br/> <i>L'</i> Conductors.<br/> <i>L<sup>2</sup></i> Switch contacts.<br/> <i>L<sup>3</sup></i> Plate to hold electro-magnets for bell in place.<br/> <i>l.</i> Bolt to plate <i>L<sup>3</sup></i>.<br/> <i>M.</i> Armature connected with bell hammer.<br/> <i>m.</i> Pivotal point of <i>M</i>.<br/> <i>m'</i> Spring to <i>M</i>.<br/> <i>N.</i> Cord to increase power of spring <i>m'</i>.</p> |
|--|---|

## THE OVERLAND CASES.

These were a number of suits brought in 1883, in New York, in New Jersey, and in Pennsylvania, against the Overland Telephone Company and various of its branches. Motions for preliminary injunctions were made in them, and were very fiercely contested through many days of argument before Judges McKENNAN, NIXON and BUTLER, and were finally granted. The cases went to final hearing on testimony, entitled in all the suits. Some of the counsel and the principal experts for the defence in the Molecular case were also counsel and experts in the Overland cases. Substantially

## Statement of the case.

the same testimony was used by stipulation in both cases, some more being added in the Overland cases after the Molecular case was decided. When these cases were reached for hearing, the Molecular case had been decided, and the Overland cases were not argued, so far as the first patent was concerned. The Court found that there was nothing to distinguish them from the Molecular case, and a decree was rendered for the complainants.

From the decree in the New York Overland case, an appeal was taken to this Court.

The following is a statement of the defences in the People's or Drawbaugh case and in the Overland case, taken from one of the briefs filed in their behalf:

"The defences in these actions are, first, a denial of the validity of both of said patents, on the ground that Alexander Graham Bell was not the original and first inventor of any of the inventions claimed therein, constituting or applicable in connection with electric speaking telephones, but that Daniel Drawbaugh, of Eberly's Mills, otherwise known as Milltown, Cumberland county, Pennsylvania, was the original and first inventor of all such inventions and improvements described and claimed in said two patents, or in either of them.

"Secondly, a denial that either of the said Bell patents is infringed by the defendants.

"Thirdly, a denial that either of said Bell patents is valid in law.

"Fourthly, a denial that Bell had achieved the invention of the electric speaking telephone at the date of his patent of March 7, 1876.

"Fifthly, a denial that the matters described in said patent of March 7, 1876, were original with Bell; but that he derived many of them from Elisha Gray, a prior inventor of the electric speaking telephone.

"Sixthly, a denial that the matters described in Bell's



## Statement of the case.

patent of January 30, 1877, were original with Bell ; but that he derived many of them from said Gray.

“Seventhly, a denial that Bell had any right to incorporate into either of his said patents any principles, inventions, methods, or devices, knowledge of which he derived from said Gray, and that his patents have any validity, in view of the fact that he so appropriated Gray’s inventions.”

Following is the Statement of Errors relied upon by the defendants in these two cases, the People’s (Drawbaugh) and Overland cases, as taken from the briefs of their counsel :

“1. The Court below erred in holding the Bell patents in suit, or either of them, valid.

“2. It erred in holding said patents, or either of them, to have been infringed by the defendants, or any of them.

“3. It erred in holding that Daniel Drawbaugh was not the first and original inventor of the inventions here in suit.

“4. It erred in not holding Elisha Gray to have invented the electric speaking telephone, in its variable resistance method.

“5. It erred in not holding the Bell patent of March 7, 1876, here in suit, to be fraudulent and void, in view of the evidence as to fraudulent changes in the application therefor, and the fraudulent introduction of Gray’s inventions into said application, while pending in the Patent Office.

“6. It erred in not holding the Bell patent of January 30, 1877, here in suit, to be fraudulent and void, in view of the evidence as to fraudulent introduction of Elisha Gray’s said inventions into the same.

“7. It erred in not holding Bell to have surreptitiously and unjustly obtained both of said patents for that which was in fact invented by another (to wit, by Elisha Gray), who was using reasonable diligence in adapting and perfecting the same.

“8. It erred in not holding Bell to have surreptitiously and unjustly obtained both of said patents for that which was in fact invented by another (to wit, by Daniel Draw-

## Statement of the case.

baugh), who was using reasonable diligence in adapting and perfecting the same in his various improved instruments.

"9. It erred in not dismissing the appellees' bill for want of equity and right, in view of the frauds shown by the appellees' own evidence to have been perpetrated upon the Patent Office, Elisha Gray, and the public in the procurement of the patents, and remaining in the patents, on which said bill is founded.

"10. It erred in construing said patent of March 7, 1876, here in suit, to cover anything more than a magneto-electric current generated by the vibration, by sound-waves, of a body of inductive material in the presence of a body susceptible of receiving induction therefrom; and it further erred in not holding such a patent for a current to be a patent for an 'effect,' 'mode of operation' or 'principle,' and therefore void.

"11. It erred in not holding said patent of March 7, 1876, to be limited to the described apparatus of its figure 7—there being, as the appellees contend, no 'art' then known, and there being no equivalents for this apparatus described in the specification.

"12. It erred in not holding said patent of January 30, 1877, to be invalid and void, by reason of its claiming matters described and shown, but not claimed in Bell's prior patent of March 7, 1876, the application not having been filed till after the former patent was issued, and said matters not having been reserved in said prior patent as matters to be afterwards applied for, but having been abandoned to the public by describing and showing without claiming them, in said prior patent.

"13. It erred in not limiting the scope of the claims of the patent of January 30, 1877, here in suit, to mere improvements in the form of the parts mentioned in said claims.

"14. It erred in holding that the specification of Bell's patent of March 7, 1876, describes the speaking telephone invention with the clearness, fullness, and exactness which

## Statement of the case.

the statute requires in such cases ; and that the patent is not invalid for want of a proper description and specification of said alleged invention.

"15. It erred in holding that Bell, in the sense of the patent law, completed or made any invention of an electric speaking telephone before a date later than March 7, 1876, and, therefore, in not holding the patent void, as being for an invention not made, at or prior to its date, by the patentee.

"16. It erred, throughout its opinion in the case against the People's Telephone Company, in treating the evidence as to Drawbaugh's priority of invention, by ignoring, misconstruing, misstating, and misunderstanding the evidence ; by assuming things of which there was no evidence, or which were contrary to the evidence ; by misunderstanding and misapplying the law ; and by attributing different degrees of probative force to the same kinds of evidence accordingly as it found the same on the one side or on the other side of the case."

There are certain questions common to all these cases. The meaning and construction of the Bell patent and understanding of what the speaking telephone is ; the comparison of the invention set forth in the Bell patent with the previous state of the art, and particularly with what is known as the Reis telephone ; the question of the meaning and scope of Mr. Bell's claims on which the issue of infringement turns, and some questions sought to be raised upon his history and work—were subjects of discussion in all these cases.

The burden of the controversy turns on the first patent. Its language is criticised.

The attempt is made to narrow the legal effect of the claim, on the ground that it is broader than the law allows to any inventor.

It is contended that at the time of the Bell patent such electrical knowledge existed, and the state of the art was such that it required no invention to make electric speaking telephones.

## Statement of the case.

It is alleged that, before Mr. Bell, certain named persons had invented the electric speaking telephone.

Except in the case of one alleged prior inventor,—the Pennsylvania claimant, Drawbaugh,—the controversy chiefly turns upon a comparison of Mr. Bell's speaking telephone with the previous state of the art.

## EXTRACTS FROM THE ANSWER OF THE MOLECULAR TELPHONE COMPANY.

10. This defendant, further answering said bill, denies that the said Bell patent No. 174,465, dated March 7, 1876, is valid, and alleges that it is invalid and void for the following reasons, to wit:

(a.) Because the instrument or machine shown, described and claimed therein is not a patentable invention, but an in-operative, useless, and worthless device.

(b.) Because the said Alexander Graham Bell was not the original and first inventor or discoverer of the thing patented in said letters patent, or of any material or substantial part thereof, but that long prior to his said alleged invention and discovery in telegraphy the same or substantially the same thing or things had been invented, discovered and used in public by, and were known to, the following named persons and at the following named places, to wit:

Philip Reis, then of Friedrichsdorf, Germany, now dead, at Friedrichsdorf and Frankfort, Germany.

Elisha Gray, of Highland Park, Ill., at Oberlin and Cleveland, Ohio; Highland Park and Chicago, Ill.; Milwaukee, Wis.; Washington, D. C., and New York City.

Thomas A. Edison, of Menlo Park, N. J., at Menlo Park, N. J., and New York City.

Daniel Drawbaugh, of and at Eberly's Mills, in the county of Cumberland and State of Pennsylvania.

Amos E. Dolbear, of Somerville, Mass., at Somerville, Mass., and elsewhere in the United States.

Alfred G. Holcomb, of Granby, Conn., at New York City, N. Y., and elsewhere in the United States.

## Statement of the case.

Philip H. Van der Weyde, of Brooklyn, at New York City, N. Y., and elsewhere in the United States.

James W. McDonough, of Chicago, Ill., at said Chicago; at New York City, and elsewhere.

W. F. Channing, of Providence, R. I., at Providence, R. I.

Benjamin F. Edwards, now deceased, formerly of Boston, Mass., at Boston, Mass.; Washington, D. C., and New York City, N. Y.

James Hamblet, Jr., of Brooklyn, N. Y., at Boston, Mass.; Washington, D. C., and New York City.

Edward Farran, of Keene, N. H., at Keene, N. H.

Antonio Mencia, of Clifton, Staten Island, N. Y., at Staten Island and New York City.

W. S. Voelker, of Morton, Delaware county, Pa., at Philadelphia, Pa.; Morton, Delaware county, Pa., and other places in the United States.

Edward C. Pickering, of Cambridge, Mass., at Boston, and Cambridge, Mass.; and also by numerous other persons whose names and residences are now unknown to these defendants, but which, when known, these defendants pray leave, by proper amendments, to insert in this answer.

\* \* \* \* \*

(j.) Because, as defendants are informed and believe, long prior to any invention by said Bell of the alleged improvement specified as his invention in said letters patent, No. 14,465, the same was described in and patented by the following letters patent, viz.:

Letters patent granted by the United States to Thomas A. Edison and George Harrington, dated August 12, 1873, No. 141,777.

Letters patent of the United States granted to William Thompson, dated November 17, 1874, No. 156,897.

Letters patent of the United States granted to Elisha Gray, July 27, 1875, No. 166,096.

Letters patent of the United States granted to Elisha Gray, July 27, 1875, No. 166,094.

## Statement of the case.

Letters patent of the United States granted to Elisha Gray, July 27, 1875, No. 166,095; caveat filed by Elisha Gray in the United States Patent Office February 14, 1876.

Letters patent of the United States granted to Elisha Gray, April 11, 1876, No. 175,971.

Letters patent of the United States granted to Elisha Gray, January 16, 1877, No. 186,340.

British letters patent granted to C. F. Varley, 1870, No. 1,044.

British letters patent granted to J. H. Johnston, July 29, 1874, No. 2,646.

British letters patent granted to George T. Bousfield, dated May 4, 1876, No. 1,874.

French patent granted to Leon Scott, dated March 25, 1857; certificate of addition to same dated July 29, 1859.

British letters patent granted to John Henry Johnston, dated March 16, 1875, No. 974.

British letters patent granted to Charles Wheatstone, dated January 21, 1840, No. 8,345.

British letters patent granted to David Hughes, dated April 27, 1858, No. 938.

United States letters patent granted to Elisha Gray, dated February 15, 1876, No. 173,460.

Also in other letters patent which are now unknown to these defendants, but which, when known, these defendants pray leave by proper amendments to insert in this answer.

(k.) Because long before any invention or discovery by said Bell of the alleged improvement specified as his inventions in said letters patent No. 174,465, the same was described in the following printed publications:

“Electricity and Magnetism,” by Jenkins, a book printed and published in London, England, and in the City of New York, in the year 1873, at p. 334.

“Der Electromagnetische Telegraph,” by H. Schellen, a printed book published in Brunswick, Germany, in the year 1867, at pp. 468 and 469.

## Statement of the case.

"The Electric Telegraph," by R. Sabine, a book printed and published in London, England, 1867, at pp. 164, 165, 166, and 167.

"L'Eco d'Italia," 1860.

"Lehrbuch der Technischen Physik," by Hassler Pisko, a book published at Vienna, 1866, Vol. 1, p. 648.

Also in a printed publication in the German language, entitled "Jahresbericht des Physikalischen Vereins zu Frankfurt am Main," a book printed and published in 1862, and particularly at pp. 57-64.

A printed publication in the German language entitled "Zeitschrift des Deutsch-Oesterreichischen Telegraphen-Vereins," Vol. 9, a book printed and published at Berlin, in 1862, particularly at pp. 125-130.

A printed publication in the German language entitled "Die Neueren Apparate der Akustik," von Dr. Prof. Fr. Jos. Pisco, printed and published in 1865, particularly at pp. 96-103 and pp. 241 and 242.

Yearly report of the Physical Society at Frankfurt-a-M., 1860, 1861, at p. 57, etc.

A French publication entitled "Petit Traité de Physique," par M. J. Jamin, Paris, 1870, and particularly at p. 421.

The "Telegraphic Journal," published in London, in the year 1872, Vol. 1, at p. 4.

"Electricity," by R. M. Ferguson, a printed book, published in London and Edinburgh in 1867, at pp. 257 and 258.

"The Telegrapher," published in the city of New York in 1869, Vol. 5, No. 39, at pp.

"The Manufacturer and Builder" for May, 1869, a newspaper published in the city of New York, in 1869, Vol. 1, at p. 129.

"Wonders of Electricity," by J. Baile, published in New York City in 1872, at pp. 140, 141, 142 and 143.

"The Telegraphic Journal," published in London in the year 1875, Vol. 3, at pp. 286, 287 and 288.

## Statement of the case.

"Dingler's Polytechnic Journal" for 1863, Vol. 163, pp. 23 and 185, a book published at Leipsic in 1863.

"Cosmos" for 1864, Vol. 24, pp. 349, 352, a printed book published in Paris in 1864, article by M. St. Edmé.

"Description Reis Telephone, König's Catalogue of Apparatus for 1865," a book printed and published in Paris.

"Applications de l'Électricité" by Du Moncell, Vol. 2, p. 255, etc., a printed book published in Paris in 1854. (Bourseul Apparatus.)

"L'Année Scientifique," by Louis Figuier, 1858, Vol. 1, p. 62, a book printed and published at Paris, France, in 1858.

"Cosmos," by l'Abbé Moigno, 1859, eighth year, Vol. 14, No. 11; article about the "Scott Phonograph;" a book printed and published in Paris in 1859.

"Traité Elementaire de Physique," by M. Ganot; eleventh edition, 1854, p. 224; a book published in Paris in 1854; article "Scott Phonograph."

"Comptes Rendus de l'Académie des Sciences," Vol. 53, p. 108, 1861.

"Poggendorf Annalen," 1843, Vol. 59, p. 177, a book printed and published at Leipsic, 1843.

"Didaskalia," a journal published in Frankfort-on-the-Main, September 28, 1854, No. 232, and on May 11, 1862, No. 130, and on May 14, 1862, No. 133.

"Du Moncel's Exposé des Applications de l'Électricité," a book published in Paris, France, in 1856, p. 246, and in 1857, p. 110.

"Frankfurter Conversationsblatt," a journal published in Frankfort-on-the-Main, November 29, 1861, and June 30, 1863.

"Die Fortschritte der Physik," a journal published in Berlin, pp. 171, 173, and in 1863, p. 96.

"Aus der Natur," published in Leipsic, 1862, Vol. 21, pp. 470, 471 to p. 484.

"Müller Poillet's Lehrbuch der Physik und Meteorologie,"



## Statement of the case.

published in 1862 in Germany, and in 1863, Vol. 2, p. 352, Fig. 325, and 1868, pp. 386, 388, Figs. 348-350.

"Friederichsdorf Zeitung," a journal published in Homberg in 1862, and also that of 1867 and 1868, pp. 386, 387, 388, 389.

"Jahresbericht des Physikalischen Vereins," Vol. 4, pp. 129 to 135, annual report for 1860, 1861, published in 1863, in Frankfort-on-the-Main.

"Böttger's Polytechnisches Notizblatt," Nos. 1-24 inclusive, pp. 65, 81-255, published in 1863.

"Deutsche Klinik," No. 48, pp. 468, 469, published in 1863 in Berlin.

"Deutsche Industrie Zeitung," published in 1863, in Chemnitz, pp. 184-208, 239 and 249.

"Die Gartenlaube," published at Leipsic, 1863, pp. 807-809.

"Prospectus of Philip Reis," published in 1863, in Frankfort, and in "Pisko's Die Neueren Apparate der Akustik," published in Vienna in 1863.

A further circular, or addition to the preceding, published in Frankfort in 1863.

The two were published with the circular or prospectus of J. Wilh. Albert, mechanic in Frankfort, in 1863.

"Polytechnisches Centralblatt," published in 1863, pp. 857, 858.

Letter of Philip Reis to W. Ladd, August 13, 1863.

"Tagesblatt der 39 Versammlung Deutscher Naturforscher," published in Giessen, in September, 1864.

"Zöllner's Buch der Erfindungen," published in Leipsic and Berlin, in 1865 and in 1872.

"Von Karl Kuhn's Handbuch der Angewandten Elektrizitätslehre," pp. 1021-1026, published in 1866.

"Albert's Catalogue," in 1866 and 1872 and 1873.

"Kneeland's Annual of Scientific Discovery," in 1866 and 1867.

"New York Tribune," January 8, 1869.

## Statement of the case.

- “Christian Union,” New York, December 25, 1875.  
 “Scientific American,” New York, March 4, 1876.  
 “Scientific American ” (supplement), February 5, 1876.  
 “Scientific American ” (supplement), No. 48, 1876.  
 “Electricity and Magnetism,” by Jenkins, in London, 1876.  
 “Journal of the Franklin Institute of the State of Pennsylvania,” Vol. 42, published in Philadelphia in 1869, pp-419 *et seq.*  
 “The Manufacturer and Builder,” April, 1870.  
 “Dublin Medical Press,” 1863, Vol. 50, No. 1,293, p. 471.  
 “Cosmos,” 1863, Vol. 23, p. 705.  
 “Zeitschrift des Architectur und Ingenieur Vereins,” 1866, Vol. 12. p. 147.  
 “The Electric Telegraph,” by Dr. Lardner, new edition, revised by E. B. Bright, published in London, England, in 1867, at pp. 164, 165, 166 and 167.  
 “Transactions Royal Scottish Society of Arts,” Edinburgh, Vol. 6, 1864, Appendix Q, pp. 184-187.  
 “Annual Report of American Association for the Advancement of Science,” for 1869.  
 “Knight’s American Mechanical Dictionary,” 1876, Article, Telephone.

\* \* \* \* \*

11. And these defendants, further answering said bill, deny that the said second Bell patent, No. 186,787, is valid, but upon information and belief allege that it is invalid and void for the following reasons, to wit:—

(a.) Because the machine and instrument shown, described and claimed therein is not a patentable invention, but is an inoperative, useless and worthless device.

(b.) Because the said Alexander Graham Bell was not the original and first inventor or discoverer of any material or substantial part of the thing patented, but before his alleged invention or discovery thereof, the same or substantially the same thing or things had been invented and used by, and

## Statement of the case.

were known to the following named persons, of and at the following named places, to wit:

[Here follow substantial repetitions of the foregoing lists.]

(c.) Because in view of the state of the art at the time of the alleged invention of said Bell the claims of said patent are too broad, covering inventions before made by others, and of which he was not, and his assigns are not, entitled to the exclusive use and enjoyment.

(d.) Because the said Bell, in obtaining said patent, surreptitiously and unjustly obtained a patent for that which was in fact invented by another, to wit, Elisha Gray, who was using reasonable diligence in adapting and perfecting the same.

(e.) Because the said Bell, in obtaining said letters patent, surreptitiously and unjustly obtained a patent for that which was in fact invented by another, to wit, said Thomas A. Edison, who was using reasonable diligence in adapting and perfecting the same.

(f.) Because the said Bell, in obtaining said patent, surreptitiously and unjustly obtained a patent for that which was in fact invented by another, to wit, said Daniel Drawbaugh, who was using reasonable diligence in adapting and perfecting the same.

(g.) Because the said Bell, in obtaining said patent, surreptitiously and unjustly obtained a patent for that which was in fact invented by another, to wit, said James W. McDonough, who was using reasonable diligence in adapting and perfecting the same.

(h.) Because if said Bell ever had any right to a patent for the alleged improvement specified as his invention in said letters patent No. 186,787, or any right to have the same secured by letters patent, he abandoned and forfeited the same, and lost all such right by his delay in applying for letters patent, and by the same having been put into public use and

## Statement of the case.

on sale more than two years before his application for a patent therefor.

(i.) Because the specification of said letters patent No. 186,787 does not sufficiently describe the things attempted to be covered by the claims thereof to enable persons skilled in the art or science to which it appertains, or with which it is most nearly connected, to make, construct and use the same; and that the alleged improvement attempted to be patented in said letters patent did not involve or require invention, and did not differ in any patentable respect from what was before said alleged invention known and used in this country or described in patents and printed publications.

(j.) Because there is no mechanical combination between the elements constituting the 6th claim of said letters patent No. 186,787, and no invention was required to produce the same.

(k.) Because long before any invention of said Bell of the alleged improvement specified as his invention in said letters patent No. 186,787, the same was described in and patented by the following letters patent, viz.: letters patent of the United States granted to Elisha Gray, July 27, 1875, No. 166,095; letters patent of the United States granted to Elisha Gray, April 11, 1876, No. 175,971; letters patent of the United States granted to A. G. Holcomb, May 16, 1860.

British letters patent granted to J. H. Johnston, July 29, 1874, No. 2,646.

Letters patent granted by the Patent Office of the Dominion of Canada in 1875 to Elisha Gray, July 7, 1875, No. 4,749.

British letters patent granted to J. H. Johnston, March 16, 1875, No. 974.

British letters patent granted to George T. Bousfield, May 4, 1876, No. 1,874.

Letters patent of the United States granted to said Elisha Gray, July 20, 1875, No. 165,728.

## Statement of the case.

Letters patent of the United States granted to said Elisha Gray, February 15, 1876, No. 173,460.

Letters patent of the United States granted to said Elisha Gray, February 15, 1876, No. 173,618.

Letters patent of the United States granted to said Elisha Gray, January 16, 1877, No. 186,340.

Letters patent of the United States granted to said Bell, March 7, 1876, No. 174,465.

And also other letters patent, which are now unknown to these defendants, but which, when known, they pray leave by proper amendments to insert in this answer.

(L.) Because long before any invention by said Bell of the alleged improvement specified as his invention in said letters patent No. 186,787, the same was described in the following printed publications, viz:—

“Der Electromagnetische Telegraph,” by Dr. H. Schellen, published at Brunswick, Germany, in the year 1867, at pp. 411, 412, 413, 414, 429, 430, 431, 432, 433, 434, 435, 436, 437, 438, 468 and 469.

“Zeitschrift des Deutsch-Oesterreichischen Telegraphen-Vereins,” published at Berlin, Prussia, in the year 1862, Vol. 9, p. 125.

Yearly report of the Physical Society at Frankfurt-a-M., 1860, 1861, p. 67, etc.

“Die Neueren Apparate der Akustik,” von Dr. Prof. Jos. Pisko, printed and published in 1865.

“Journal of the German-Austrian Telegraph Association,” Vol. 9, p. 125, 1862, and pp. 94–104.

“The Electric Telegraph,” by R. Sabine, published in London, England, in 1867, at pp. 136, 137 and 138.

“The Telegraphic Journal,” published in London, in 1872, Vol. 1, p. 4.

“Electricity,” by R. M. Ferguson, published in London and Edinburgh, in the year 1867, at pp. 257 and 258.

“The Telegrapher,” published in the city of New York, in the year 1869, Vol. 5, No. 89, at p.

## Statement of the case.

“The Manufacturer and Builder,” published in the city of New York, in the year 1869, Vol. 1, at p. 129.

Similar allegations and lists appear in the answers of the Overland and Clay Commercial Companies.

## PUBLICATIONS RELATING TO BOURSEUL.

*L'Illustration, Journal Universal, Paris, August 26, 1854, Vol. XXIV., No. 600, p. 139.*

## BOURSEUL'S COMMUNIOATION.

“The electric telegraph is based on the following principle: An electric current, passing through a metallic wire, circulates through a coil around a piece of soft iron which it converts into a magnet. The moment the current stops, the piece of iron ceases to be a magnet. This magnet, which takes the name of electro-magnet, can thus in turn attract and then release a movable plate (*plaque mobile*) which, by its to-and-fro movement, produces the conventional signals employed in telegraphy. Sometimes this movement is directly utilized, and is made to produce dots or dashes on a strip of paper which is drawn along by clockwork. The conventional signals are thus formed by a combination of those dots and dashes. This is the American telegraph which bears the name of Morse, its inventor. Sometimes this to-and-fro movement is converted into a movement of rotation. In that way we have either the dial telegraph used on railroads, or the telegraph used in the government system, which by means of two line-wires and two indicating needles reproduce all the signals of the aerial telegraph or semaphore which was formerly used. Suppose, now, that we arrange upon a movable horizontal circle, letters, figures, signs of punctuation, etc. One can understand that the principle we have stated can be used to choose at a distance such and such a character, and to determine its movement, and conse-

## Statement of the case,

quently to print it on a sheet of paper appropriately placed for this purpose. This is the printing telegraph.

“ We have gone still further. By the employment of the same principle, and by means of a mechanism rather complicated, it has been possible to reach a result which at first would seem to be almost a miracle. Handwriting itself is produced at a distance, and not only handwriting, but any line or any curve; so that, being in Paris, you can draw a profile by ordinary means there, and the same profile draws itself at the same time at Frankfort. Attempts of this sort have succeeded. The apparatus has been exhibited at the London exhibition. Some details, however, remain to be perfected. It would seem impossible to go beyond this in the region of the marvelous. Let us try, nevertheless, to go a few steps further. I have asked myself, for example, if the spoken word itself could not be transmitted by electricity; in a word, if what was spoken in Vienna may not be heard in Paris? The thing is practicable in this way:

“ We know that sounds are made by vibrations, and are made sensible to the ear by the same vibrations, which are reproduced by the intervening medium. But the intensity of the vibrations diminishes very rapidly with the distance; so that even with the aid of speaking tubes and trumpets it is impossible to exceed somewhat narrow limits. Suppose that a man speaks near a movable disc, sufficiently flexible to lose none of the vibrations of the voice; that this disc alternately makes and breaks the connection with a battery; you may have at a distance another disc which will simultaneously execute the same vibrations.

“ It is true that the intensity of the sounds produced will be variable at the point of departure, at which the disc vibrates by means of the voice, and constant at the point of arrival, where it vibrates by means of electricity; but it has been shown that this does not change the sounds. It is, moreover evident that the sounds will be reproduced at the same pitch.

## Statement of the case.

“The present state of acoustic science does not permit us to declare *a priori* if this will be precisely the case with syllables uttered by the human voice. The mode in which these syllables are produced has not yet been sufficiently investigated. It is true that we know that some are uttered by the teeth, others by the lips, etc.; but that is all.

“However this may be, observe that the syllables can only reproduce upon the sense of hearing the vibrations of the intervening medium. Reproduce precisely these vibrations, and you will reproduce precisely these syllables.

“It is, at all events, impossible, in the present condition of science, to prove the impossibility of transmitting sound by electricity. Everything tends to show, on the contrary, that there is such a possibility. When the application of electro-magnetism to the transmission of messages was first discussed, a man of great scientific attainments treated the idea as utopian; and yet there is now direct communication between London and Vienna by means of a simple wire. Men declared it to be impossible, but it is done.

“It need not be said that numerous applications of the highest importance will immediately arise from the transmission of speech by electricity. Any one who is not deaf and dumb may use this mode of transmission, which would require no apparatus except an electric battery, two vibrating discs and a wire. In many cases, as, for example, in large establishments, orders might be transmitted in this way, although transmission in this way will not be used while it is necessary to transmit letter by letter, and to make use of telegraphs which require use and apprenticeship. However this may be, it is certain that in a more or less distant future, speech will be transmitted by electricity. I have made some experiments in this direction. They are delicate, and demand time and patience; but the approximations obtained promise a favorable result.

“CHARLES BOURSEUL.

“PARIS, August 18, 1854.”



## Statement of the case.

*Didaskalia, Blätter für Geist, Gemüth und Publicität.*

Frankfort-on-the-Main, Germany, No. 232, September-28,  
1854.

(Magazine for Intelligence, Humor and News.)

“The wonders with which electricity has lately astonished us are about, as it seems, to be increased by a new one, that would not only prepare a great revolution in the electric telegraph as practiced up to the present, but would increase its usefulness in an incalculable manner.

“It is a question of nothing more nor less than an electric transmission of *the spoken word*. The idea originates with a young and educated, though modest young man, Charles Bourseul, who was a soldier of the African army in 1848, where he attracted the attention of the governor-general by a mathematical course which he delivered to his comrades of the garrison in Algeria, and he is now living in Paris. Bourseul’s problem, of the practicability of which he is completely persuaded, belongs, perhaps, to those discoveries which the scientific world afterwards declares very easy, and which they would gladly make us believe could easily have been discovered much earlier if they had chosen to give themselves the trouble.

“As is well known, the principle upon which electric telegraphy is based is as follows: An electric current traversing a metallic wire changes a piece of soft iron in the vicinity of which it passes into a magnet. As soon as the current ceases, the magnetic quality also ceases. This magnet, the electro-magnet, can thus alternately attract or let go a movable plate, which, by its movements back and forth, produces the conventional signals used in telegraphy. Now, it is farther known that all tones are brought to the ear only by vibrations of the air; hence are really nothing more than these vibrations of the air, and that the endless variety of tones depends entirely upon the rapidity and amplitude of the sound-waves. Could there now be invented

## Statement of the case.

a metallic plate which should be so movable and pliable that it reproduces all the vibrations of tones (like the air), and should this plate be so connected with an electric current that it should alternately make and break the electric current according to the air vibrations by which it was affected, it would thereby be possible also to arrange electrically a second similarly constructed metal plate, so that it repeated simultaneously exactly the same vibrations as the first plate, and it would then be exactly the same as if one had spoken in the immediate vicinity against this second plate, or the ear would be affected precisely as if it received the tones directly through the first metallic wall. The electric telegraph, formerly stamped by the Academy as nonsense, is now spread throughout all the world as a common phenomenon; if we question in regard to this new idea of a young physicist the principles of physics, they have not only nothing to offer against the possibility of its being carried out, but its success appears in fact to be more probable than did a short time ago that of the electric telegraph itself. If it be practically carried out, the electric telegraph could be operated by every one. There would be need of no farther device and knowledge than a galvanic battery, two vibrating plates and a metal wire; without any other preparation the one must talk against one metallic plate, and the other hold his ear near the other plate, and they could converse with each other as if face to face. The young inventor believes in the success of his efforts, and challenges scientific men to prove that the laws of physics contradict the above-mentioned principles, and thereby make the attempt seem impossible. Meanwhile may the affair enjoy in high degree the attention which it is certainly attracting."

Statement of the case.

PUBLICATIONS BY REIS AND OTHERS RELATING  
TO THE REIS TELEPHONE.

REPORT OF REIS' LECTURE.

*Frankfurter Conversationsblatt, November 29, 1861.*

*Reproduction des Schalles durch den Galvanischen Strom.  
(Frankfurt.)*

(Reproduction of Sound by the Galvanic Current. Frank-  
fort.)

"For this new discovery, which rightly excites the great-  
est interest, we have to thank Mr. Reis, teacher in Fried-  
richsdorf. He has succeeded after many experiments in  
solving, up to a certain point at least, this problem, which  
up to the present has been considered insolvable.

"Of all the new discoveries in natural science there are  
none of so general advantage, and which so enter into our  
practical life, as those in the domain of chemistry and  
physics; in the latter, galvanism in its application to electro-  
plating and telegraphy has achieved remarkable results. At  
the moment when telegraphy has attained a place in our  
social life, there begins, perhaps, for the same a new era in  
the fact that as we in telegraphy make ourselves understood  
by means of signs, in this we can make ourselves understood  
by means of tones at a distance.

"Mr. Reis has constructed in a very ingenious manner an  
apparatus by means of which he has shown some perfectly  
successful experiments before a large audience in the Physi-  
cal Society in this city.

"He has made a very happy use of the earlier discovery  
that the iron core of a wire helix produces tones by the in-  
terruptions of the current following each other at very short  
periods.

"His apparatus for receiving the sound is based upon the  
arrangement of the human ear. It consists, in the first  
place, of a funnel-shaped cavity (to represent the cartilage of

## Statement of the case.

the ear) to receive the sound, closed at its narrower part by a membrane, upon which is fastened an elastic strip of platinum which is connected with one of the circuit wires, while the former is in electric connection with the other pole of the battery.

“As soon, then, as the sound-waves set the membrane in vibration, the elastic strip of metal fastened to the same will make the same vibrations—will alternately rise and fall, thereby touching the other elastic strip and so making and breaking the current.

“The reproduction of the sound by the galvanic current, for it is only such and not a conduction of the sound, is brought about in the manner specified above. Into a wire helix, included in the circuit, is placed a thin metal rod—*e. g.*, a knitting needle—which apparatus, in order to increase the tone, is placed upon an easily vibrating support, a resonant box. By means of the current now made, now broken, the iron rod is also set into vibrations, which are communicated to our ear and there reproduce the sound.

“The vibrations of the iron rod correspond with those of the membrane; but as the pitch of the tones is dependent upon the times of vibration of the sounding-body, the lower tones escape our notice, while the higher ones are especially noticed.

“Up to the present the reproduction of the tones is indeed weak, and words cannot be reproduced. We leave here the question as to whether this hereafter will be successfully accomplished.

“Mr. Fritz, instrument maker, has just constructed a new instrument with some improvements, and Prof. Böttger will hereafter make the experiments with it in the Physical Society, to which we shall at times call attention.

## Statement of the case.

## REIS LECTURE.

*Jahresbericht des Physikalischen Vereins zu Frankfurt am Main, für das Rechnungs Jahr, 1860-1861.*

(Yearly Report of the Physical Society at Frankfort-a-M., 1860-1861, pp. 57-64, published in 1862.)

*“On Telephony by means of the Galvanic Current, by Philip Reis.”*

“The extraordinary results in the field of telegraphy have probably often raised the question, if it might not be possible to transmit musical tones themselves [Tonsprache] to a distance? Experiments made in this direction could not, however, produce any results at all satisfactory, because the vibrations of sound-conducting media soon lose their intensity to such an extent that they are no longer appreciable by our senses.

“A reproduction of tones [Tönen] at certain distances by means of a galvanic current has probably been thought of, but the practical solution of this problem has certainly seemed the most doubtful to the very persons who, from their knowledge and appliances, were in the best condition to attack it. To a person having only a superficial knowledge of physics the problem presents far less difficulties, simply because the most of them are unperceived. About nine years ago I also (having an extraordinary enthusiasm for what was new, and an insufficient knowledge of physics) had the boldness to attempt the solution, but was soon forced to desist because the very first experiment convinced me of the impossibility of its solution.

“Later, after further study and experience, I came to see that my first experiment had been a very rough and by no means conclusive one; I did not, however, follow up the subject seriously, because I did not feel myself equal to the difficulties in the way.

“Youthful impressions, however, are strong, and therefore not easily effaced. I could never get rid of the thought of that first experiment and its occasion, notwithstanding all

## Statement of the case.

that reason says to the contrary, and thus, half unwillingly, this project of my youth was reviewed in hours of leisure, the difficulties and the means for overcoming them were weighed, but for the present, at least, no experiment was made.

“How indeed could a single instrument reproduce the combined effect of all the organs occupied in human speech? This was always the cardinal question; finally I got the notion of putting the question in another way.

“How is *our ear* affected by the totality of vibrations produced by the organs of speech all simultaneously active? Or, more generally—

“How are we affected by the vibrations of several simultaneously sounding bodies?

“To answer this question, we must, in the first place, understand what must happen in order that we may perceive a single tone.

“Without our ear, any tone is nothing else than a recurrent condensation and rarefaction of some body repeated at least seven or eight times in a second. If this occurs in the same medium in which we are, the membrane of the ear is at each condensation forced towards the middle ear, to be moved at the subsequent rarefaction in the opposite direction. These vibrations produce a synchronous raising and falling of the hammer upon the anvil (according to other authorities, an approach or receding of the ear-bone particles), and a similar number of tremors in the fluid of the cochlea, in which the filaments of the auditory nerve are disturbed. The greater the condensation of the sound-conducting medium at any given moment, the greater is the amplitude of vibration of the membrane and hammer, and consequently the more powerful the blow upon the anvil and the vibration of the nerves by means of the fluid.

“The office of our organs of hearing is, therefore, to transmit with certainty up to the auditory nerve every condensation and rarefaction occurring in the surrounding medium.

## Statement of the case.

But the office of the auditory nerve is to bring to our consciousness the vibrations of matter which have occurred in a given time, both as regards number and amplitude. Here, for the first time, certain combinations receive a name; here, certain vibrations are *tones* or *noises* (*Töne* oder *Misstöne*).

“What our auditory nerve perceives is, then, simply the effect of a force coming within the range of consciousness, and this force can be represented, both as to duration and magnitude, graphically by a curve.

“Let  $a b$  represent any given time, and the curve above the line condensation (+), the curve below the line rarefaction (—), then any ordinate raised from the end of any abscissa will represent the degree of condensation, at the time represented by its base, in consequence of which the drum of the ear vibrates.



“Our ear can under no circumstances appreciate more than can be represented by these curves, and this indeed is entirely sufficient to give us a clear perception of any tone [ton] or any combination of tones.

“If several tones [*Töne*] are produced at the same time, the conducting medium is subjected to the influence of several simultaneous forces, and the two following laws will hold good; if the forces act all in the same direction, the amplitude is proportional to the sum of the forces, if the forces act in opposite directions, the amplitudes are proportional to the difference of the opposing forces.

“If, for example, in the case of three tones, we draw the curve of condensation of each separately, then by a summation of the ordinates of corresponding abscissas, we can determine new ordinates and develop a new curve, which might be called the combination curve. This represents exactly what our ear perceives of the three simultaneous tones. The fact that the musician can distinguish the three tones need not sur-

## Statement of the case.

prise us any more than the fact that any one acquainted with the theory of colors can in green discover blue and yellow ; but the combination curves in plate I show that this difficulty is a slight one, for in these curves all the relations of the components successively recur. In the case of chords of more than three notes the relations are not so readily seen from the drawing, plate II., for example. In the case of such chords, however, the skilled musician also finds difficulty in recognizing the separate notes.

“Plate III. illustrates discord [Dissonanz]. Why discords impress us unpleasantly I will leave my readers to judge at this time, though I may, perhaps, return to the subject subsequently in another paper.

“From the preceding it follows:

“*First.* Every tone [Ton] and every combination of tones, on striking our ear, causes vibrations on the drum of the ear, the succession of which may be represented by a curve.

“*Second.* The succession of these vibrations alone gives us a conception (sensation) of the tone, and every alteration changes the conception (sensation).

“As soon, then, as it is possible to produce, anywhere and in any manner, vibrations whose curves shall be the same as those of any given tone or combination of tones, we shall receive the same impression as that tone or combination of tones would have produced on us.

“With the above principles as a foundation, I have succeeded in constructing an apparatus with which I am enabled to reproduce the tones of various instruments, and even to a certain extent the human voice. It is very simple, and by means of the figure will be easily understood from the following explanation:

“In the cubical block of wood *r s t u v w x* there is a conical perforation *a*, closed at one end by a membrane, *b* (pig's intestine), upon the middle of which there is cemented a conducting strip of platinum ; this is connected with the binding screw *p* [auf deren Mitte ein stromleitendes Streif-



# Umkehrungen eines Dreiklanges.

Tafel 1.

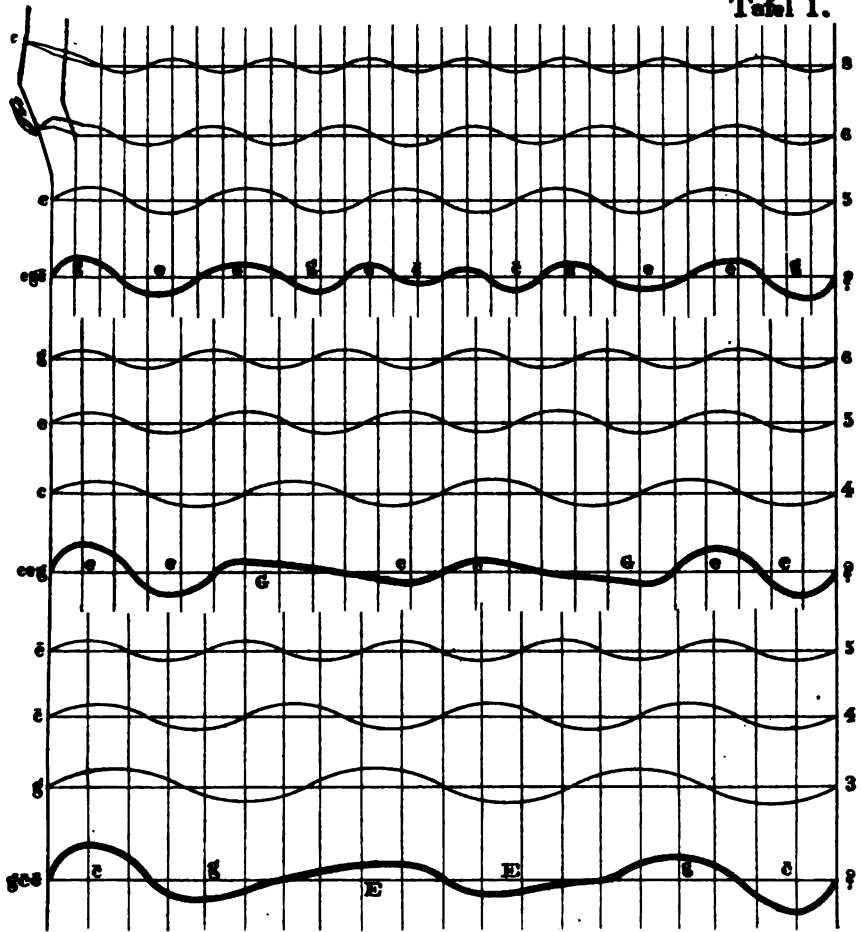



# C dur.

## Tafel II.

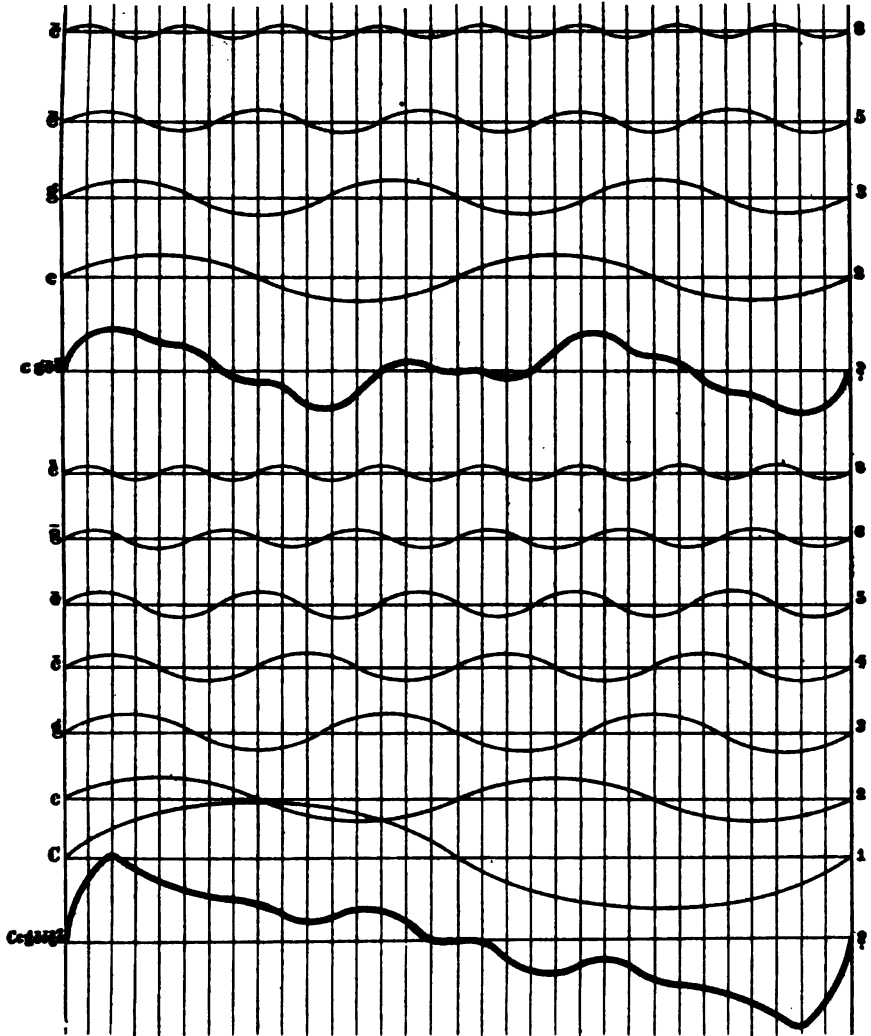



Tafel III.

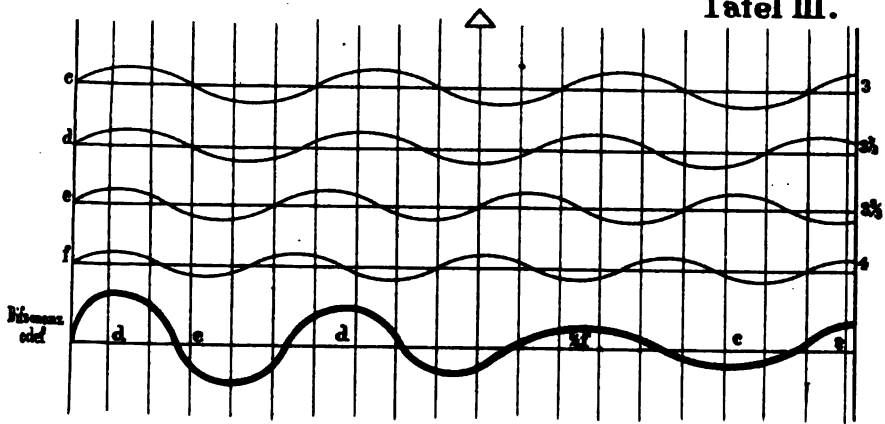



## Statement of the case.

chen, Platin festgeklittet ist. Dieses steht mit der Klemme *p* in Verbindung]. From the binding screw *n*, another thin

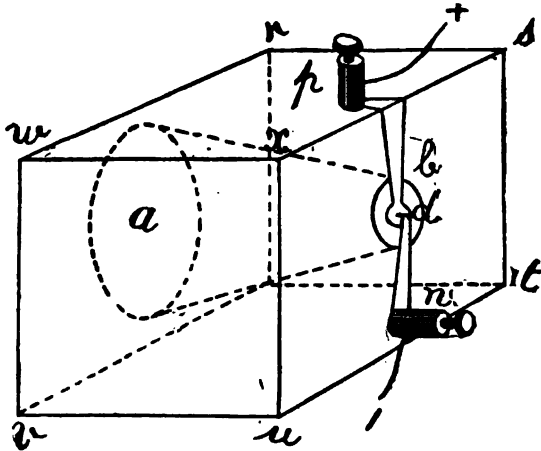

strip of metal [ein dünnes Metallstreifchen] extends until over the middle of the membrane, and ends here in a platinum wire placed at right angles to its length and surface.

“From the binding screw *p*, a conducting wire runs through the battery to a distant station, being connected with a coil of silk-covered copper wire, and this again is connected with a conductor leading back to the binding screw *n*.

“The coil at the distant station is about six inches long, is composed of six layers of fine wire, and, as a core in its centre, has a knitting needle which projects about two inches at both ends. By means of the projecting ends, the coil rests upon two bridges of a resonant case. (All this part can of course be replaced by any other apparatus by means of which the well-known ‘galvanic tones’ can be produced).

“If, now, tones or combinations of tones are produced in the neighborhood of the block, so that sufficiently powerful waves enter the opening *a*, then these sounds cause the membrane *b* to vibrate. At the first condensation the hammer-like wire *d* is pushed back; at the rarefaction it cannot follow

## Statement of the case.

the retreating membrane, and the current traversing the strips remains broken [Strom bleibt so lange unterbrochen bis, etc.], until the membrane, forced by a new condensation, again presses the strip (proceeding from  $p$ ) against  $d$ . In this way each sound wave causes a breaking and closing [ein Oeffnen und ein Schliessen] of the current [Stromes].

“At each closing [Schliessen] of the circuit [Kette] the atoms of the iron wire inside the distant spiral are moved away from each other (Pouillet Müller, p. 304, Vol. II. fifth edition); on breaking the circuit [beim Unterbrechen des Stromes] these atoms seek to regain their position of equilibrium. When this happens, in consequence of the reciprocal actions of elasticity and inertia, a number of vibrations are produced, and they give the longitudinal sound of the rod (see as above). This is the case if the making and breaking of the current [Unterbrechungen und Schliessungen des Stromes] occurs with comparative slowness. If they occur more rapidly than the oscillations of the iron core, due to its elasticity, the atoms cannot complete their course. The paths described become shorter in proportion as the interruptions are more frequent, but then are just as numerous as these.

“The iron wire no longer gives its longitudinal normal tone, but a tone whose pitch corresponds to the number of the interruptions [Unterbrechungen] (in a given time); this is the same as saying that *the rod reproduces the tone* [Ton] *impressed upon the interrupter* [dem Unterbrechungsapparat]. The intensity also of this tone is proportional to that of the original one, for in proportion as this is more intense the motions of the membrane are greater; the motions of the hammer, also, and finally the time during which the circuit remains opened, is greater, and consequently, up to a certain limit, the motions of the atoms in the reproducing wire are greater, we perceiving them as greater vibrations, in just the same way as we would have perceived the original sound-wave.



## Statement of the case.

"As the length of the conducting wire can undoubtedly be made as great as in direct telegraphy, I have called my instrument 'telephone.'

"Now, in reference to the capabilities of the telephone, it may be stated that I was enabled to render audible to the members of a large assembly (The Physical Society at Frankfort-a-M.), melodies which were sung (not very loud) into the apparatus in another house (three hundred feet away), with closed doors.

"Other experiments showed that the sounding wire was capable of reproducing complete chords of three tones of a piano, upon which the telephone was placed, and that it reproduces equally well the tones of other instruments, accordion, clarinet, horn, organ-pipes, etc., provided that the tones are within the compass F—f.

"Of course, in all experiments, sufficient precautions were taken to insure that there was no direct conduction of sound. This is very easily done by making a momentary short circuit immediately in front of the coil, by which means its action is temporarily interrupted.

"Hitherto it has not been possible to reproduce the tones of human speech [Tonsprache des Menschen] with a distinctness sufficient for every one. The consonants are for the most part reproduced pretty distinctly, but the vowels as yet not in an equal degree. The cause of this I will attempt to explain.

"According to the experiments of Willis, Helmholtz, and others, vowel tones can be produced artificially, if the vibrations of one body are from time to time augmented by those of another, somewhat as follows:—



"An elastic spring is set in vibration by the blow of a tooth on a toothed wheel; the first vibration is the greatest, and each subsequent one is smaller than the preceding.

## Statement of the case.

“If, after a few vibrations of this kind (the spring not coming to rest in the meantime), the tooth wheel imparts a new stroke, the following vibration will be again a maximum, and so on.

“The pitch of the tone produced in this way depends upon the number of vibrations in a given time, but the character of the tone upon the number of swellings [Anschwellungen] in the same time. Two vowels having the same pitch would differ in about the way represented by the curves (Figs. 1, 2), while the same tone without any vowel character would be represented by the curve (Fig. 3).

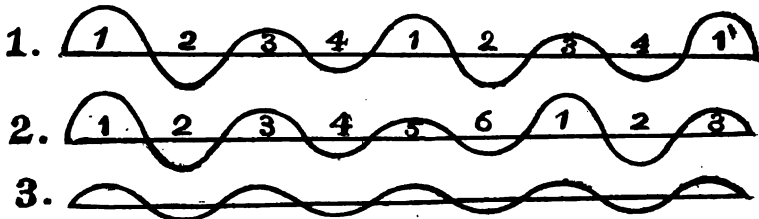

“Our organs of speech probably produce the vowels in the same manner, through the combined action of the upper and lower vocal chords, or of these latter and the cavity of the mouth.

“My apparatus reproduces the number of vibrations, but with an intensity much less than that of the original ones; though, as I have reason to believe, to a certain degree proportional among themselves. But in the case of these generally small vibrations, the difference between large and small vibrations is more difficult to perceive than in the case of the original waves, and the vowel is therefore more or less indistinct.

“Whether or not my views as to the curves corresponding to sound combinations are correct, could perhaps be decided by means of the new phonautograph of Duhamel (*Vierordt Physiology*, page 245).

“It may be that for the practical application of the telephone much remains to be done; for physics it has already

## Statement of the case.

sufficient interest, from the fact that it opens a new field for research. Friedrichsdorf, near Frankfort-a-M., December, 1861."

## REIS' EXHIBITION OF 1861.

*Fortschritte der Physik XVII., for 1861, pp. 171-3.*

Ph. Reis. *Telephony by means of the Electric Current.*

(Annual Report of the Physical Society of Frankfort-on-the-Main, 1860-1, pp. 57-64.)

"By the name 'Telephone,' the author designates the following apparatus of his own construction, by means of which and with the help of the galvanic current he is enabled 'to reproduce at a distance the tones [Töne] of different instruments and even to a certain degree the human voice.'

"A wooden cube is bored through from one of the faces to the opposite one, the cavity taking the shape of a cone; the smaller opening is closed by means of a membrane (hog's intestine, Schweinsdünndarm). On the middle of the membrane and parallel with it is a thin strip of platinum, cemented fast at one end, whilst the other end is held by a binding post [Klemme] *p*. From another binding post *q* extends a similar thin strip of metal as far as over the centre of the membrane, and carries a little platinum wire directed towards the membrane at right angles to the strip and the surface of the membrane. From binding post *p* a conductor leads through a battery to a distant coil, which again is connected by another wire to binding post *q*.

"The coil at the distant station is about six inches long, consists of about six layers of thin wire, and encloses as a core a knitting needle, which protrudes about two inches at each end. By these protruding ends the coil is supported on two bridges of a sound-board. If, now, tones or combinations of tones are produced in the vicinity of the large opening of the conical cavity so that sufficiently strong waves

## Statement of the case.

enter it, these waves will set the membrane into vibrations; by the outward motion of the membrane the platinum strip cemented on it is pressed against the hammer-shaped wire *d*, and the galvanic current [Strom] is closed [geschlossen]; by the inward motion of the membrane the current is re-opened. The alternate magnetizings and demagnetizings of the core of the coil resulting therefrom will bring forth, if the alternation is slow, the longitudinal tone of the core, and if the alternation [Aufeinanderfolge] is quicker, a longitudinal vibration of the same, the period of which corresponds to the period of the interruptions of the current [Unterbrechungen des Stromes] or of the vibrations of the membrane, and consequently to the rate or pitch of the tone which entered the conical cavity. That means, according to the author, that 'The rod [Stab] reproduces the tone which was impressed upon the interrupting apparatus [Unterbrechungsapparat].' 'The strength of this tone is also proportionate to the original tone, for,' as the author, though not very accurately, explains: 'The stronger this is the greater the motion of the little hammer, the greater finally the time during which the circuit remains open, and consequently the greater, up to a certain limit, the motion of the atoms in the reproducing rod, which motions affect us as greater vibrations, as the original wave itself would have done.' By means of this telephone the author made audible to the members of a large meeting of the Physical Society in Frankfort-a-M., melodies sung not very loud into the apparatus, in a house situated about three hundred feet distant, with closed doors.

"Other trials showed that the resounding rod is capable of reproducing full chords [Dreiklänge] of a piano on which the telephone rests, and that, in short, it reproduces just as well the tones of other instruments, such as the harmonica, clarinet, horn, organ pipe, etc., provided the tones are within a certain range, from *F* to *f*<sup>2</sup> or thereabout.

"As a matter of course, sufficient care was taken to ascertain whether direct transmission of the sounds had not a

## Statement of the case.

share in the result. This was ascertained very simply by establishing for a given time a good shunt circuit directly before the coil, in consequence of which, of course, the activity of the latter ceased for that time.

“It was not possible thus far to reproduce spoken tones [Tonsprache des Menschen] with a distinctness satisfactory to all; the consonants are for the most part distinctly reproduced, the vowels not in the same degree. The author attempts to explain this imperfect reproduction of the vowels by saying that the apparatus reproduces the vibrations to a certain extent, indeed, with proportionate, but also reduced, strength, and the ear can no longer satisfactorily discern the relation of the proportionately great vibrations, which determine the pitch [Tonhöhe], to the small vibrations on which vocal quality [vocal Farbe] depends.”

## REIS-LEGAT ARTICLE.

*Zeitschrift des Deutsch-Oesterreichischen Telegraphen-Vereins, Berlin, 1862, Vol. IX, p. 125.*

(Journal of the German-Austrian Telegraph Association, V. 9, p. 125, 1862.)

*Concerning the reproduction of sounds by means of galvanic electricity; by V. Legat, Royal Prussian Telegraph Inspector at Cassel, accompanied by copper plates VIII. and IX.*

“It might not be uninteresting to make known, in wider circles, the following ideas lately communicated by Mr. Philip Reis to the Society of Physics, and to the meetings of the Free German Institute, at Frankfort-on-the-Main, concerning the reproduction of tones [Tönen] by means of galvanic electricity, and, also, what has been hitherto accomplished towards the realization of this project, in order that the accumulated experiments may serve as a foundation to build upon, and that the capacity of the electric current, which by human ingenuity has already been made serviceable for correspondence, may be developed in this direction also.

## Statement of the case.

“In this essay we shall not deal with the electric current as to its capacity for operating telegraphic apparatus of whatever construction for the reproduction of *visible* signs, but of the application of this current to the production of *audible* signals, of *tones* [Tönen].

“The air waves, which by acting upon the ear excite in us the sensation of sound by primarily setting the tympanum of the ear into vibratory motion, are, as is well known, transmitted to the interior parts of the ear and to the auditory nerves there located by means of a lever apparatus of wonderful delicacy, the auditory bones (hammer, anvil, stirrup); and the attempt to reproduce tones therefore depends upon this; to actuate an artificial imitation of this lever apparatus by means of the vibrations of a membrane corresponding to the membrane of the ear drum, and thereby to open and close [zum Oeffnen u. Schliessen] a galvanic circuit, connected with a distant station by a metallic conductor.

“Before describing the apparatus to be used, it would be proper to inquire how our ear apprehends the vibrations of any one particular tone, and the combined vibrations of all simultaneous tones acting upon it, because thereby we may determine the operations which are to be performed by the transmitting and receiving apparatus in the solution of the problem.

“Examining first the processes which take place in order that the human ear may apprehend any single tone, we find that each tone is the result of alternate rarefactions and condensations repeated within a fixed time. If this operation occurs in the same medium in which the ear is placéd, then at each condensation the membrane is forced toward the cavity of the drum, and toward the opposite side at each rarefaction.

“These vibrations cause corresponding movements in the auditory bones, and are thereby transmitted to the auditory nerves.

“The greater the degree of condensation of the sound-con-

## Statement of the case.

ducting medium is at a given time, the greater will be the amplitude of vibration of the membrane and auditory bones, and the greater the consequent result; and in the opposite case, so much the weaker. Hence, it is evidently the function of the auditory apparatus to impart with faithfulness to the auditory nerves every condensation and rarefaction which occurs in the surrounding medium. On the other hand, the function of transmitting to our consciousness both the number and amplitude of the resulting vibrations occurring within a given time devolves upon the auditory nerves.

"It is here, in our consciousness, that a certain complex phenomenon receives a specific name; it is here, in our consciousness, that the transmitted vibrations become tones [Tönen].

"Accordingly, that which is apprehended by the auditory nerves is the effect of a force, reaching to our consciousness, and which can be made more easy of comprehension, as to its duration and strength, by graphical delineation.

"For example, let the length of the line  $a$ — $b$  represent a definite period of time, the curves above this line the condensations (+),



and the curves below this line the rarefactions (—); then every ordinate erected at the end of any abscissa will indicate, at the moment of time indicated by this abscissa, the degree of condensation in consequence of which the membrane of the drum vibrates.

"The ear is not capable of perceiving more than can be represented in this way, or more than can be represented by similar curves; this is, however, sufficient to convey to our consciousness any single tone [Ton] or any required combinations of tones. For if several tones are generated simultaneously, then the tone imparting medium is influenced by several forces, acting at the same time, and subject to mechanical laws.

## Statement of the case.

“If all the forces act in the same direction, then the amount of motion is in proportion to the sum of all the forces; if, on the other hand, the forces act in opposing directions, then the amount of motion is in proportion to the difference between the opposing forces.

“From these principles it follows that the curves representing the condensations of a number of simultaneously generated tones may be combined in a single curve of condensation, which will indicate with precision what our ear apprehends through the reception of these simultaneously acting tones.

“The objection generally made to this proposition, that a musician, or any person, is able to distinguish the simple tones out of which these composite curves are formed or arise, should not be allowed to militate against it, as it is also possible for some who are familiar with the study of colors to distinguish, in green, for example, the mixture of yellow and blue, in their varied shades; and the one phenomenon, as well as the other, is referable to the fact that each observer is very familiar with the factors of that product which has been conveyed to his consciousness.

“By the explanations heretofore given, it is easy to construct the curves representing the condensations of various tones, chords, etc., and a few examples are given by way of illustration:

“Fig. 1, Plate VIII, represents a composite curve formed of three tones, in which all the proportions of the components recur successively.

“Fig. 2 represents a similar curve formed of more than three tones; in this case, however, it is no longer possible to represent the proportions so clearly in the drawing, yet an experienced musician will be able to discern them even here, although in practice it might be difficult for him to recognize the separate tones in such a chord.

“The advantage of representing the operation of tones upon the human ear after this manner is that it gives the



Leqat Reproduction von Tönen auf elektro galvanischem Wege.

Tafel VIII.

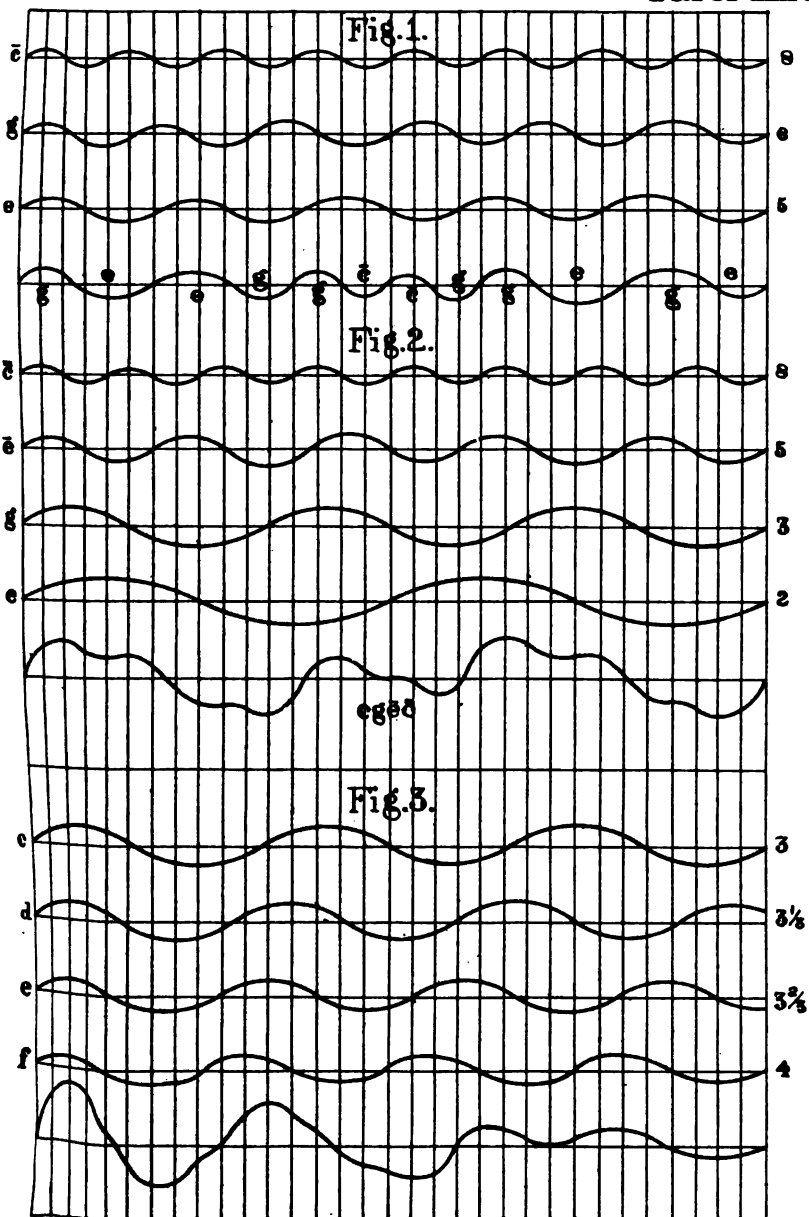

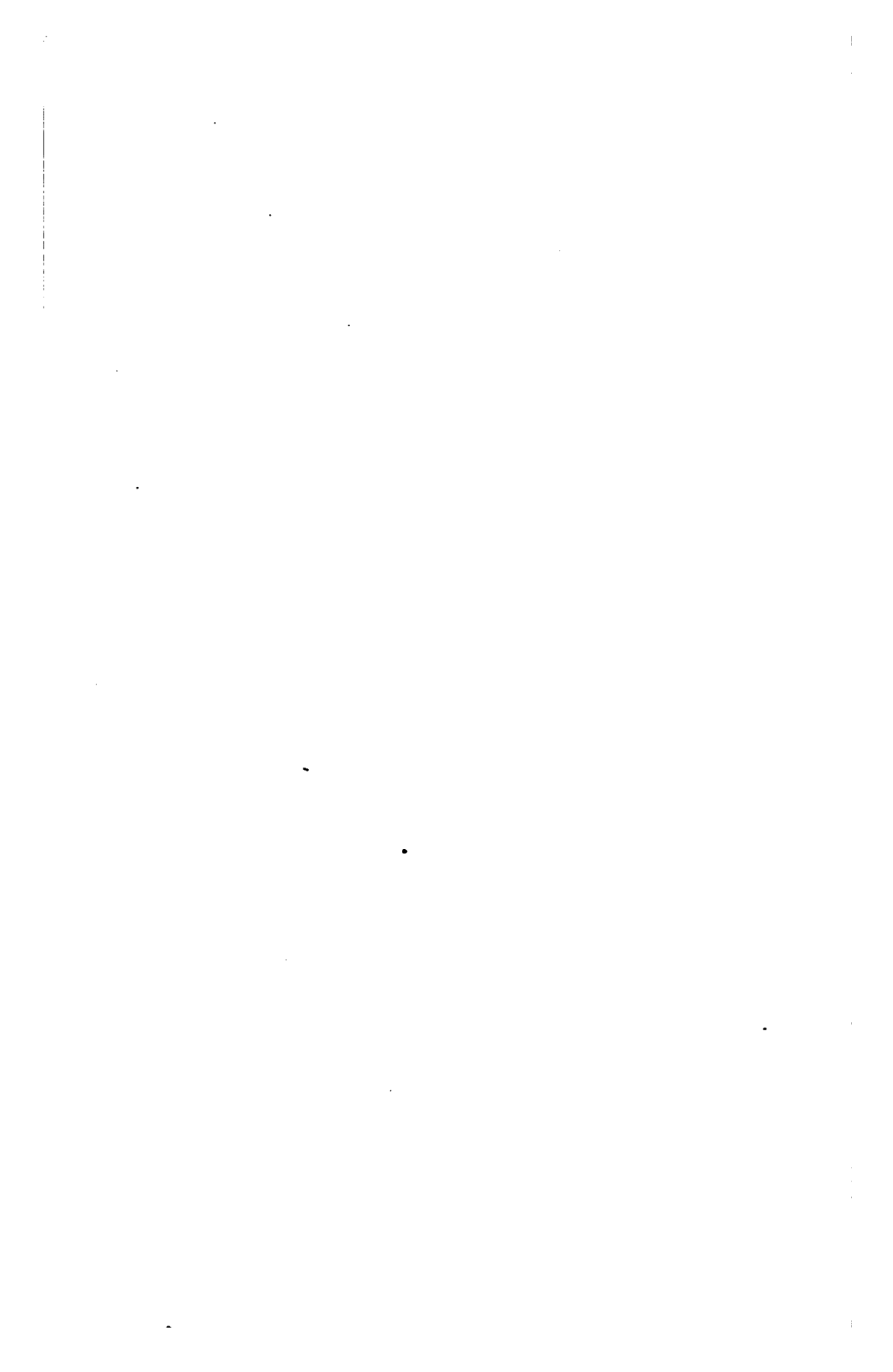

## Statement of the case.

clearest view possible of the course of the process ; the representation here given also shows why a discord [Dissonanz], Fig. 3, must affect the ear disagreeably.

“This apparent digression from the subject under consideration was necessary to demonstrate that as soon as we are able, in any place and in any manner, to reproduce vibrations of such curves and intensities as are equivalent to the curves and intensities of the vibrations of any particular tone, or of any particular combination of tones, we shall have the same impressions as were produced upon us by this original tone, or these original combinations of tones.

“The apparatus described hereafter offers the possibility of producing these vibrations in every manner desired ; and by the use of galvanic electricity it is possible to evoke, at any distance, vibrations like [gleiche] those which have been so produced, and in this way to reproduce at any place the tones which have been generated at another place.

“In plate IX, Fig. 4, A is the tone transmitter [Tonangeber], and B the tone receiver [Tonempfänger], and these two instruments are set up at different stations. I must observe at the outset that the arrangement of the instruments for sending backwards and forwards is omitted for greater clearness ; and likewise, as the whole thing is not presented as a completed fact, but only to call to the notice of a wider circle what has been already ascertained, the possibility of the working of the apparatus at a distance greater than the limited direct working allows at present is left out of consideration, since these points are easily accomplished by mechanical arrangements, and since the most important facts of the phenomena treated are not influenced thereby.

“Let us now turn to the tone transmitter, Fig. 4, A. This on the one hand is connected by the metallic conductor with the tone receiver, Fig. 4, B, at a neighboring station ; on the other hand it is connected by means of the electric battery C with the earth, or with the metallic return conductor. The tone transmitter, Fig. 4, A, consists of a conical

## Statement of the case.

tube *a b*, about 15 centimetres in length, having a front opening of about 10 centimetres, and a rear opening of about 4 centimetres.

“It appears by practical experiments that neither the material of this tube nor any increase in its length influenced the accuracy of the action of the apparatus. An enlargement of the diameter of the tube impairs the working of the apparatus, and it is desirable that the inner surface of the tube be as smooth as possible. The smaller or rear end of the tube is closed by a collodion membrane *o*, and upon the centre of the circular surface of this membrane rests one end *c* of the lever *c d*, the supporting point *e* of which is sustained by a bracket, and is kept in electrical connection with the metallic conductor. The proper lengths of the respective arms *c e* and *e d* of this lever are regulated by the laws of the lever. It is advisable to make the arm *c e* longer than the arm *e d*, in order that the least motion at *c* may operate with greatest effect at *d*. It is also desirable that the lever itself be made as light as possible, that it may follow the movements of the membrane. Any inaccuracy in the operation of the lever *c d* in this respect will produce false tones at the receiving station. When in a state of rest the contact at *d g* is closed, and a delicate spring *n* maintains the lever in this position.

“The second part of the apparatus, the standard *f*, consists of a metallic support, connected with one pole of the battery *C*, the other pole of which is connected to the earth, or to a metallic return wire leading to the other station.

“Upon the standard *f* is arranged a spring *g*, with a contact-point corresponding to the contact-point *d* of the lever *c d*; the position of *g* is regulated by the screw *h*.

“In order not to impair the operation of the apparatus by the action of the air-waves against the rear side of the membrane, it is desirable to place a disc of about fifty centimetres in diameter at right angles to the longitudinal axis of the

**v. Legat, Reproduction von Tönen auf elektro-galvanischem Wege.**

*Fig. 14.*

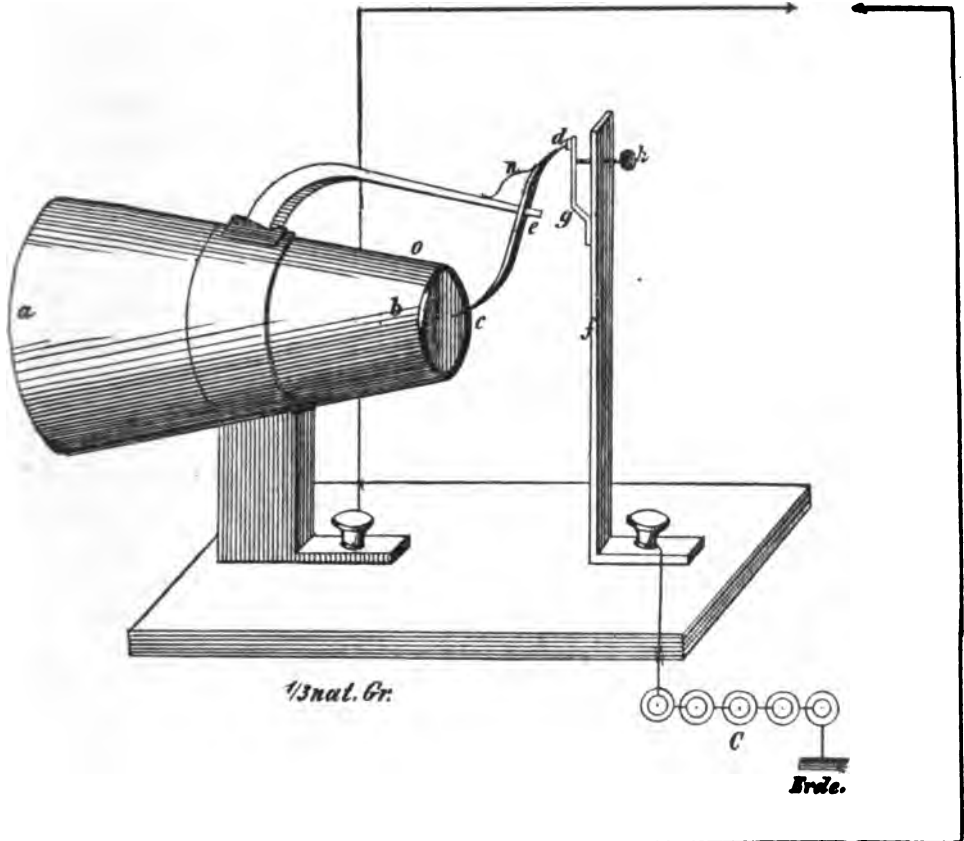

*1/3 nat. Gr.*

*Erde.*

*Fig. 15.*

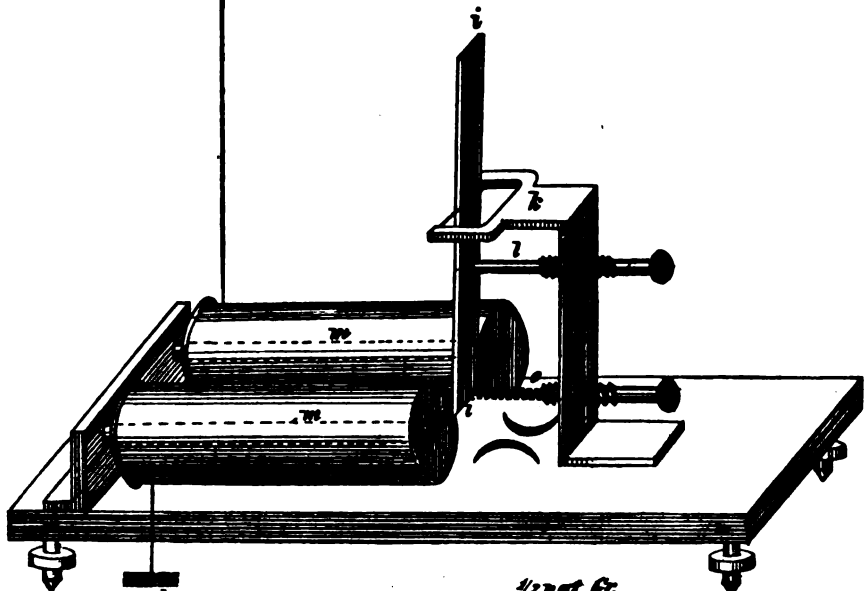

*1/2 nat. Gr.*

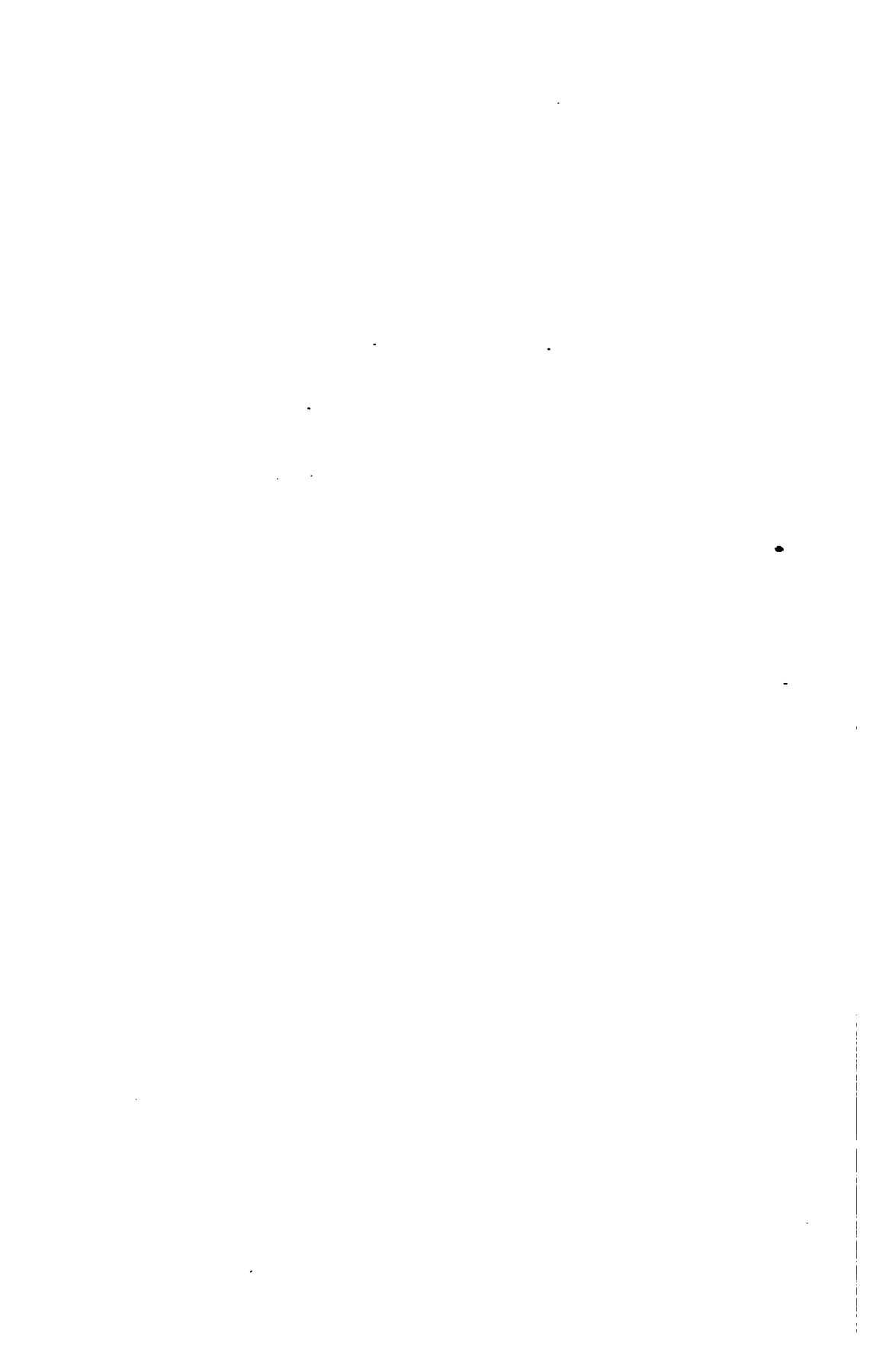

## Statement of the case.

tube *a b*; this disc may be attached to the tube by a fastening surrounding its outer circumference.

"The tone receiver, Fig. 4, B, consists of an electro-magnet *m m*, which rests upon a sounding-board *n w*; its coil is connected respectively with the metallic conductor and the earth or the metallic return conductor.

"Facing the electro-magnet *m m* is an armature, to which is attached a very long but light and broad lever *i*.

"The lever *i* with the armature is suspended from the standard *k* in the manner of a pendulum, its motion being regulated by means of the screw *l* and the spring *q*.

"In order to increase the capacity of the apparatus, the tone receiver may be placed at one of the focal points of an elliptical chamber of suitable size, and the listener may place his ear at the other focus of this chamber.

"The operation of the apparatus described is as follows:

"When at rest the galvanic circuit [Kette] is closed. When the air which is in the tube *a b* of the apparatus, Fig. 4, A, is alternately condensed and rarefied, by speaking into it (or by singing or introducing the tones of an instrument), a movement of the membrane closing the smaller opening of the tube is produced, corresponding to such condensation or rarefaction. The lever *c d* follows the movements of the membrane, and opens and closes [öffnet and schliesst] the galvanic circuit [Kette] at *d g*, so that at each condensation of the air in the tube the circuit is opened, and at each rarefaction the circuit is closed [ein Oeffnen und ein Schliessen erfolgt].

"In consequence of this operation, the electro-magnet of the apparatus, Fig. 4, B, in accordance with the condensations and rarefactions of the column of air in the tube *a b*, Fig. 4, A, is correspondingly demagnetized and magnetized [demagnetisirt und magnetisirt] and the armature of the magnet is set into vibrations like those of the membrane, in the transmitting apparatus. But the beam [Balken] *i* attached to the

## Statement of the case.

armature communicates these corresponding vibrations of the armature to the air surrounding apparatus Fig. 4, B, which finally transmits the vibrations so produced to the ear of the listener.

“We have not here to consider the question of the transmission [Fortpflanzung] of tones by means of the galvanic current, but only of the conveyance [Uebertragung] of generated sounds to another place, and in this way that at the latter place a similar cause is produced, and a similar effect obtained. It must not be ignored, however, that while the apparatus described reproduces the exact number of the original vibrations, but not of the same strength [die gleiche Stärke der reproducirten Schwingungen noch nicht erreicht wurde]; and that the achievement of this result is reserved for an improvement of the apparatus.

“In consequence of the imperfection of the apparatus at this time, the minor differences of the original vibrations are distinguishable with more difficulty—that is, the vowel sounds appear more or less indistinct—inasmuch as each tone depends not merely upon the number of the vibrations of the medium, but also upon its condensation and rarefaction.

“This also explains why chords and melodies were transmitted with marvelous accuracy in the practical experiments hitherto made, while single words in reading, speaking, etc., were less distinctly recognizable, although even in these the inflections of the voice, as in interrogation, exclamation, surprise, calling, etc., were clearly reproduced.

“There is no doubt that the subject we have been considering before it becomes practically valuable for use, will require considerable improvement; it will especially be necessary to perfect the mechanism of the apparatus to be employed; but I am convinced by repeated practical experiments, that it is of the greatest theoretic interest to pursue these investigations, and also that a development of practical value will not elude our intelligent century.”



## Statement of the case.

## INDUSTRIAL GAZETTE.

"*Deutsche Industrie Zeitung, 1863, Chemnitz. April 17, 1863, No. 16, page 184.*

"*Industrial Queries for Exciting Interest and Eliciting Responses.*"

"Of late there has been talk in newspapers about producing definite tones at a distance, similarly to telegraphic dispatches, such, for instance, as conducting the acoustic effects of an instrument far beyond the reach of the audibility of its sound. Do these communications rest upon actual facts?"

(From same Gazette. May 1, 1863, No. 18, page 208):

"Answers. Answer to question in No. 16, page 184. Transmission of Tones by Electricity. According to 'Böttger's Notizblatt,' 1863, No. 6, successful experiments in 'telephony' were made in October, 1861, at Frankfort-a-M. by Professor Ph. Reis, so that it seems not impossible to carry on conversations at miles distance, and even to convey the voice itself with its peculiar undulations, and also the tones of a musical instrument. Heretofore the voice could be reproduced from one house to another only for a distance of 300 feet by means of a peculiar and ingenious apparatus. The arrangement of the same was essentially as follows: The waves of sound were taken up by an elastic surface, and transmitted to a light commutator introduced into the circuit of a galvanic battery (einer federnden Commutator eingeschaltet in den Leitungsdraht). At the other end of the line was introduced a coil of copper wire, inside of which was an iron wire resting upon a sounding board, that was thrown into sonorous vibrations by the changes of current depending upon the waves of sound."

(May 29, 1863, No. 22, page 249.)

"The reproduction of tones by electro-galvanic means (with a drawing which is the same as the drawing of the apparatus in the Legat article, No. 8, pp. 539-545, *supra*).

"Although this subject has already been discussed by us (No. 18, page 208), on account of the great interest it offers

## Statement of the case.

we shall return to it more in detail. We enclose a drawing of an apparatus used by Mr.-Ph. Reis, in Frankfort-a-M, taken from the Zeitschrift des Deutsch-Oesterreichschen Telegraphen-Vereins, 1862, folios 6, 7, and 8. We take the liberty of following the lead of the above-mentioned source in entering into a short discussion of the nature of tones.

“The undulations of the air that excite in us, by operating upon the ear, the sensation of sound, by setting the drum of the ear into vibration, are transmitted, as is well known, by a series of levers of admirable delicacy; that is, by the small bones of the ear (hammer, anvil, and stirrup) to the inner portion of the ear, and to the nerves that lie at that point. The attempt to reproduce tones depends upon the following: To set in motion an artificial imitation of this series of levers by the vibration of a membrane which takes the place of the drum, and to make use of them to open and close a galvanic circuit which is connected by a metallic conductor with a remote station.

“If we take into consideration the phenomena that take place when we perceive a sound by the sense of hearing, we find that every tone is the result of rarefactions and condensations of the air repeated several times in a certain period. At every condensation the membrane of the drum is pressed inwards, and at every rarefaction outwards. These vibrations produce a simultaneous motion of the small bones of the ear and a consequent transmission to the nerves of the ear. The greater the compression of the sound-conducting medium at any particular moment, the greater is also the amplitude of vibration of the membrane and small bones of the ear, and *vice versa*. The object, therefore, of the organs of hearing is to transmit with certainty the rarefactions and condensations of the sound-conducting medium to the nerves of hearing. On the other hand, it remains their object to bring to our perception the vibrations occurring in a given time with reference to number as well as to amplitude.

## Statement of the case.

It is only in our perceptions that a given combination receives a definite name; that vibrations become sounds.

“Anything other than the effect of such single vibrations the organs of hearing are unable to take up, and these organs themselves are competent to perceive single tones as well as combinations of tones, for if several tones are produced at the same time, the sound-conducting medium is under the influence of several simultaneous forces which, according to the laws of mechanics, can be replaced by a force which produces the same effect as all the single ones together. If all the forces operate in the same direction the magnitude of the motion is proportional to the sum; if they operate in opposite directions the magnitude of the motion is proportional to the difference of the opposite forces. In that way several simultaneous tones operate upon our hearing simply by a definite alternation of rarefactions and condensations of the sound-conducting medium as in the case of single tones. The tone itself depends apparently only upon the number of vibrations and the power upon the amplitude of the vibrations (perhaps also the strength).

“Now, as regards the apparatus, the upper figure is the transmitter and the lower one the receiver or reproducer.

\* “The transmitter consists of a metallic conical pipe  $a b$ , about 15 centimetres in length, 10 in diameter at  $a$  and 4 in diameter at  $b$ . At  $b$  the opening is closed by a membrane  $o$  of collodion stretched tight. Upon the centre of the same rests the end  $c$  of lever  $c d$ , whose fulcrum is placed at  $e$  on a support. The lever is to be made as light as possible, and its arm  $c$  longer than its arm  $d$ , so that the smallest motion at  $c$  will operate at  $d$  with the greatest amount of force. In the condition of rest the contact  $d g$  is closed and a weak spring  $n$  holds the lever fast in this position of rest.” Besides, there is attached to the apparatus a metallic standard  $f$ , connected with one pole of the battery, while the other pole is led to the ground through  $e$ . On the standard  $f$  is

\* The letters refer to the preceding cut (page 155.)

## Statement of the case.

secured the spring *j* opposite the contact-point *d* of lever *c* at *d*, the position of which (spring) can be regulated by a screw *h*.

“The receiver consists of an electro-magnet *m m* resting upon a sounding-board *R*, and whose coils are in connection with a metallic conductor and with the earth at *E*. Opposite the electro-magnet is an armature connected with a lever, as long as possible, but light and broad. This lever is fastened to the support *k* after the manner of a pendulum, and its motions are regulated by a screw *b* and spring *g*.

“To increase the efficiency of the apparatus, the receiver and reproducer can be set up in one focus of an elliptical concavity of proper size, while the listening ear of the hearer is placed in the other focus.

“The operation of the apparatus is now as follows: The tones of the voice or of an instrument are conducted into the conical pipe *a b*. By reason of their vibration, the membrane is set into similar vibration, and in this way operates the opening and closing of the electric conductor. In consequence of this, the magnet in the receiver will be magnetized and demagnetized corresponding to the vibration of the tones, and the armature of the lever *i* is set in vibrations corresponding to those of membrane *a*. The wide surface of lever *i* transmits these vibrations to the air, and by this means they reach the ear of the hearer. In this transmission of tones, the only question is one of transmission of vibrations, a problem that magneto-electric telegraphy is certainly sufficiently far advanced to deal with.

“A friendly communication was sent us, some time ago, by Mr. J. F. Quilling, of Frankfort-a-M., according to which the capacity of the apparatus to transmit tones to a considerable distance clearly and with their characteristic timbre [Klangfarbe] is fully established. Mr. Q. writes us that by means of the telegraphic conductor with which the apparatus of Mr. Ph. Reis was connected, two remote parts of the city were united, and although it was not possible, with the

## Statement of the case.

present construction of the apparatus, to transmit spoken words [gesprochenen Wörter], they succeeded so well with the tones that were sung that not only were the melodies of songs reproduced distinctly and perfectly at a tolerably remote station, but known voices could be recognized. All present capable of judging, Mr. Q. adds, who availed themselves of the opportunity of witnessing the experiment, agreed that the possibility is before us of making one's self understood verbally, at any distance, in the way shown by Mr. Reis."

## BÖTTGER'S ARTICLE.

*Böttger's Polytechnisches Notizblatt, 1863, No. 61, p. 81.*

*On the Transmission of Tones at any Desired Distance by Means of Electricity. (Telephony.)*

"Two decades ago the problem of giving signs, by means of electricity, from distances had not yet been entirely solved. Since then telegraphy has reached such a perfection, and telegraph wires have so greatly spread, that even the keenest desires have not much left to ask for.

"Now there appears a first earnest trial to reproduce tones at any desired distance, by means of electricity.

"This first trial, which has been crowned with success, has been repeated in the lecture-room of the Physical Society, of Frankfort-on-the-Main, before numerous assembled members, on the 26th of October, 1861, by Mr. Ph. Reis, teacher of natural sciences, at Friedrichsdorf, near Frankfort. Into one part of his apparatus, located in a building about three hundred feet distant, and having all the doors and windows closed, melodies were sung, but not very loudly. The same could be heard by the members in the lecture-room, through the second part of the apparatus.

"These wonderful results were attained with the following very simple apparatus: A small, light box, a kind of hollow wooden tube, has a larger opening in the front, and a smaller one on the opposite side. The latter is covered with a very

## Statement of the case.

fine membrane (sausage skin), and the same is tightly stretched; a small, flexible piece or strip of platina, fastened to the wood of the box, touches the membrane at its centre, and a second strip of platina is fastened by one end to the wood at a different place, and has at its other end a fine horizontal point touching the other strip of platina, where it lies on the membrane.

“As is known, tones are produced by the rapid succession of condensations and rarefactions of the air. If the vibrations of the air, called waves, strike the thin membrane, they push the same against the strip of platina that touches it, and then allow it to immediately vibrate back into the hollow cube (called the artificial ear), and so cause the membrane to assume forms alternately bent towards the cube and from the same. The strip of platina lying against the membrane is thus set into a swinging motion, so that it is alternately pressed on to the platinum point of the second strip, and then leaves the same.

“If one of the strips is connected by a wire to one of the poles of a voltaic battery, and the electricity is conducted to any desired distance by a wire connected to the other pole, and is then carried through a helix six inches in length, wound with six layers of thin silk-covered copper wire, and from there is carried back to the second strip of platina on the wooden cube by means of an insulated wire, then, at every vibration of the membrane, an interruption of the current of electricity [Unterbrechung in der Strömung der Electricität] will be caused, as the point on the one strip of platina no longer touches the other strip. Through the hollow of the spiral a thin iron wire (a thick knitting-needle), about ten inches in length, is passed, so that it projects out of each end of the spiral about two inches, and these projecting ends each rest on a bridge of a sounding-board.

“It is known that if an electric current is passed through a helix that surrounds an iron wire, at every interruption a tone, produced by the vibrations of the iron wire, is audible.

## Statement of the case.

If the makings and breakings of the current [Unterbrechungen des Stromes] follow each other rather slowly, the different positions (in regard to the length of the bar) which the molecules will be caused to assume by the electricity will produce a tone, its so-called proper longitudinal tone, which depends on the length and thickness of the bar or wire.

“If the interruptions and reconnections of the current [Unterbrechungen des elektrischen Stromes] in the spiral take place faster than the vibrations of the smallest parts of the wire, which, in turn, depend upon the elasticity of the wire, they cannot complete their course, receive new shocks, the vibrations get to be smaller but more rapid, and as numerous as the interruptions follow each other. The piece of wire no longer gives its longitudinal tone, but a tone, which, according to the number of interruptions in a certain time, is higher if they are more frequent, and lower if they are less frequent. It is known that the pitch of a tone depends on the number of air-waves that follow each other in one second. We have seen that the number of interruptions of the electric current [Unterbrechungen des elektrischen Stromes] by the membrane and the strips of platina is dependent upon this.

“Consequently the iron wire must give a tone of the same pitch as the sound which was received by the membrane. As electricity is hardly impaired when conducted a great distance, if the proper apparatus is used, it is evident that a tone acting on a membrane in one place can be made audible at any desired distance by the iron wire.

“That the tone is made audible only by electric vibrations, and not by direct transmission of the air-waves through the wires, can be most strikingly proved by noticing the fact that no tone is heard at the spiral if a good, short circuit be established; *i. e.*, for instance, a small strip of metal is laid across the two wires, directly in front of the spiral. The reproduced tones are weaker than the originals, but the number of vibrations is the same. It is easy to reproduce

## Statement of the case.

the tones in the proper pitch. As the vibrations are smaller, which is the cause of the weakness of the tone, it is much more difficult, however, for our ear to estimate the difference in the size of the vibrations.

“The character of a tone depends upon the number of swellings it has; *i. e.*, with tones of the same depth, consequently of the same number of waves per second, such as having the fourth, sixth, eighth, tenth, or sixteenth wave stronger than the rest.

“The physicists have shown that if a spring is vibrated by the teeth of a cog-wheel, the first vibration is the greatest, and every following one is smaller. If, however, before the spring comes to rest, another tooth strikes it, then the next vibration will be equal to the first strongest one, but the vibrations of the spring will not be any more numerous than before. Vowel tones can be artificially produced in this way.

“Although we may be far from being able to converse with a friend a hundred miles away and recognize his voice, as though he was sitting along side of us, the impossibility of attaining this result can no more be claimed.

“The probability that this result will be attained is almost as great as, by the wonderful experiments of Niepce, the reproduction of natural colors by photography.”

## REIS' LETTER TO LADD.

*Journal of the Society of Telegraph Engineers, and of Electricians for March, 1883, No. 46.*

## REIS' TELEPHONE.

“The following is a copy of an autograph description of Reis' telephone which has been presented to the library by Mr. William Ladd, member:

## “INSTITUT GARNIER, FRIEDRICHSDORF.

“DEAR SIR:—I am very sorry not to have been in Frankfurt when you were there at Mr. Albert's, by whom I have been informed that you have purchased one of my newly-



## Statement of the case.

invented instruments (telephone), though I will do all in my power to give you the most ample explanations on the subject. I am sure that personal communications would have been preferable, specially as I was told that you will show the apparatus at your next scientific meeting, and thus introduce the apparatus in your country.

“Tunes and sounds of any kind are only brought to our conception by the condensations and rarefactions of air or any other medium in which we may find ourselves. By every condensation the tympanum of our ear is pressed inwards, by every rarefaction it is pressed outward, and thus the tympanum performs oscillations like a pendulum. The smaller or greater number of the oscillations made in a second gives us, by help of the small bones in our ear and the auditory nerve, the idea of a higher or lower tune.

“It was no hard labor, either to imagine that any other membrane besides that of our ear could be brought to make similar oscillations, if spanned in a proper manner, and if taken in good proportions, or to make use of these oscillations for the interruption of a galvanic current. However, these were the principles which guided me in my invention; they were sufficient to induce me to try the reproduction of tunes at any distance. It would be long to relate all the fruitless attempts I made until I found out the proportions of the instrument and the necessary tension of the membrane. The apparatus you have bought is now what may be found most simple, and works without failing when arranged carefully in the following manner:

“The apparatus consists of two separated parts, one for the singing station, A, and the other for the hearing station, B.

“The apparatus A is a square box of wood, the cover of which shows the membrane, *c*, on the outside, under glass. In the middle of the latter is fixed a small platina plate to which a flattened copper wire is soldered, on purpose to conduct the galvanic current. Within the circle you will

## Statement of the case.

further remark two screws: one of them is terminated by a little pit in which you put a little drop of quicksilver, the other is pointed. The angle, which you will find lying on the membrane, is to be placed according to the letters, with the little hole *a* on the point *a*, the little platina foot *b* into the quicksilver screw, the other platina foot will then come on the platina plate in the middle of the membrane.

“The galvanic current coming from the battery (which I compose generally of three or four good elements) is introduced at the conducting screw near *b*, wherefrom it proceeds to the quicksilver, the movable angle, the platina plate and the complementary telegraph to the conducting screw *s*. From here it goes through the conductor to the other station B, and from there returns to the battery.

“The apparatus B, a sonorous box, on the cover of which is fixed the wire spiral with the steel axis, which will be magnetic when the current goes through the spiral. A second little box is fixed on the first one, and laid down on the steel axis to increase the intensity of the reproduced sounds. On the small side of the lower box you will find the corresponding part of the complementary telegraph.

“If a person sings at the station A, in the tube *x*, the vibrations of air will pass into the box and move the membrane above, thereby the platina foot *c* of the movable angle will be lifted up, and thus will open the stream at every condensation of air in the box. The stream will be re-established at every rarefaction. In this manner the steel axis at station B will be magnetic once for every full vibration, and, as magnetism never enters nor leaves a metal without disturbing the equilibrium of the atoms, the steel axis at station B must repeat the vibrations at station A, and then reproduce the sounds which cause them. *Any* sound will be reproduced if strong enough to set the membrane in motion.

“The little telegraph which you find on the side of the apparatus is very useful and agreeable for to give signals between both of the correspondents. At every opening of the

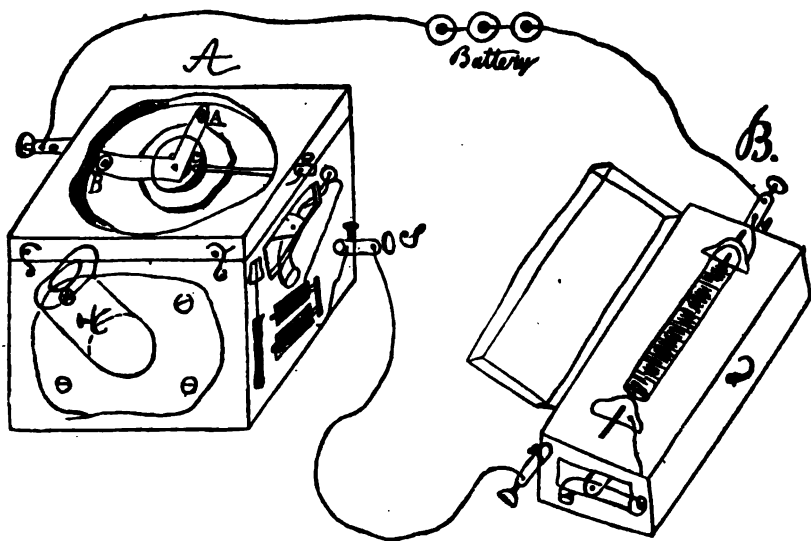

Reis's Telephonic Apparatus.—Facsimile of Drawing sent by Reis to Mr. Ladd.

---



## Statement of the case.

stream, and next following shutting, the station A will hear a little clap, produced by the attraction of the steel spring. Another little clap will be heard at station B in the wire spiral. By multiplying the claps and producing them in different measures, you will be able as well as I am to get understood by your correspondent.

"I am to end, sir, and I hope that what I said will be sufficient to have a first try; afterwards you will get on quite alone.

I am, sir,

"Your most obedient servant,

"PH. REIS.

"FRIEDRICHSDORF, 13-7-63.

"To Mr. William Ladd."

## BRITISH ASSOCIATION REPORT ON REIS.

*Report of the Thirty-third Meeting of the British Association for the Advancement of Science, in August and September, 1863, published 1864.*

*On an Acoustic Telegraph, by W. Ladd.*

"This instrument consists essentially of two distinct pieces of apparatus; that for transmitting the signal has a small mouthpiece. On the right-hand side there is a finger key forming part of the circuit, and an electro-magnet, with a vibrating armature and binding screw to connect with one of the line-wires. Within a case under a glass cover is an elastic membrane, in the centre of which is fixed a platinum plate in connection with the finger key. A like piece of angular metal resting on three pins is so placed that the pin at the angle rests on the plate in the centre of the membrane, the other two resting in cups on its edge so as to allow a free motion on the points. In the body of the receiver box is suspended a soft-iron core surrounded by a coil of silk-covered wire, one end of which is in connection with a finger key and the other with the binding screw. The method of producing sound in the receiving instrument depends upon the fact that at the moment of magnetizing or demagnetizing

## Statement of the case.

a piece of iron, there is an alteration in the arrangement of the particles which gives rise to a slight ticking noise. Having connected the transmitter by means of an insulated wire with the receiver, and the binding screws having been brought in connection with a battery of three or four elements, if the finger key on the transmitter be pressed the person at the receiving station hears the ticking noise. To convey a musical note or sound the operator places his mouth to the tube in front of the instrument and sings a note, when immediately the membrane begins vibrating in accordance with the note sounded, and at each vibration breaks contact between the pin and plate in its centre. This forming part of the circuit causes the iron core in the receiving instrument to be magnetized and demagnetized a number of times equal to the number of vibrations of the membrane, and so conveys to the receiver an impression of a musical sound. The finger keys and small magnet at the sides of the instruments are for the purpose of varying the methods of communication by the combination of single sounds, and can also be used with the other parts for the purpose of regulating the lengths of the notes and dividing them into varying portions, so as to form a sound alphabet, somewhat similar to the signals written by Morse's telegraph."

PROSPECTUS OF MR. ALBERT.

J. Wilh. Albert,  
Mechanician,

Frankfort-on-the-Main.

FRANKFORT-A-M., August, 1863.

"SIR:—I take the liberty of sending you the accompanying prospectus, begging you to give it your kind attention; it relates to the very interesting apparatus of Mr. Reis, for the production of tones with the aid of galvanism:

THE TELEPHONE.

"This apparatus, which can be had through me, is at all times exhibited for inspection in my warehouse, and besides

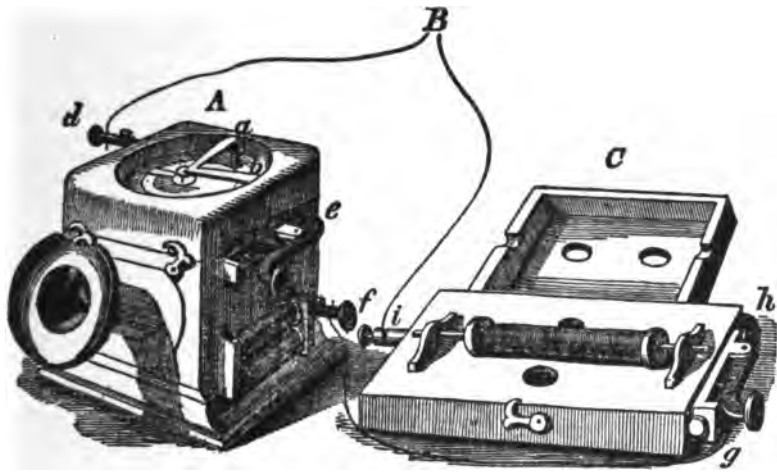

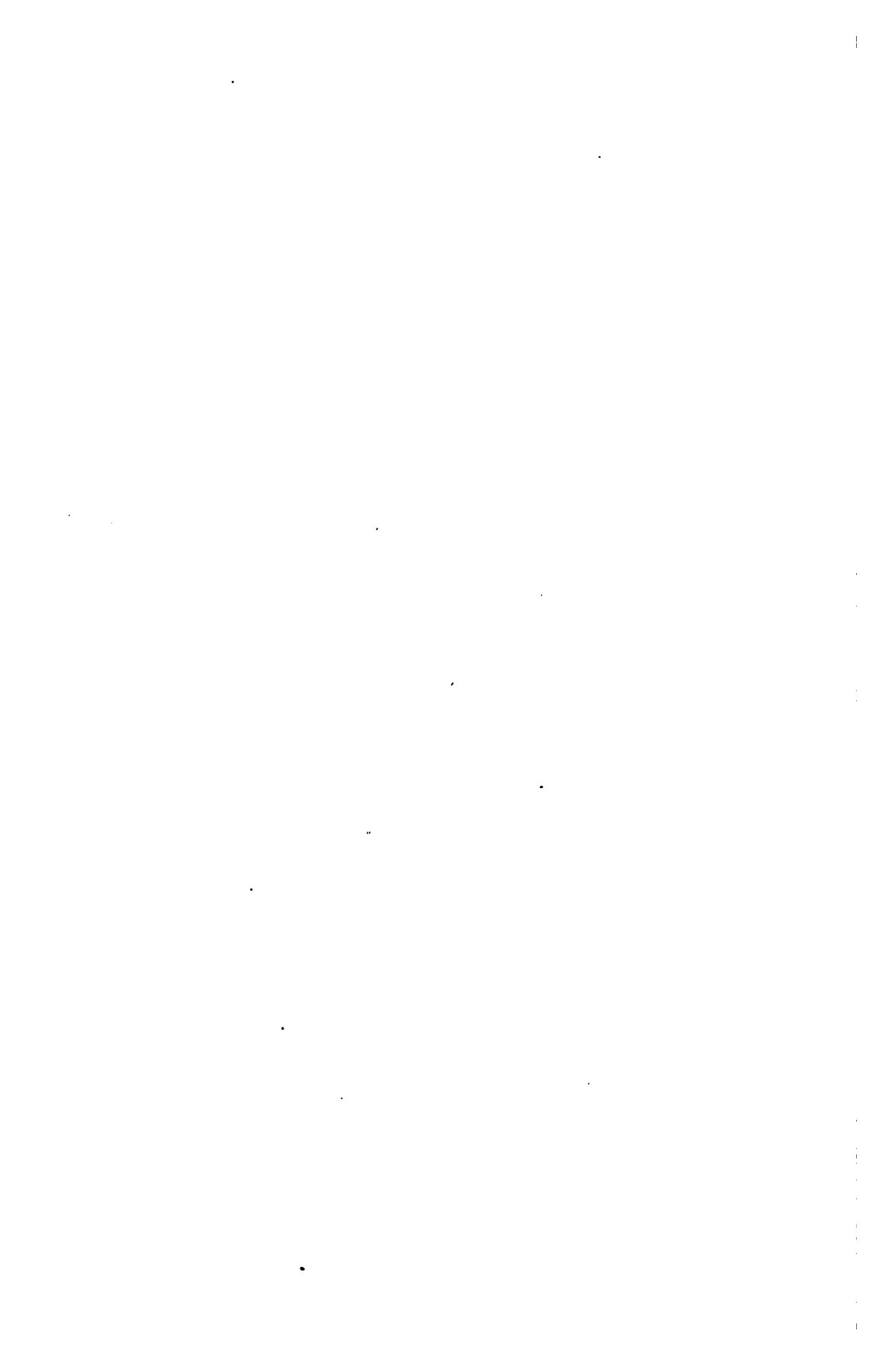



## Statement of the case.

I am quite willing to give every information regarding it. My warehouse of physical, optical, and chemical instruments and apparatus is now: Neue Mainzerstrasse-No. 34 AM. Taunusthor, only three minutes' walk from the several railroad stations, and therefore may be visited by any one, however short his stay in Frankfort may be."

"Awaiting your kind order, I am,

" Respectfully yours,

" J. WILH. ALBERT."

## CIRCULAR OF REIS OF AUGUST, 1868.

(This is on the same sheet of paper as the foregoing.)

"SIR :—Having succeeded two years ago in demonstrating the possibility of reproducing tones with the aid of the galvanic current, and in manufacturing an apparatus for that purpose, the subject has been so highly appreciated by the most renowned men of science, and I have received so many encouragements, that I have striven since that time to improve my originally very imperfect apparatus, in order to give to others also the facility of experimenting.

"I am now able to offer an apparatus which satisfies my expectations, and with which every physicist will succeed in repeating these interesting experiments regarding the reproduction of tone (Tonreproduction) at distant stations.

"I believe that it is the wish of many that these instruments should come into the possession of laboratories; as, however, their manufacture demands a complete knowledge of the leading principles, and a great experience in this matter, I have resolved to make the most important part myself, and to intrust to the mechanician only the secondary parts and the external outfit. Mr. J. Wilh. Albert, mechanician at Frankfort-on-the-Main, is commissioned to sell them. I have enabled him to offer them at the prices of 21 and 14 florins (12 and 8 Prussian thalers) in two qualities, which differ only in the external outfit. The instruments can also be had directly from me at the same price, by cash payment.

## Statement of the case.

Every apparatus is examined by me before being shipped, and has attached my name, the serial number, and the date of construction.

“ Friedrichsdorf b. Homburg, v. d. Höhe,

“ August, 1863.

“ PHIL. REIS,

*Teacher at L. F. Garnier's Boys' Institute.*”

In manuscript, on the foregoing, is the following :

“ Descriptions of the above are to be found in Müller-Pouillet's *Lehrbuch der Physik* Braunschweig, Vieweg & Son; Pisko, *die Neueren Apparate der Akustik*, Wien, Gerold's Son; 1865.”

## REIS' DESCRIPTIVE CIRCULAR.

(This and the foregoing are on two similar printed sheets.)

“ The apparatus consists of two parts, as may be seen in the woodcuts above, the telephone proper A, and the reproducing apparatus C. These two parts are to be placed at such a distance from each other that singing or the sound of a musical instrument can be heard in no other manner except through the apparatus from one station to another.

“ Both parts are connected with each other, and with the battery B, the same as in an ordinary telegraph. The battery must be sufficient to produce at station A the attraction of the armature of the electro-magnet placed at one side (three or four six-inch Bunsen cells are sufficient for several hundred feet of distance).

“ The galvanic current then goes from B to the binding post *d*, from there through the copper strip, to the platina disc in the centre of the membrane, then through the foot *c*, of the angle towards the binding post B, *in the small hollow of which a drop of quicksilver is inserted*. From here the current goes through the small telegraph apparatus *e f*; then to the key of the station C, and through the coil surrounding *i* back to B.

## Statement of the case.

“If, now sufficiently strong tones are produced before the mouthpiece, their vibrations will put in motion the membrane and the angular little hammer [winkelförmige Hämmerchen] which lies on it; for every full vibration the circuit is once opened and again closed [einmal geöffnet und wieder geschlossen], and thereby are produced at station C in the core of the coil, just the same number of vibrations [ebenso-viele schwingungen hervorgebracht] which are there perceived as tones or as combinations of tones [Accords]. By placing the cover tightly over the axis of the coil the tones at C are greatly strengthened. Besides the human voice [Menschenstimme] there can be reproduced (according to my experience) just as well the tones [Töne] of good organ pipes from F to C and those of the piano; to that end the box *a* must be placed on the sounding board of the piano; out of thirteen chords a skilled experimenter could make out ten clearly. The telegraph apparatus placed on one side is evidently unnecessary for the reproduction of tones, but it is a very useful addition for convenient experimenting. With its aid it is possible to easily and surely make one's self intelligible [sich verständigen] with the person at the other station.

“This may be done somewhat in the following simple manner: After the apparatus has been put up completely, one satisfies one's self of the continuity of the connection and the strength of the battery by opening and closing the circuit whereby at A is heard a striking of the armature, and at C a very perceptible ticking of the coil.

“By a quick succession of makes and breaks at A, C is asked whether he is ready for experimenting, whereupon C answers in the same manner.

“By agreement between the two stations simple signals can be given by opening and closing the circuit 1, 2, 3, or 4 times, *e. g.*, one stroke—sing; two strokes—speak, etc.

“I telegraph words by numbering the letters of the alphabet and communicating their numbers.

## Statement of the case.

“ 1 stroke A,  
 2 strokes B,  
 3 strokes C,  
 4 strokes D,  
 5 strokes E, etc.

“ Z would consequently be indicated by 25 strokes.

“ But these numbers of strokes would take too much time and not be sure in counting. Therefore I put a dactyl for every 5 strokes, hence

“ —U U for E,

“ U U and 1 stroke for F, etc. .

“ Z:—UU—UU—UU—UU—UU, which is quicker, and more easily executed and better understood.

“ Still better is it to indicate the letters by numbers which are in inverse proportion to the frequency of their occurrence.

“ 9 August, 1863, Friedrichsdorf, b Homburg, v. d. Höhe.

“ PHIL. REIS,

“ *Teacher of A. L. Garnier's Boys' Institute.*”

BÖTTGER'S ACCOUNT OF REIS' IMPROVED  
 APPARATUS.

*Dingler's Polytechnic Journal, Vol. 169, p. 399. Concerning the Improved Telephone.*

“ In the meeting of the Physical Society, held on July 4, at Frankfort-a-M, a member of the society, Mr. Philip Reis, from Friedrichsdorf, near Homburg before the Heights, exhibited some of his improved telephones (Apparatus for the Reproduction of Tones at any desired distance by means of the Galvanic Current). It is two years since Mr. Reis first gave publicity to his apparatus, and although the performances of the same in their simple primitive form were astonishing, yet they had this great defect, that experimenting with the same was possible only for the inventor. The instruments exhibited in the above-mentioned meeting scarcely reminded one of the earlier forms.

## Statement of the case.

"Mr. Reis has striven to give the same a form pleasing to the eye, so that they now will worthily fill a place in every physical cabinet. This new apparatus can now be easily managed (worked) by every one, and works with great certainty. Melodies sung quite lightly at a distance of about three hundred feet were reproduced by the instrument set up much more distinctly than formerly. The musical scale was especially sharply reproduced.

"The experimenters could even reproduce words, although, indeed, only such as had been often heard by them.

"In order now that others, less experienced, may be able to even make themselves understood through the apparatus, the inventor has fixed at the side of the same a small, yet, according to his explanation, entirely sufficient arrangement, whose speed of communication indeed is not so great as that of the more recent telegraphs, but which works very surely, and assumes no especial skill in the person working it. We would call the attention of gentlemen busying themselves with physics to the fact that the inventor now has this interesting apparatus manufactured for sale under his supervision (the principal [important] parts he makes himself), and the same can be had of him directly or through the instrument maker, Wilhelm Albert, at Frankfort-on-the-Main, in two qualities, differing only in outward finish, at 14 and 21 florins, respectively (Böttger's Polytechn. Notizblatt, 1863, No. 15)."

## REIS' IMPROVED APPARATUS.

*Die Fortschrittder Physik, Berlin, 1863, p. 96.*

*Ph. Reis' Improved Telephone (Dingler, CLXIX, 399).*

"Herr Reis is said to have improved, quite essentially, his telephone. With the former instrument, experimentation was possible at the hands of the inventor himself, only.

"The instrument (to be had at Albert's, in Frankfurt-a-M, for 14-21 fl.) has now, it is reported, a shape more pleasing to the eye, and can be operated easily by any one. At a distance of 300 feet tunes were reproduced far more distinctly

## Statement of the case.

than ever before. The scales are reproduced with peculiar precision. The experimenters were able even to communicate words, only such, however, as had been already often heard by them."

## GARTENLAUBE REIS' IMPROVED APPARATUS.

(*The "Gartenlaube,"* No. 51, December, 1863.)

*The Musical Telegraph.*

"The surprising results in telegraphing have often excited the question whether it may not be possible to communicate the language of sound itself to a distance. The trials made in this direction had till now produced no satisfactory results, because the vibrations of sound-conducting bodies soon diminish so much in force that they are no more perceptible for our senses.

"People, perhaps, had already thought of a reproduction of sound at certain distances with the aid of the electric current, but those who have been the best fitted to attack the question by their knowledge and resources, were the ones who doubted the most of a practical solution of that question. Those who are but superficially acquainted with natural science do not see the many difficulties this problem offers, if they are at all acquainted with it. Thus, about eleven years ago, a young man, Mr. Philip Reis, at present teacher of natural science at the Garnier Institute for Boys at Friedrichsdorf, near Homburg, had the hardihood to work at the solution of this problem. But soon he was obliged to desist from it because his very first effort seemed to convince him of the impossibility of a solution. Later, however, after further studies and many experiments, he saw that his first effort was but a rudimentary one, and by no means convincing. However, he did not recommence to attack the question seriously for some time, not feeling himself strong enough to vanquish the obstacles on his road, although he never banished his early idea entirely from his thoughts.

## Statement of the case.

“How can a single instrument reproduce simultaneously the combined effects of all the organs active in human speech?” This seemed to him the chief question. Later he put this question more methodically: “How does our ear perceive the composite vibrations of all the organs of speech acting at the same time?” or, expressed more generally, “How do we perceive the vibrations of several bodies sounding simultaneously?”

“If we throw a stone into quiet water there are produced on the surface uniform waves, which progress symmetrically outward; the further they go the weaker they become, till they finally disappear.

“It is quite similar with that what we call sound and tone. A body made to vibrate through any impulse affects the surrounding air, and causes waves in it, which follow each other at the same rate as the vibrations of the body. As those rings on the water consist in swellings and depressions, so also the vibrations of the air consist of alternate condensations and rarefactions. If they reach our ear, every condensation presses the tympanum towards the interior of the cavity, and puts in motion the adjacent group of small bones which communicate the motion to the liquid of the cochlea, in which the auditory nerves terminate. The latter are excited and produce the *sensation of sound*.

“Now, if the waves of vibration follow regularly and with a certain swiftness (sixteen in the second at least), we shall have the sensation of a musical *tone*. The latter is the *higher*; the quicker the condensations follow each other and the louder, the *stronger* or higher the waves rise, as it were.

“Our ear cannot perceive anything except condensations and rarefactions, wave crests and wave hollows. And, nevertheless, we receive the most varied auditory impressions, we distinguish the sound of the voices, we hear at the same time in quite different directions and can distinguish the different sources; nay, in a complete large orchestra, each of the numerous instruments is specially noticed by its peculiar

## Statement of the case.

sound, so that we decompose at every moment the total impression into its several parts, according to the height and depth, strength and weakness, or according to the timbre (or quality) [Klangfarbe].

“Referring to our simile, this is about the same as if we throw two or more stones at different places into a calm pond. The wave lines cross each other, strengthen each other at some points, weaken each other at others, and the surface has a ruffled, hillocked aspect. But, nevertheless, our eye can detect the different systems of rings, and can trace them back to their several causes. If we succeed in transmitting with the galvanic current the oscillations of a sounding body to a distance, so that there another body is put to equally rapid and, in respect to each other, equally strong oscillations, the problem of ‘telephoning’ is solved.

“For then exactly the same phenomena of waves are called forth on the distant points as the ear receives at the place of origin; therefore they also must make the same impression. The ear will distinguish at the distant points, not only the single tones, according to their varying height and depth, but also to the proportionate force of the vibrations, and not only single melodies, but the performance of a whole orchestra; yes, even speech must be heard at the same time in places very distant from each other. Mr. Reis was the first one to prove by experiments the possibility of solving this problem. He has succeeded in constructing an apparatus to which he gives the name *Telephone*, and which enables one to reproduce tones, with the aid of electricity, at any given distance. Already, in October, 1861, he made rather successful experiments with a very simple, rudely-made apparatus, before a numerous audience at Frankfort. On July 4, of the present year, he presented an essentially improved apparatus at an assembly of the ‘Physical Union,’ which transmitted by closed doors and windows a melody sung, moderately loud, to a distance of about three hundred feet, so that it could be heard plainly.



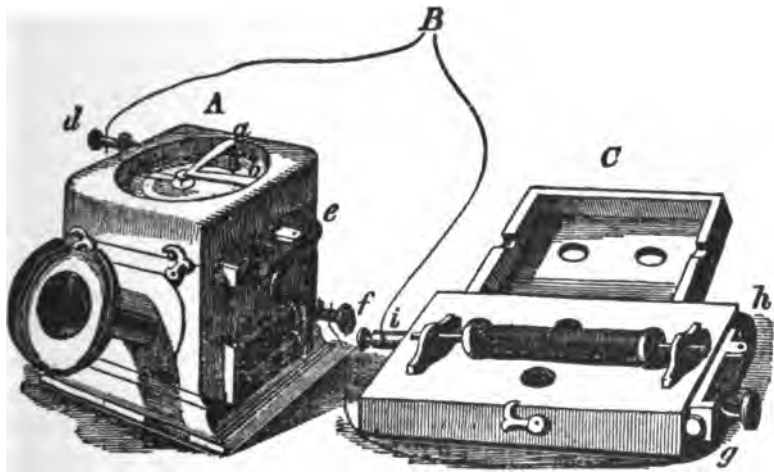

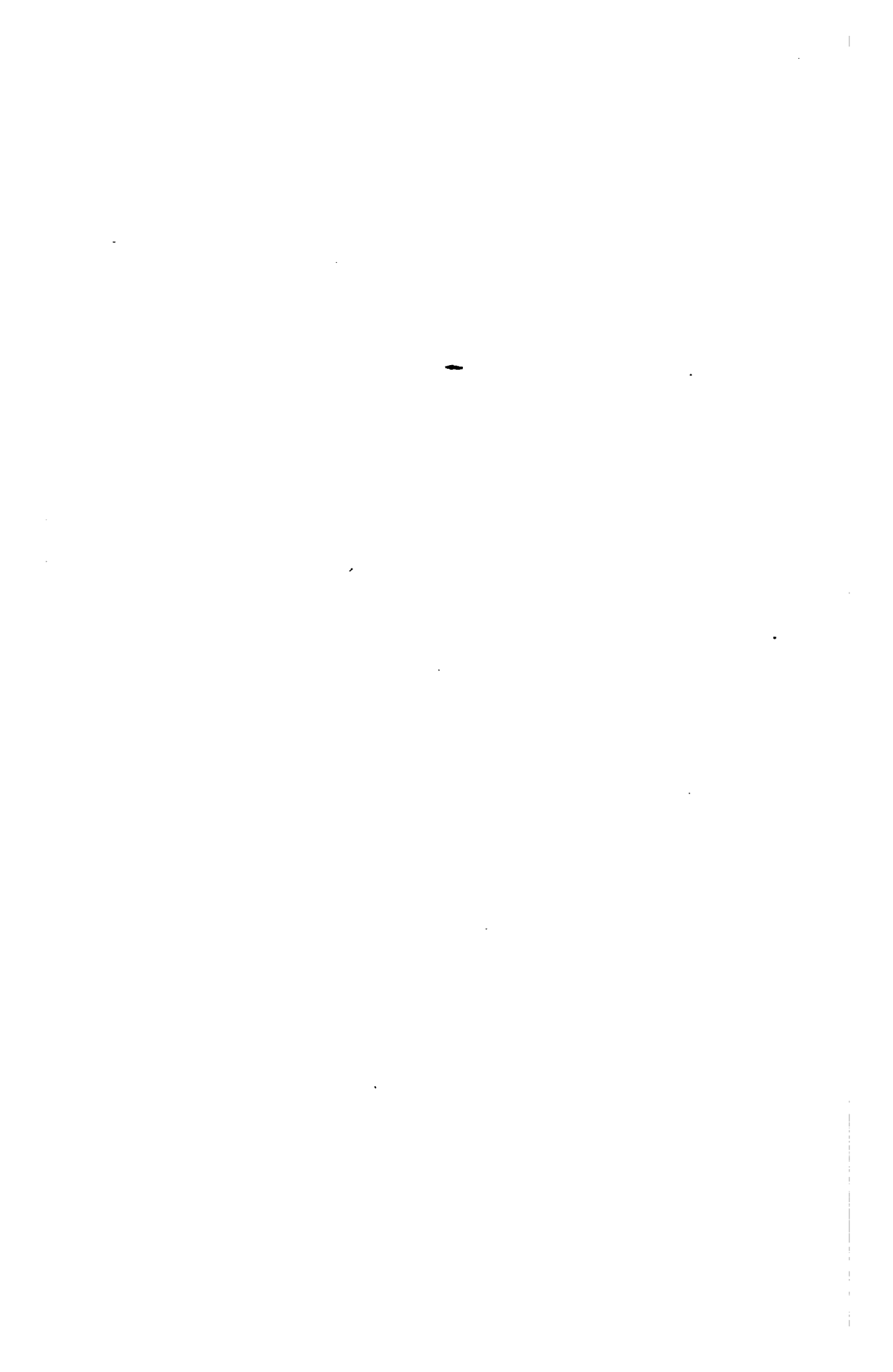

## Statement of the case.

"In order to give an opportunity to larger circles, especially to scientific men, to convince themselves of the efficiency of this essentially improved apparatus, Prof. Böttger, of Frankfurt-a-M., made lately (at an assembly of German physicists and doctors in Stettin, in the sectional meetings for natural sciences) several experiments which certainly would have been crowned with still more success if the hall in which the session was held had been located in a less noisy part of the city and filled with a less numerous audience.

"Although, for the present, we are not so far along as to be able to converse with a friend at a distance of several hundred miles, so much at least is certain, that with the aid of the telephone, songs of all kinds, melodies, especially in the middle registers, can be reproduced most clearly at unlimited distances. These wonderful results are obtained with the following simple apparatus, which we show here in one-fourth of its size.

"A small box A (the telephone proper), a kind of hollow cube has a mouthpiece S on the front side, and a somewhat smaller opening on the upper side of the box. The latter is closed with a fine membrane (skin from the intestines of a hog) tightly stretched. A narrow strip of platina *m*, connected with the screw post *d*, touches directly the membrane on its centre; a slender platina point *k*, attached to the angle *a b*, touches the strip of platina which rests on the membrane. If one sings into the mouthpiece S (by filling the same entirely with the mouth), the thin membrane vibrates and the attached platina strip receives likewise a vibrating motion, so that it is alternately pressed against and leaves the platina point *k*.

"From the binding post *d* which communicates with the platina strip resting on the membrane, a conducting wire is connected with one of the poles of a galvanic battery B (about three to four six-inch Bunsen elements), and then the electricity is led through a wire attached to the second pole of the battery to the distant station C; there at *i* it passes

## Statement of the case.

through a coil *ll* formed of copper wire covered with silk thread, then back again to screw *f*, and there to the platina point *k*. At every vibration of the membrane an interruption of the electric current [Unterbrechung des electrischen Stromes] takes place by the platina point parting from the platina strip.

“Within the wire coil at station C is a thin iron wire (a strong knitting needle) which is about ten inches long, and which, with its two ends projecting out of the coil for about two inches, each rests on two bridges of a sounding-box. This is the *reproducing* apparatus.

“At every interruption of the current [Unterbrechung des Stromes] in the coil the iron rod is made to vibrate. If the motions follow with a certain rapidity they produce a tone which is rendered audible by the sounding box. As the rate of the interruptions depends on the pitch of the tone that has been sung into the mouthpiece, the same tone is sounded with the same pitch from the sounding-box. The length of the circuit has no influence upon this. It is true the electric current loses force the farther it goes, but there is no reason why relays should not be employed, the same as in telegraphing, and with their aid any number of reproducing apparatuses be set into simultaneous vibrations. Mr. Reis has endeavored to give to his improved apparatus a form which should also be pleasing to the eye, so that it might fill worthily its place in any physical laboratory. He has applied, moreover, to the side of the telephone, as well as to the reproducing apparatus, a small telegraph arrangement, which is a very good addition for convenient experimenting. (It is indicated in the drawing by the letters *e f h g*). By alternately opening and closing the circuit with the key *e* or *h* the most varied signals may be given after mutual agreement; for instance, if one is ready for singing; if everything has been understood; whether one should stop singing or commence anew, etc.

“Mr. Reis himself manufactures the principal parts of the

## Statement of the case.

telephone, for which no small amount of physical knowledge and experience is necessary. The mechanician, Wilhelm Albert, at Frankfort, is charged with manufacturing the less important parts and the external outfit, as well as with the sale of the instrument at a low price."

## KUHNS DESCRIPTION OF REIS.

*Handbuch der Angewandten Electricitätslehre, Von Karl Kuhn, 1865, pp. 1017-1021.*

"The experiments made by Reis in Frankfurt-a-M, on the 26th October, 1861, have proved, however, that when the breaks of the current [Stromunterbrechungen] follow each other almost continuously and very quickly in a coil provided with a thin iron core, the iron wire can enter into longitudinal vibrations, and in this way be enabled to reproduce sounds of different pitch. An exact reproduction of the sounds does not take place, however, but only an imitation; for this reason it cannot be questioned here of transverse vibrations [transversal Schwingungen]. A phenomenon [Erscheinung] has otherwise been heard of, which belongs to the aforementioned class, in which the intensity and the timbre [Klang] of the sound accompanying it (the phenomenon) depend among other things on the strength of the current [Stromstärke] and on the number of breaks of the same, and in which, as it seems, the pitch of the tones also can vary under different circumstances. We can, however, hardly imagine by what arrangements it could be feasible to coax tones of any given height or depth out of an iron or metal tube split on one side, while it (the tube) is affected by the alternate currents of an induction apparatus the coil (Rolle) of which surrounds it. Yet the possibility cannot be controverted that the principle of Neef's circuit-breaker [Unterbrecher] might contribute to the solution of the problem in question. It has been employed for local purposes, either with or without modifications, in the study and investigation of acoustic phenomena. Thus Petrina has used the principle of Neef's

## Statement of the case.

circuit-breaker [Unterbrecher] for his electric harmonica in this way—that instead of the Neef hammer a little rod was chosen, the transverse vibrations of which rendered the tone. ‘There are four little rods of various lengths side by side, the motions of which are checked by means of levers managed by finger keys.’ That principle was used previously by Dove, in a modified manner, to set strained strings and elastic springs into acoustic vibrations of constant amplitude by means of an electric magnet, and, in this way, to be enabled to investigate constant tones. It appears from Legat’s published communications that ‘the ideas submitted by Ph. Reis of Friedrichsdorf in the Physical Society and in the meetings of the German Hochstift in Frankfurt-a-M, about the reproduction of sounds by means of electricity,’ referred to arrangements of a similar kind. Legat mentions in his paper all that has been done thus far towards the realization of that project, and we borrow from it that part only which throws some light on the construction of a telegraphic apparatus with which it is said to be possible to produce vibrations and make sounds in any desired manner, and through which the employment of electricity is said to make it feasible to bring forth at any given distance vibrations similar to the first produced ones, and in this way to reproduce at a certain place tones originally produced at another place.

“This apparatus is composed of a transmitter and of a receiver. (See cut *ante*, page 183.)

“The transmitter consists in a conical tube *a b* about 15 centimetres long, 10 centimetres at the front, 4 centimetres at the back opening; the choice of the material as well as a greater length is indifferent; a greater width, on the contrary, is disadvantageous; the surface of the interior must be as smooth as possible. The narrower back opening is closed by a membrane of collodion *o*, and on the middle of the circular surface formed by this membrane rests one end *c* of lever *c d*, the fulcrum of which is held by a support and remains connected with the metallic circuit. This lever, one arm *c e* of

## Statement of the case.

which must be considerably longer than  $e d$ , should be as light as possible, so as to follow easily the motions of the membrane, as an uncertain obedience [folgen] on part of lever  $c d$  would produce imperfect tones at the receiving station. In the state of rest, the contact  $d g$  is shut and a weak spring  $n$  holds the lever fast at rest. On the metallic support  $f$  which is connected with one of the poles of the battery is a spring  $g$ , with a contact which touches the contact of lever  $c d$  at  $d$ , and the position of which is regulated by screw  $h$ ; over tube  $a b$  a disc must be placed which encircles the outer circumference of the tube closely, so that the efficacy of the apparatus may not be impaired through the effect of the air-waves coming round and striking against the rear end. This disc at right angles with longitudinal axis of the tube measures about fifty (?) centimetres in diameter. The receiver (Fig. 505) consists of an electro-magnet  $m m$  which rests on a sounding-board, and the coil of which is in connection with the metallic conductors, and with the ground. Opposite the electro-magnet is an armature connected with a lever as long as possible, but light and broad, which latter, with the armature, is fastened pendulum-like on the support  $k$ . Its motions are regulated through screw  $l$  or spring  $o$ . 'In order to increase the efficacy of the apparatus, this receiver can be placed in one focus of an ellipsoidal enclosing box of suitable size, while the ear of the hearer is placed at the other focus.' The working of the two apparatuses (the mode of connection of which is visible in the woodcuts), the transmitter being placed at one station, and the receiver at the other, is as follows: By speaking, singing, or the intromission of instrumental sounds into tube  $a b$ , in consequence of the condensation and rarefaction of the column of air, a motion of the membrane  $c$  corresponding to these changes is brought about. Lever  $c d$  follows the motions of the membrane, and opens or closes the circuit, according as a condensation or a rarefaction of the air inside takes place. As a consequence the electro-magnet  $m m$  (Fig. 505) is correspondingly demagnetized or

## Statement of the case.

magnetized, and the armature affixed to it (as well as the armature lever) is set into similar vibrations as the membrane of the transmitter. Through lever *i* connected with the armature, similar vibrations are communicated to the surrounding air and (the increasing effect of the sounding-board helping) the tones so produced finally reach the ear of the listener. In respect to the operations of this apparatus, the author remarks that the receiver does reproduce the exact number of the original vibrations, but that a reproduction of the original intensity has not yet been attained. For that reason, it is added, small differences in the vibrations are appreciated with difficulty, and in the practical experiments made thus far, it was possible to transmit with astonishing faithfulness chords, airs, etc., whilst in reading, speaking, etc., single words were more indistinctly heard. The apparatus just described is said to have been one of the constructions which Reis has used himself in his experiments. The underlying principles might give hopes of a farther improvement of the apparatus, but the telephone which, according to later reports, Reis has finally decided upon, has the disposition represented in Fig. 506, although the principle on which it is founded does not stand quite in harmony with the above-mentioned investigations of Wertheim, for instance.

“The telephone proper *A* consists of a hollow wooden box provided with a short sound-funnel *S*, and the upper side of which is open in the centre and covered over tightly with a delicate membrane. On the middle of the latter a thin platinum disc is fastened, from which on one side, a platinum strip establishes circuit connection with the contact of the key at *e*, from which place the metallic connection is effected with one end of the coil of a small electro-magnet provided with a spring armature, whilst the other end is in contact with screw *f*. The reproducing apparatus *C* set up at the receiving station consists simply of a coil about six inches long formed by winding six layers of copper wire; in the axis of the coil a thin iron wire ten inches long (a knitting



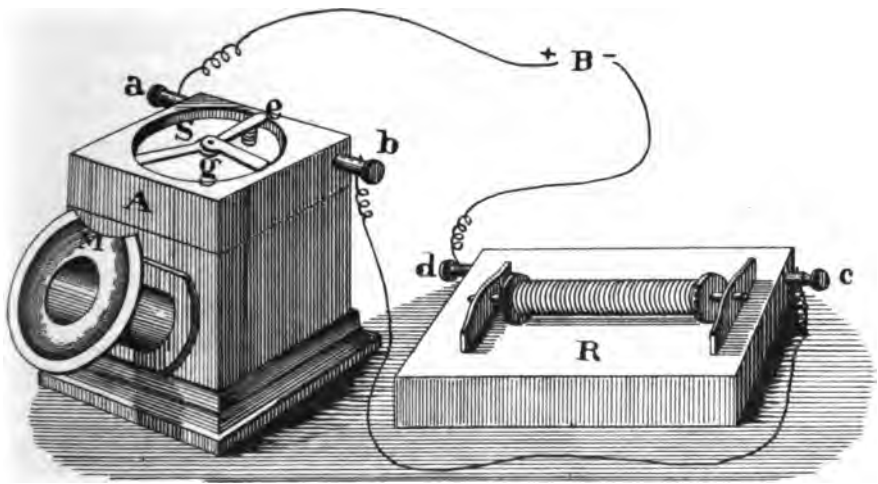



## Statement of the case.

needle), protruding out of each end of the coil about two inches, is so disposed that with its bridge-like supports it rests on a sounding-board. By means of screw *i* and of the key at *h g* the coil is thrown into the circuit and the connection of both apparatus is effected in the manner mentioned; a battery being placed at B, the course of the current is easily followed out. It can flow from B through *d c* and *c b* to *e* and *f*, and from here to the receiving station, and at *i* return to the battery, or it can start in the opposite direction according as *d* or *i* forms the starting point of the current. The circuit can be broken at will at each of the two stations by pressing the key lever, and a connection can be established thus in either direction; but the discontinuous currents which are to produce the sounding of the iron wire at C are obtained in this way: By singing or the blowing of instruments towards the sound-funnel S the membrane at A is made to vibrate; if this can be brought about, it will happen, as was demonstrated by the experiments, that the iron wire of the receiver assumes isochronal vibrations, and whenever this is the case, it reproduces the same tones which set the membrane to vibrating at the transmitting stations.

“My own experiments have demonstrated that every melody starting from *c* and embracing the entire extent of an average male voice, when sung into the telephone can be reproduced by the receiver at C. The timbre [Klang] or quality of the sounds thus reproduced is not pleasant—they are almost like the sounds of toy trumpets, at times also like the buzz of a fly caught in a spider’s web, and the like; yet the experiments of Reis are certainly interesting enough to challenge attention.

“A reproduction of the words spoken in the telephone with or without variation of pitch was audible at the receiver only in a corresponding noise [entsprechendes Geräusch], while a discriminate perception of single vocal sounds, syllables or words could not be had. According to communications made on this subject by Reis, he has suc-

## Statement of the case.

ceeded in reproducing the tones of organ pipes not covered, and those of a piano; in this latter case the transmitter was placed on the sounding-board of the piano."

Catalogue of J. Wilh. Albert, Mechanician at Frankfort-on-the-Main, 1866.

*Extract from preface.* "All instruments and apparatus will always be constructed according to the latest designs and improvements. In order that the construction may be better understood we have printed herein references where a description can be found as follows:

"*M.-P. Muller-Pouillet's Lehrbuch der Physik, vi Auflage.*"  
[Other books also named.]

*From body of catalogue.*

"839. Telephone of Reis for reproduction of tones by electricity with description, 21 fl.

"M.-P. Figs. 325-327. Pisco, Akustik, Fig. 60."

"840. The same in simpler design, fl. 14."

"Electricity, by Robert M. Ferguson, William and Robert Chambers, London and Edinburgh, 1867, p. 257.

## THE TELEPHONE.

"This is an instrument for telegraphing notes of the same pitch. Any noise producing a single vibration of the air, when repeated regularly a certain number of times in a second (not less than thirty-two), produces, as is well known, a musical sound. In Art. 115, we found that when a rod of iron was placed in a coil of insulated wire, and magnetized by a current being sent through the coil, it gave out a distinct tick when it was demagnetized by the stoppage of the current. A person when singing any note causes the air to vibrate so many times per second, the number varying with the pitch of the note he sings, the higher the note the greater being the number of vibrations. If we then, by any means, can get these vibrations to break a closed circuit in which the coil just mentioned is included,

## Statement of the case.

the note sung at one station can be reproduced, at least so far as pitch is concerned, at another. Reis's telephone (invented 1861) accomplishes this in the following way:

"AA (Fig. 141) is a hollow wooden box with two round holes in it, one on the top, the other in front. The hole at the top is closed by a piece of bladder *S*, tightly stretched on a circular frame; a mouthpiece *M* is attached to the front opening.

"When a person sings in at the mouthpiece, the whole force of his voice is concentrated on the tight membrane, which in consequence vibrates with the voice. A thin strip of platinum is glued to the membrane, and concentrated with the binding screw *a*, in which a wire from the battery *B* is fixed. A tripod *efg* rests on the skin. The feet *e* and *f* lie in metal cups on the circular frame over which the skin is stretched. One of them *f* rests in a cup containing mercury, and is connected with the binding screw *b*. The third foot, *g*, consisting of a platinum point, lies on the circular end of the strip of platinum just mentioned. This point, being placed on the centre of the oscillating membrane, acts like a hopper, and hops up and down with it. It is easy to understand how, for every vibration of the membrane, the hopper will be thrown up for the instant from connection with its support, and how the close circuit is thus broken at every vibration. The receiving apparatus *R* consists of a coil of wire placed in circuit, enclosing an iron wire, both being fixed on a sounding box. The connections of the various parts of the circuit are easily learned from the figure. Suppose a person to sing a note at the mouthpiece which produces three hundred vibrations a second, the circuit is broken at the bladder three hundred times, and the iron wire ticking at this rate gives out a note of the same pitch. The note is weak, and in quality resembles the sound of a toy trumpet. Dr. Wright uses a receiving apparatus of the following kind: The line current is made to pass through the primary coil of a small induction coil. In the secondary circuit he places

## Statement of the case.

two sheets of paper, silvered on one side, back to back, so as to act as a condenser. Each current that comes from the sending apparatus produces a current in the secondary circuit which charges and discharges the condenser, each discharge being accompanied by a sound like the sharp tap of a small hammer. The musical notes are rendered by these electric discharges, and are loud enough to be heard in a large hall."

From *The Manufacturer and Builder*, a monthly journal devoted to the advancement and diffusion of practical science, New York, May, 1869, Vol. 1., No. 5, pp. 129, 130.

## THE TELEPHONE, BY DR. VAN DER WEYDE.

"One of the most remarkable recent inventions connected with telegraphy is the telephone, an instrument which transmits directly the pitch of the sound by means of a telegraph wire—either an air wire or submarine cable—so that, for instance, when the operator at one end of the wire sings or plays on an instrument any tune, as 'Yankee Doodle' or 'Hail Columbia,' it will be heard and distinguished plainly at the other end. This invention may, in its present state, have no direct practical application, but be a mere scientific, although highly interesting, curiosity; but who can say that it does not contain the germ of a new method of working the telegraph, or some other useful practical purpose.

"The telephone is not the result of an accidental discovery, but of a thorough study of the laws of electro-magnetism and of sound. It is founded on the fact that the difference in pitch of different tones is caused by different velocities of vibrations of the elastic sounding body; which vibrations are transmitted to and by the air with exactly the same velocity, and from the air may be communicated to a properly-stretched membrane, like a piece of bladder or very thin sheet of India-rubber, stretched like a drumhead, which these also will vibrate with exactly the same velocity as the air and the original sounding body, be it the human voice,

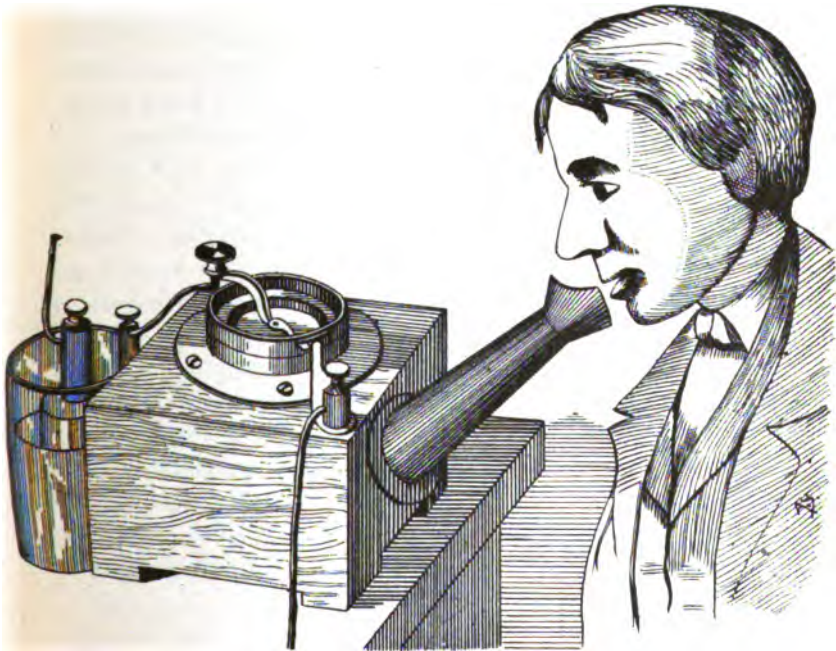
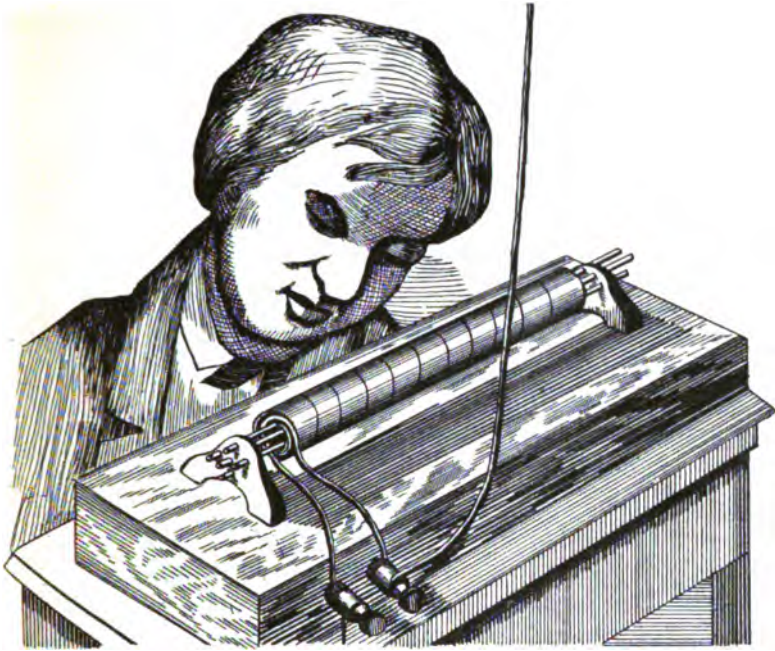

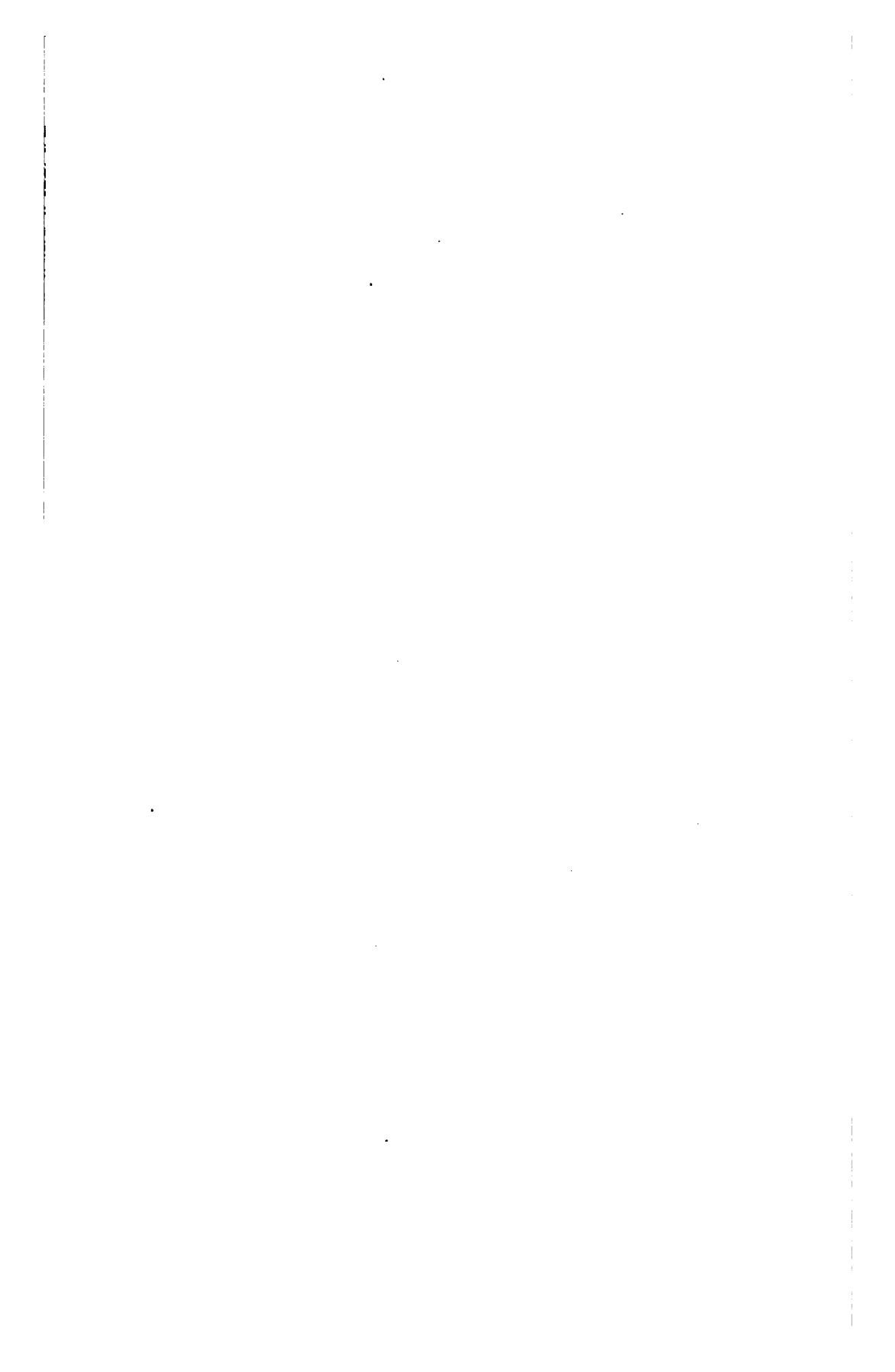



## Statement of the case.

organ pipe, string or any musical instrument. If, now, at the centre of this little drumhead there be attached a small disc of some metal not easily burned by electric currents—for instance, platinum—while at the same time a platinum point may, by means of a screw, be so adjusted as to come very nearly in contact with this small platinum disc, it is clear that, when the membrane is put in vibration, a succession of contacts between the disc and point will be produced, of which the number in each second will exactly correspond with the number of vibrations in each second of the sounding body or the tone produced by it. That part of the apparatus which serves to send off the tune or melody is represented in the illustration, Fig. 2. It consists simply of a square wooden box, provided at the side with a kind of mouthpiece similar to that of a speaking tube, and at the top with an opening, over which the membrane just mentioned has been stretched. The small piece of platinum attached to the centre of this little drumhead is, by means of a very flexible strip of some metal that conducts well, attached to one pole of the galvanic battery, of which only one cup is represented in the figure, although for a long wire several cups will, of course, be required. The reason why this connection near the platinum disc is a flat, thin and flexible strip is, that any rigidity would interfere with the freedom of vibration of the membrane to which it is attached. The point coming in contact with this small vibrating disc is connected with the ground wire, the other pole of the battery with the air wire or submarine cable. It is clear, from this explanation, that at every contact of the platinum point a wave of electricity will be sent over the wire, and as many waves in a second as there are contacts; and as there are as many contacts as there are vibrations in every second, the number of electric waves will be always exactly equal to the number of vibrations corresponding with the pitch of each tone, be it fifty, one hundred, two hundred or five hundred in every second.

## Statement of the case.

“The instrument in which this succession of waves is made audible at the other end of the telegraph wire is founded on the fact—first investigated by Professor Henry, of the Smithsonian Institute at Washington—that iron bars, when becoming magnetic by means of electric currents passing around them, become slightly elongated, and at the interruption of the current are at once restored to their original length. It is represented in the cut, Fig. 3, and consists of an elongated wooden box, of which the top is made of thin pine wood, similar to the sounding-board of a stringed musical instrument, to which are attached two bridges carrying long pieces of moderately thick and very soft iron wire, which, for nearly their whole length, are surrounded by a coil similar to the coil of the electro-magnets used in telegraphing. One end of this coil is attached to the telegraph wire, the other to the ground wire, as represented in the figure. At every instant that a contact is established at the station where the sound is produced, and a current wave thus transmitted, these wires will become magnetic, and consequently elongated; and they will be shortened again at every interruption of the current. And as these currents and interruptions succeed each other with the same velocity as the sound vibrations, the elongations and shortenings of the magnetized iron wires will succeed each other with exactly the same velocity, and consequently they will be thrown into a state of longitudinal vibrations corresponding with the original musical tone, which vibrations will then be communicated to the sounding-board in exactly the same manner as is the case with the vibrations of the strings in all stringed instruments, thus becoming more audible at the receiving station.

“It is clear, from the foregoing explanations, that no quality of tone can be transmitted. Much less can articulate words be sent, notwithstanding the enthusiastic prediction of some persons, who, when they first beheld this apparatus in operation, exclaimed that now we would talk directly through the wire. It is from its nature able to transmit

## Statement of the case.

only pitch and rhythm—consequently melody, and nothing more. No harmony nor different degrees of strength or other qualities of tone can be transmitted. The receiving instrument, in fact, sings the melodies transmitted, as it were, with its own voice, resembling the humming of an insect, regardless of the quality of the tone which produces the original tune at the other end of the wire.

“This instrument is a German invention, and was first exhibited in New York, at the Polytechnic Association of the American Institute, by Dr. Van der Weyde. The original sounds were produced at the farther extremity of the large building (the Cooper Institute), totally out of hearing of the Association; and the receiving instrument, standing on the table of the lecture-room, produced with its own rather nasal twang the different tunes sung at the other end of the line, rather weakly, it is true, because of the weak battery used, but very distinctly and correctly.”

*Das Buch der Erfindungen, Gewerbe und Industrien, Leipzig, 1872.*

[Book of Inventions, Trades and Industries.]

## TELEPHONY.

“It sounds more than wonderful when the possibility is asserted of carrying on a conversation with another person at a distance of hundreds of miles through the electric telegraph wire, so that he can hear with his bodily ear, our voice with all its peculiarities, that he should hear the melody we are singing, and that he should feel, when we laugh, precisely as if he was standing alongside of us.

“But this possibility has, to a certain degree, already become to be a fact.

“The master teacher, Reis, in Frankfurt-on-the-Main, had the good idea to make of the electro-magnetic telegraph, ‘which has heretofore been an eye reaching over many lands,’ an ear which should reach full as far.

“In this strange organ of hearing, the electro-magnetic

## Statement of the case.

apparatus takes the part of those bones of the ear which carry the commotion from one membrane to another, and the only difference between the cavity of the ear and the union of two such stations is that in one case we are made sensible of the striking of the sound-waves against the ear-drum by means of a lever, and in the other by means of the commotion of an iron rod. \* \* \* \* \*

“As early as October, 1861, Reis had made successful trials with his apparatus. A melody sung with a medium loud voice was reproduced perfectly at a distance of one hundred metres. Although the problem of ‘far speaking’ may so far only be considered solved in theory, and the apparatus has not yet that perfection which would make it possible for a speaker to interest large gatherings at numerous distant parts of the earth, it is nevertheless interesting enough to be described in this place.”

From *Scientific American*, New York, March 4, 1876.

*The Invention of the Telephone*, by P. H. Van der Weyde, M.D.

“In connection with Mr. Gray’s application of the telephone to the simultaneous transmission of several different telegraphic messages over one wire at the same time, and his paper read before the American Electrical Society (published on p. 92, *Scientific American*, Supplement for Feb. 5), it may be interesting for the readers of this paper to obtain some information in regard to the invention of the telephone by Reuss. As mentioned in the article above referred to, Page and Henry observed that, by rapid magnetization and demagnetization, iron could be put into vibrations isochronic with the interruptions of the current, and later, Marian experimented extensively in this direction, while Wertheim made a thorough investigation of the subject, which induced Reuss, of Friedrichsdorf, near Hamburg, Germany, to apply this principle to the transmission of musical tones and melodies by telegraph; and he contrived an apparatus which we represent in the engravings.

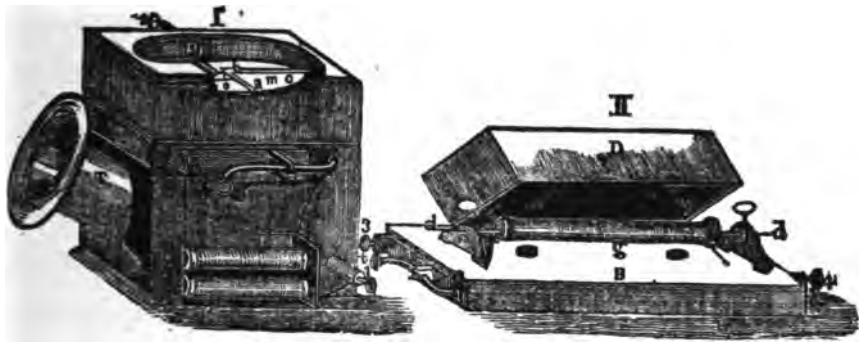

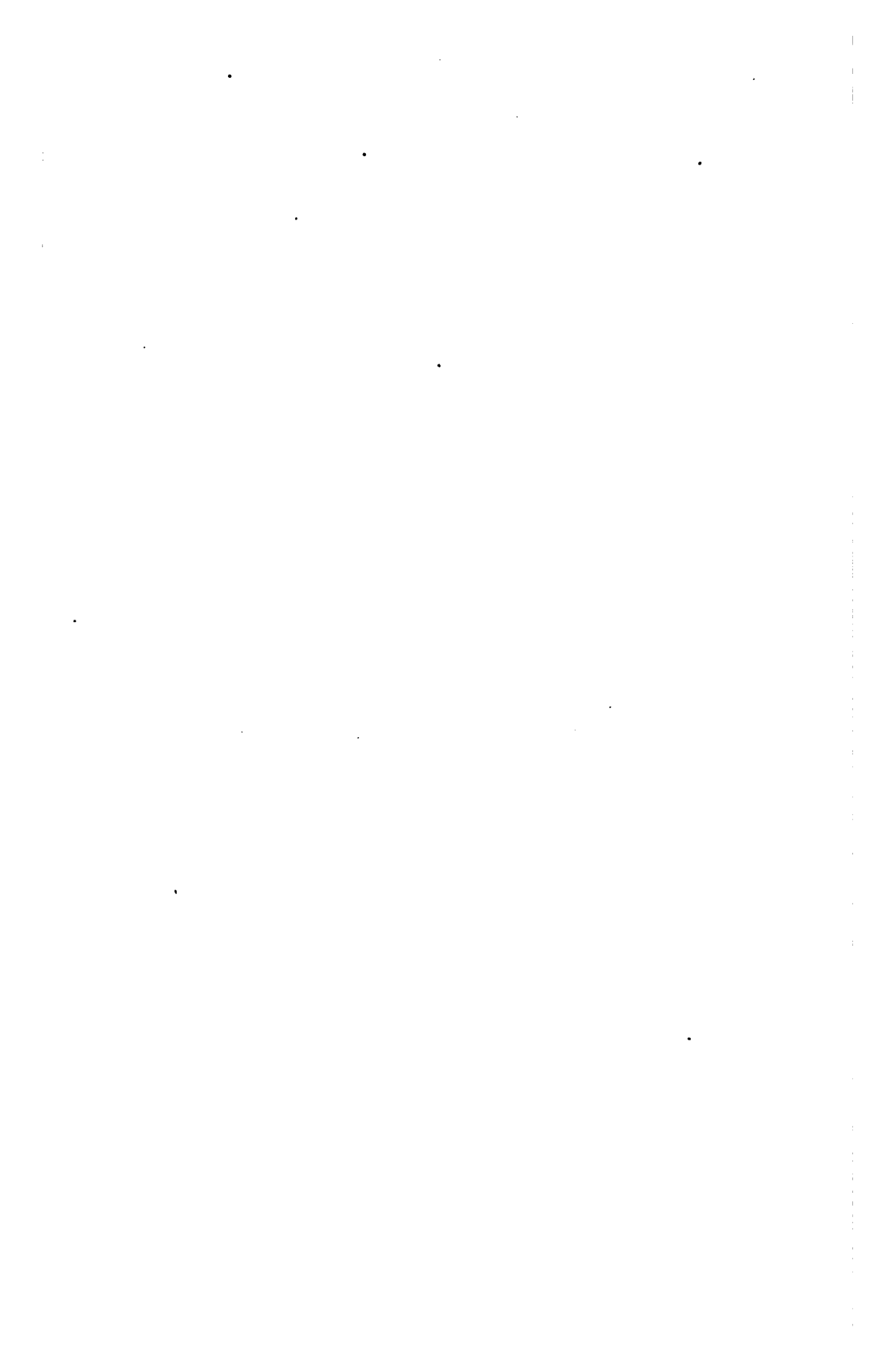

## Statement of the case.

“The telephone of Reuss consists of two parts, the transmitting and receiving instrument. Fig. I represents the former, and is placed at the locality where the music is produced; Fig. II, the latter, is placed at the station where the music is to be heard, which may be at a distance of 100, 200 or more miles; in fact, as far as the battery used can carry the current, while the two instruments are connected with the battery and the telegraph wire in the usual manner. One pole of the battery is connected with the ground-plate, the other with the screw, marked 2 in our Fig. I, and thence over a thin copper strip *n*, with the platinum disc *o* attached to the centre of the membrane stretched in the large top opening of the hollow and empty box *K*, intended to receive and strengthen the vibrations of the air, produced by singing before the funnel-shaped short tube attached to the opening in *T*. Over the platinum disc *c*, attached to the elastic membrane, is a platinum point attached to the arms *b c* and *b K*, while a set-screw brings this point in slight contact with the platinum disc mentioned. A part of the box is represented as broken and removed, in order to show the internal construction. The strip *a b c* is connected with the end *s* of the switch *t s*, and the screw-connection 1, at the lower right-hand corner, and also through the telegraph wire to the instrument, Fig. 2, at the receiving station, which may be situated at a distance of many miles. Here the current enters by the screw connection 3, and passes through the spiral *g*, surrounding the soft iron wire *d d*, of the thickness of a knitting-needle, and leaves the apparatus at the screw-connection 4, whence it obtains access to the ground-plate, and so passes, through the earth, back to the battery. The spiral and iron wire *d d*, is supported on a hollow box *B*, of thin board, while a cover *D*, of the same material is placed on top, all intended to strengthen the sound produced by the vibrations which the interruption of the current caused in the iron wire *d d*, so as to make these vibrations more audible by giving a large vibratory surface, in the same way that

## Statement of the case.

the sounding-board of a pianoforte strengthens the vibrations of the air caused by the strings, and makes a very weak sound quite powerful.

“If a flute be played before the opening T, or if a voice be singing there, the vibration of the air inside the box K causes the membrane *m* to vibrate synchronically, and this causes the platinum disc *o* to move up and down with corresponding frequency. At every downward motion the contact of this disc with the platinum point, under *b*, is broken, and therefore the current is interrupted as rapidly as the vibrations occur. Let, for instance, the note C be sounded; this note makes sixty-four full vibrations in a second, and we have, therefore sixty-four interruptions of the electric current, which interruption will at once be transmitted through the telegraph lines to the receiving instrument, and put the bar *d d*, into exactly similar vibrations, making the very same tone C audible, and so on for all other rates of vibration. It is clear that in this way not only the rhythm of music can be transmitted (and this can be done by the ordinary telegraph), but the very tones, as well as the relative durations and the rests between them, can thus be sent, making a full and complete melody. The switch *t s*, Fig. I, is intended, in connection with a similar one in Fig. II. to communicate between the stations, with the help of the electro-magnet E, to ascertain if station, Fig. II, is ready to receive the melodies; then it gives the signal, by manipulating the switch, which is received by the attraction of the armature A, the latter arrangement being a simple Morse apparatus attached to the telephone.

“Professor Heisler, in his *Lehrbuch der Technischen Physik* (3d edition, Vienna, 1866), says in regard to this instrument: ‘The telephone is still in its infancy; however, by the use of batteries of proper strength, it already transmits, not only single musical tones, but even the most intricate melodies, sung at one end of the line to the other, situated at a great distance, and makes them perceptible there with all the



## Statement of the case.

desirable distinctness.' After reading this account in 1868, I had two such telephones constructed, and exhibited them at the meeting of the Polytechnic Club of the American Institute. The original sounds were produced at the further extremity of the large building (the Cooper Institute), totally out of hearing of the Association, and the receiving instrument, standing on the table in the lecture-room, produced (with a peculiar and rather nasal twang) the different tunes sung into the box K, at the other end of the line; not powerfully, it is true, but very distinctly and correctly. In the succeeding summer I improved the form of the box K, so as to produce a more powerful vibration of the membrane, by means of reflections effected by curving the sides; I also improved the receiving instrument by introducing several iron wires in the coil, so as to produce a stronger vibration. I submitted these, and some other improvements, to the meeting of the American Association for the Advancement of Science, and on that occasion (now seven years ago) expressed the opinion that the instrument contained the germ of a new method of working the electric telegraph, and would undoubtedly lead to further improvements in this branch of science, needing that only a competent person give it his undivided attention, so as to develop out of it all that it is evidently capable of producing.

"Before leaving the subject, I wish to draw special attention to the fact that the merits of this invention consist chiefly in the absence of musical instruments, tuning forks, or their equivalents, for producing the tones; any instrument will do,—flute, violin, human voice, etc. If the aerial vibrations are only connected into the box, Fig. I, the apparatus will send the pitch as well as the duration of the different tones, with the rests between, therefore not only transmitting perfect rhythm, but a complete melody, with its long and short notes. The two parts of the apparatus may even be connected each to a separate pianoforte: and if this were done in a proper manner, a melody played on the piano-

## Statement of the case.

forte connected with the transmitting instrument, Fig. I, would be heard in the pianoforte at a great distance connected with the receiving instrument, Fig. II.

“The defendants in these actions all alleged that Bell’s invention or discovery, mentioned in his letters patent were not new or original, but had been, prior to his alleged invention or discovery, invented or discovered by other persons to whom letters patent had been issued; among whom were Elisha Gray, to whom several patents had been issued; Cromwell Fleetwood Varley, to whom English patents had been issued, and others, a long list of whom are mentioned in the answer of the Clay Commercial Telephone Company.

“In this Court it is claimed, and the charge made in briefs for the Overland and Drawbaugh Companies, that Bell’s application, as originally filed in the Patent Office, did not contain his present 4th claim or any description of the variable resistance method, and that all which now appears in his specification on that subject, including the 4th claim, were surreptitiously interpolated afterwards. Bell’s application was filed February 14, 1876, and during the same day, Elisha Gray filed a caveat in which he claimed as his invention the art of transmitting vocal sounds telegraphically through an electric circuit. The charge was made in the printed brief of Mr. Hill (as stated in the opinion in this case) that ‘Mr. Bell’s attorneys had an underground railroad in operation between their office and Examiner Wilbur’s room in the Patent Office, by which they were enabled to have unlawful and guilty knowledge of Gray’s papers as soon as they were filed in the Patent Office,’ and ‘that an important invention and a claim therefor were bodily interpolated into Bell’s specification between February 14, 1876, and February 19, 1876,’ in consequence of knowledge of Gray’s caveat improperly obtained. The following is a copy of Gray’s said caveat referred to in said charge:

## Statement of the case.

ELISHA GRAY, OF CHICAGO, ILLINOIS.

TRANSMITTING VOCAL SOUNDS TELEGRAPHICALLY.

Gray's caveat; filed February 14, 1876.

*"To all whom it may concern:*

"Be it known that I, ELISHA GRAY, of Chicago, in the county of Cook, and State of Illinois, have invented a new *Art of transmitting vocal sounds telegraphically*, of which the following is a specification:

"It is the object of my invention to transmit the tones of the human voice through a telegraphic circuit, and reproduce them at the receiving end of the line, so that actual conversations can be carried on by persons at long distances apart.

"I have invented and patented methods of transmitting musical impressions or sounds telegraphically, and my present invention is based upon a modification of the principle of said invention, which is set forth and described in letters patent of the United States, granted to me July 27, 1875, respectively numbered 166,095 and 166,096, and also in an application for letters patent of the United States, filed by me February 23, 1875.

"To attain the objects of my invention, I devised an instrument capable of vibrating responsively to all the tones of the human voice, and by which they are rendered audible.

"In the accompanying drawings I have shown an apparatus embodying my improvements, in the best way now known to me, but I contemplate various other applications, and also changes in the details of construction of the apparatus, some of which would obviously suggest themselves to a skilful electrician, or a person versed in the science of acoustics, on seeing this application.

"Fig. 1 represents a vertical central section through the transmitting instrument.

"Fig. 2, a similar section through the receiver; and Fig. 3 a diagram representing the whole apparatus.

## Statement of the case.

“My present belief is, that the most effective method of providing an apparatus capable of responding to the various tones of the human voice is a tympanum, drum or diaphragm, stretched across one end of the chamber, carrying an apparatus for producing fluctuations in the potential of the electric current, and consequently varying in its power.

“In the drawings, the person transmitting sounds is shown as talking into a box or chamber, A, across the outer end of which is stretched a diaphragm, *a*, of some thin substance, such as parchment or gold beaters' skin, capable of responding to all the vibrations of the human voice, whether simple or complex. Attached to this diaphragm is a light metal rod A', or other suitable conductor of electricity, which extends into a vessel, B, made of glass or other insulating material, having its lower end closed by a plug, which may be of metal, or through which passes a conductor, *b*, forming part of the circuit.

“This vessel is filled with some liquid possessing high resistance, such for instance, as water, so that the vibrations of the plunger or rod A', which does not quite touch the conductor *b*, will cause variations in resistance, and, consequently, in the potential of the current passing through the rod A'.

“Owing to this construction, the resistance varies constantly, in response to the vibrations of the diaphragm, which, although irregular, not only in their amplitude but in rapidity, are nevertheless transmitted, and can, consequently, be transmitted through a single rod, which could not be done with a positive make and break of the circuit employed, or where contact points are used.

“I contemplate, however, the use of a series of diaphragms in a common vocalizing chamber, each diaphragm carrying an independent rod, and responding to a vibration of different rapidity and intensity; in which case contact points mounted on other diaphragms may be employed.

“The vibrations thus imparted are transmitted through

**ELISHA GRAY**  
**INSTRUMENTS FOR TRANSMITTING AND**  
**RECEIVING VOCAL SOUNDS TELEGRAPHICALLY**  
**CAVEAT FILED FEBRUARY 14<sup>th</sup> 1876**

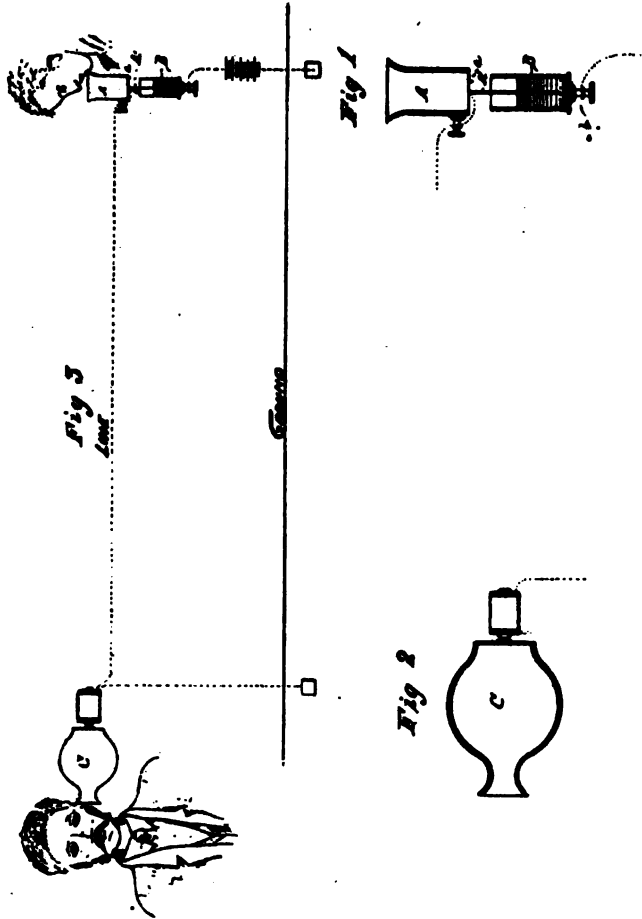

**WITNESSES.**

*H. A. Smith*  
*J. Hill*

**INVENTOR,**

*Elisha Gray*



## Statement of the case.

an electric circuit to the receiving station, in which circuit is included an electro-magnet of ordinary construction, acting upon a diaphragm to which is attached a piece of soft iron, and which diaphragm is stretched across a receiving vocalizing chamber *c*, somewhat similar to the corresponding vocalizing chamber *A*.

“The diaphragm at the receiving end of the line is thus thrown into vibration corresponding with those at the transmitting end, and audible sounds or words are produced.

“The obvious practical application of my improvement will be to enable persons at a distance to converse with each other through a telegraphic circuit, just as they now do in each other’s presence, or through a speaking tube.

“I claim, as my invention, the art of transmitting vocal sounds or conversations telegraphically through an electric circuit.”

Witnesses:

ELISHA GRAY.

WILLIAM J. PEYTON,

WILLIAM D. BALDWIN.

One item of evidence, on which the charge of the fraudulent interpolation into Bell’s specifications above mentioned is rested, is a paper handed by Bell to George Brown, of Toronto, describing his invention which was intended to be used in England to secure a British patent in which what is now claimed to be an interpolation in the American application is not to be found. The following is a copy of such paper:

*Bell’s George-Brown specification, No. V.*

ALEXANDER GRAHAM BELL, OF SALEM, ASSIGNOR  
TO HIMSELF AND THOMAS SANDERS, OF HAVER-  
ILL, AND GARDINER G. HUBBARD, OF CAM-  
BRIDGE, MASSACHUSETTS.

*To all whom it may concern:*

Be it known that I, ALEXANDER GRAHAM BELL, of Salem, Massachusetts, have invented certain new and useful im-

## Statement of the case.

provements in telegraphy, of which the following is a specification :

In [another application for] letters patent granted to me [in] April 6, 1875 (No. 161,739), I have described a method of, and apparatus for, transmitting two or more telegraphic signals simultaneously along a single wire by the employment of transmitting instruments, each of which occasions a succession of electrical impulses differing in rate from the others; and of receiving instruments each tuned to a pitch at which it will be put in vibration to produce its fundamental tone by one only of the transmitting instruments; and of vibratory circuit-breakers operating to convert the vibratory movement of the receiving instrument into a permanent make or break (as the case may be) of a local circuit in which is placed a Morse sounder register, or other telegraphic apparatus. I have also therein described a form of autograph telegraph based upon the action of the above-mentioned instruments.

In illustration of my method of multiple telegraphy I have shown in the [application] PATENT aforesaid, as one form of transmitting instrument an electro-magnet having a steel spring armature which is kept in vibration by the action of a local battery. This armature in vibrating makes and breaks the main circuit, producing an intermittent current upon the line-wire. I have found, however, that upon this plan the limit to the number of signals that can be sent simultaneously over the same circuit is very speedily reached; for when a number of transmitting instruments, having different rates of vibration, are simultaneously making and breaking the same circuit, the effect upon the main line is practically equivalent to one continuous current.

My present invention consists in the employment of a vibratory or undulat[ing]ORY current of electricity in place of a merely intermittent one; and of a method of, and apparatus for, producing electrical undulations upon the line-wire. The advantages [claimed for the undulatory current over



## Statement of the case.

the] I CLAIM TO DERIVE FROM THE USE OF AN UNDULATORY CURRENT IN PLACE OF A merely intermittent one, are—

1. That a very much larger number of signals can be transmitted simultaneously over the same circuit.

2. That a closed circuit and single main battery may be employed.

3. That communication in both directions is established without the necessity of using special induction-coils.

4. And that—as the circuit is never broken—a spark-arrester becomes unnecessary.

It has long been known that when a permanent magnet is caused to approach the pole of an electro-magnet a current of electricity is induced in the coils of the latter, and that when it is made to recede a current of opposite polarity to the first appears upon the wire. When, therefore, a permanent magnet is caused to vibrate in front of the pole of an electro-magnet, an undulatory current of electricity is induced in the coils of the electro-magnet, the undulations of which correspond in rate of succession to the vibrations of the magnet, in polarity to the direction of its motion, and in intensity to the amplitude of its vibration. That the difference between an undulatory and an intermittent current may be more clearly understood, I shall describe the condition of the electrical current when THE ATTEMPT IS MADE TO TRANSMIT two musical notes [of different pitch are] simultaneously [transmitted along the same wire] FIRST UPON THE ONE PLAN AND THEN UPON THE OTHER. Let the interval between the two sounds be a major third. Then their rates of vibration are in the ratio of 4: 5.

Now, when the intermittent current is used the circuit is made and broken four times by one TRANSMITTING instrument in the same time that five makes and breaks are caused by the other [instrument].

A and B (Figs. I, II, and III) represent the intermittent currents produced; four impulses of A being made in the same time as five impulses of B, *c c c*, etc., show where and

## Statement of the case.

for how long time the circuit is made, and *d d d*, etc., indicate the duration of the breaks of the circuit.

The line  $A + B$  shows the total effect upon the current when the transmitting instruments for  $A$  and  $B$  are caused [to] simultaneously to make and break the same circuit. The resultant effect depends very much upon the duration of the make relatively to the break. In Fig. I the rate is as 1: 4; in Fig. II as 1: 2; and in Fig. III the makes and breaks are of equal duration.

The combined effect  $A + B$  (Fig. III) is very nearly equivalent to a continuous current.

When many transmitting instruments of different [pitch] RATES OF VIBRATION are simultaneously making and breaking the same circuit, the current upon the main line [loses altogether its intermittent character and] becomes for all practical purposes continuous.

[But now] next consider the effect when an undulatory current is employed.

Electrical undulations, induced by the vibration of a body capable of inductive action, can be represented graphically without error by the same sinusoidal curve, which express the vibration of the inducing body itself, and the effect of its vibration upon the air.

For, as above stated, the rate of oscillation in the electrical current corresponds to the rate of vibration of the inducing body; that is, to the pitch of the sound produced; the intensity of the current varies with the amplitude of vibration; that is, with the loudness of the sound; and the polarity of the current corresponds to the direction of the motion of the vibrating body; that is, to the condensations and rarefactions of air produced by the vibration. Hence the sinusoidal curve  $A$  or  $B^*$  (Fig. IV) represents graphically the electrical undulations induced in a circuit by the vibration of a body capable of inductive action.

\* " $A$  or  $B$ " interlined in original.

Words in small capitals interlined in original.

Words in square brackets [ ] erased in original.

## Statement of the case.

The horizontal line (*a b d f*) represents the zero of current; the elevations (*c c c*) indicate impulses of positive electricity; the depressions (*e e e*) show impulses of negative electricity; the vertical distance (*cd* or *ef*) of any [point on] PORTION OF the curve from the zero line expresses the intensity of the positive or negative impulse at the part OBSERVED; and the horizontal distance (*a a*) indicates the duration of the electrical oscillation.

The vibrations represented by the sinusoidal curves A and B (Fig. IV) are in the ratio aforesaid, of 4 : 5; that is, four oscillations of A are made in the same time as five oscillations of B.

The combined effect of A and B, when induced simultaneously on the same circuit, is expressed by the curves A + B (Fig. IV), which is the algebraical sum of the sinusoidal curve and B. This curve (A + B) also indicates the actual motion of the air when the two musical notes considered are sounded simultaneously.

Thus, when electrical undulations of different rates are simultaneously induced in the same circuit, an effect is produced exactly analogous to that occasioned in the air by the vibration of the inducing bodies.

Hence the co-existence [of] UPON a telegraphic circuit of electrical vibrations of different pitch is manifested—not by the obliteration of the vibratory character of the current, but by peculiarities in the shapes of the electrical undulations; or, in other words, by peculiarities in the shapes of the curves which represent those undulations.

[Undulatory currents of electricity may be produced in many other ways than that described above, but all the methods depend for effect upon the vibration or motion of bodies capable of inductive action.]

There are many [other] ways of producing undulatory currents of electricity, but all of them depend for effect upon the vibration or motion of bodies capable of inductive action.

## Statement of the case.

A few of the methods that may be employed I shall here specify.\*

[I shall specify a few of the methods that may be used to produce the effect.]

When a wire through which a continuous current of electricity is passing is caused to vibrate in the neighborhood of another wire, an undulatory current of electricity is induced in the latter.

When a cylinder upon which are arranged bar-magnets is made to rotate in front of the pole of an electro-magnet, an undulatory current is induced in the coils of the electro-magnet.

Undulations may also be caused in a continuous voltaic current by the vibration or motion of bodies capable of inductive action, or by the vibration of the conducting wire itself in the neighborhood of such bodies.

In illustration of the method of creating electrical undulations, I shall show and describe one form of apparatus for producing the effect.

I prefer to employ for this purpose an electro-magnet (A, Fig. 5) having a coil upon only one of its legs (6). A steel spring armature (c) is firmly clamped by one extremity to the uncovered leg (d) of the magnet, and its free end is allowed to project above the pole of the covered leg. The armature (c) can be set in vibration in a variety of ways (one of which is by wind), and in vibrating it yields a musical note of a certain definite pitch.

When the instrument (A) is placed in a voltaic circuit (*g b e f g*) the armature (c) becomes magnetic, and the polarity of its free end is opposed to that of the magnet underneath. So long as the armature (c) remains at rest no effect is produced upon the voltaic current, but the moment it is set in vibration to produce its musical note a powerful inductive action takes place, and electrical undulations traverse the

\* This paragraph (four lines) interlined in original.

Words in square brackets [ ] erased in original.

Words in small capitals interlined in original.

## Statement of the case.

circuit (*g b e f g*). The vibratory current passing through the coils of the distant electro-magnet (*f*) causes vibration in its armature (*h*), when the armatures (*c h*) of the two instruments (A I) are normally in unison with one another; but the armature (*h*) is unaffected by the passage of the undulatory current when the pitches of the two instruments (A I) are different [from one another].

A number of instruments may be placed upon a telegraphic circuit (as in Fig. VI). When the armature of any one of the instruments is set in vibration all the other instruments on the circuit which are in unison with it respond, but those which have normally a different rate of vibration remain silent. Thus if A (Fig. VI) is set in vibration, the armatures of A<sup>1</sup> and A<sup>2</sup> will vibrate also, but all the others on the circuit remain still. So also if B<sup>1</sup> is caused to emit its musical note, the instruments B B<sup>2</sup> respond. They continue sounding so long as the mechanical vibration of B<sup>1</sup> is continued, but become silent the moment its motion stops. The duration of the sound may be made to signify the dot or dash of the Morse alphabet, and thus a telegraphic dispatch can be transmitted by alternately interrupting and renewing the sound.

When two or more instruments of different pitch are simultaneously caused to vibrate, all the instruments of corresponding pitches upon the circuit are set in vibration, each responding to that one only of the transmitting instruments with which it is in unison. Thus the signals of A are repeated by A<sup>1</sup> and A<sup>2</sup>, but by no other instruments upon the circuit; the signals of B<sup>2</sup> by B and B<sup>1</sup>, and the signals of C<sup>1</sup> by C and C<sup>2</sup>, whether A, B<sup>2</sup>, and C<sup>1</sup> are successively or simultaneously set in vibration.

Hence, by these instruments, two or more telegraphic signals or messages may be sent simultaneously over the same circuit without interfering with one another.

I desire here to remark that there are many other uses to which these instruments may be put, such as the simulta-

## Statement of the case.

neous transmission of musical notes differing in loudness as well as in pitch, and the telegraphic transmission of noises or sounds of any kind.

When the armature *c* (Fig. V) is mechanically set in vibration, the armature *h* responds not only in pitch but in loudness. Thus when *c* vibrates with little amplitude, a very soft musical note proceeds from *h*, and when *c* vibrates forcibly the amplitude of vibration of *h* is considerably increased, and the sound becomes louder. So if A and B (Fig. VI) are sounded simultaneously (A loudly and B softly) the instruments A<sup>1</sup> A<sup>2</sup> repeat loudly the signals of A, and the instruments B<sup>1</sup> B<sup>2</sup> repeat gently those of B.

One of the ways in which the armature (*c*), Fig. VI, may be set in vibration has been stated above to be by wind. Another mode is shown [by] IN Fig. VII [which], WHEREBY motion can be imparted to the armature by means of the human voice or by the tones of a musical instrument.

The armature *c* (Fig. VII) is fastened loosely by one extremity to the uncovered pole (*d*) of the electro-magnet (*b*), and its other extremity is attached to the centre of a stretched membrane (*a*). A cone, A, is used to converge sound vibrations upon the membrane. When a loud sound is uttered in the cone the membrane (*a*) is set in vibration, the armature (*c*) is forced to partake of the motion, and thus electrical undulations are caused upon the circuit E *b e f g*. These undulations are similar in form to the air vibrations caused by the sound—that is, they [are] CAN BE represented graphically by similar curves. The undulatory current passing through the electro-magnet (*f*) influences [the] ITS armature (*h*) to copy the motion [s] of the armature (*c*). A similar sound to that uttered into A is then heard to proceed from L.

[Having described my invention, what I claim and desire to secure by letters patent is as follows:

1. A system of telegraphy in which the receiver is set in vibration by the employment of (vibratory or) undulatory currents of electricity.

## Statement of the case.

2. The method of creating an undulatory current of electricity by the vibration of a permanent magnet or other body capable of inductive action.

3. The method of inducing undulations in a continuous voltaic current by the vibration or motion of bodies capable of inductive action.

4. The method of, and apparatus for, transmitting vocal or other sounds telegraphically by (inducing in a continuous voltaic circuit) CAUSING ELECTRICAL undulations similar in form to the vibrations of the air accompanying said vocal or other sounds, the whole for operation substantially as **HEREIN** shown and described.]

In this specification the three words "oscillation," "vibration," and "undulation" are used synonymously.

By the term "body capable of inductive action," I mean a body which, when in motion, produces dynamical electricity. I include in the category of bodies capable of inductive action brass, copper, and other metals, as well as iron and steel.

Having described my invention, what I claim and desire to secure by letters patent, is as follows:

1. A system of telegraphy in which the receiver is set in vibration by the employment of undulatory currents of electricity.

2. The combination of a permanent magnet or other body capable of inductive action with a closed circuit, so that the vibration of the one shall produce electrical undulations in the other or in itself.

Thus (a.) The permanent magnet or other body capable of inductive action may be set in vibration in the neighborhood of the conducting wire forming the circuit.

(b.) The conducting wire may be set in vibration in the neighborhood of the permanent magnet.

(c.) The conducting wire and the permanent magnet may both simultaneously be set in vibration in each other's neighborhood.

Words in small capitals interlined in original.

Words in square brackets [ ] erased in original.

## Statement of the case.

borhood; and in any or all of these cases electrical undulations will be produced upon the circuit.

3. The method of producing undulations in a continuous voltaic current by the vibration or motion of bodies capable of inductive action, or by the vibration or motion of the conducting wire itself in the neighborhood of such bodies.

4. The method of, and apparatus for, transmitting vocal or other sounds telegraphically, as herein described, by causing electrical undulations similar in form to the vibrations of the air accompanying the said vocal or other sounds.

(Indorsement.)

These papers were received by me from Prof. Alex. G. Bell, in the winter of 1875-76, shortly before I left for England. I can fix the exact date by reference to my books and papers, but have not these at hand now.

Toronto, 12th November, 1878.

GEO. BROWN.

In regard to this defence of fraudulent interpolation in Bell's specification, it is to be observed, as is stated by this Court in its opinion, "that during the whole course of the protracted litigation upon the Bell patent no argument was ever presented, based on this discrepancy, until the brief of Mr. Hill was filed in this Court on the 18th of January, 1887, six days before the argument in these appeals was begun." "Certainly there is nothing in the pleadings in any of the cases to direct attention to the materiality of this fact." The facts in regard to this alteration are quite particularly stated by this Court in its opinion.

Gray's caveat was sworn to at Washington, February 14, 1876, and filed on the same day.

When the electrical examiner took up Bell's application for examination in February, he found that the caveat of Gray had been filed on the same day. The statute about interferences between applications and caveats (R. S. 4902) provides:



## Statement of the case.

“Such caveat shall be filed in the confidential archives of the office, and preserved in secrecy, and shall be operative for the term of one year from the filing thereof; and if application is made within the year by any other person for a patent with which such caveat will in any manner interfere, the commissioner shall deposit the description, specification, drawings and model of such application in like manner in the confidential archives of the office, and give notice thereof, by mail, to the person by whom the caveat was filed.”

After receiving the notice, the caveator may, “if he desires to avail himself of his caveat,” file an application within three months.

The examiner gave to Mr. Bell’s solicitors the following notice:

“February 19, 1876.

“*Telegraphy.*—In this case it is found that the first, fourth, and fifth clauses of claim relate to matters described in a pending caveat.

“The caveator has been notified to complete, and this application is suspended for ninety days, as required by law.

“Z. F. WILBUR,

“*Examiner.*”

At the same time he sent to Gray the following notice:

“February 19, 1876.

“*Sir:*—You are hereby notified that application has been made to this office for letters patents for telephonic telegraph, etc., with which the inventions described in your caveat, filed on the 14th day of February, 1876, apparently interferes, and that said application has been deposited in the confidential archives of the office, under provision of Section 4902 of the Revised Statutes of the United States, which section reads as follows:” (Then follows copy of R. S. 4902).

“If you would avail yourself of your caveat, it will be necessary for you to file a complete application within three

## Statement of the case.

months from this date, three days additional, however, being allowed for the transmission of this notice to your place of residence.

“ Very respectfully,

“ R. H. DUELL,

“ *Commissioner.*”

“ Elisha Gray, care W. D. Baldwin, present.”

Also the following notice :

“ Examiner’s Room, No. 118, U. S. Patent Office,

“ WASHINGTON, D. C., February 19, 1876.

“ E. Gray, care W. D. Baldwin :

“ In relation to the following notice in relation to your caveat, it may be well to add that the matters in the application referred to seem to conflict with your caveat in these particulars, viz. :

“ 1st. The receiver set into vibration by undulatory currents.

“ 2d. The method of producing the undulations by varying the resistance of the circuit.

“ 3d. The method of transmitting vocal sounds telegraphically by causing these undulatory currents, etc.

“ Z. F. WILBUR,

“ *Examiner.*”

Mr. Bell’s solicitors, believing that their application was filed early in the day, doubted whether the caveat was filed as early as the application, and thereupon addressed to the Commissioner of Patents a communication on the subject.

On this the examiner then added the following indorsement :

“ Examiner’s Room, No. 118,

“ February 25, 1876.

“ The cash blotter in the chief clerk’s room shows conclusively that the application was filed some time earlier on the 14th than the caveat.

## Statement of the case.

"The application was received also in 118 by noon of the 14th; the caveat not until the 15th.

"Z. F. WILBUR,

"*Examiner.*"

Upon this, he sent to Mr. Bell's solicitors the following communication:

"Examiner's Room, No. 118, U. S. Patent Office,

"WASHINGTON, D. C., February 25, 1876.

"A. G. Bell, care of Pollock & Bailey, present:

"February 14, 1876.

"*Telegraphy.*—The suspension of this application, having been declared under a misapprehension of applicant's rights, is withdrawn.

"Z. F. WILBUR,

"*Examiner.*"

The memorandum or fee-ticket says that the money was paid February 14, 1876, and adds, "*Paper will be filed to-day.*"

Mr. Gray wrote to Mr. Bell February 21, 1877, that he was aware that the caveat was filed some hours later than the application.

The defendants also set up that James W. McDonough, of Chicago, was a first inventor of the speaking telephone.

He was called as a witness.

His original apparatus was long before destroyed, and even his model was lost in the Patent Office fire. A few experimental pieces remain, but essentially the whole proof as to what his instrument was rests on the description in his application of April 10, 1876, and the memories in 1881 of himself and of the members of his family. He never tried it except in his own room in his house. It was never seen except there and by the members of his household.

He was a large furniture manufacturer in Chicago, and had taken several patents for furniture, casters, etc.

McDonough's application is explicit in its description of the operation of the apparatus by which he wished to trans-

## Statement of the case.

mit speech. It is given in full in the evidence in the Molecular and Overland cases, and contains the following:

“The object of my invention is to provide a means for transmitting articulate sounds from one place to another through the medium of electricity; and it consists in the combination with an electrical battery circuit wires, armature, magnet and circuit-breaker, of a transmitting and a receiving membrane or sounding apparatus, so constructed as to vibrate in accord with the vibrations of articulate sound, and so arranged relative to the magnet and circuit-breaker that the vibrations of the transmitting membrane or apparatus, produced by articulate sounds, are transmitted by the electrical current to the receiving membrane or apparatus, and so as to cause a like vibration of the receiving membrane or apparatus, and\* it to produce the articulate sounds transmitted from and by the transmitting membrane or apparatus. My invention also consists in the novel construction of the circuit-breaker, as is hereafter more fully described.” “D’ is the circuit-breaker which consists of an arch-shaped piece of metal loosely secured at its centre upon the bolt D, and is bent upwards at each end, and from the membrane A, as shown in Fig. 3, so as to form depending V-shaped points adapted to rest upon the respective plates C, C’. The circuit-breaker D’ is so fitted upon the bolt D as to admit of a free and easy ascending and descending movement, the limit of its ascending movement being determined by its contact with the nut E on the bolt, and the descending movement being limited by its contact with plates C, C.

“The operation of my said telelogue is as follows: The transmitting membrane A, being sensitive to the vibrations of articulate sounds produced thereon, is caused to vibrate in sympathy therewith, thereby imparting an upward movement of the circuit-breaker at each vibration, and disconnecting it from the plate C C and alternately breaking and closing the circuit, when the intermittent current alternately

\* A word, probably “cause,” is wanting in the original.—Ed.

J. W. McDONOUGH.

TELELOGE.

Filed April 10, 1876.

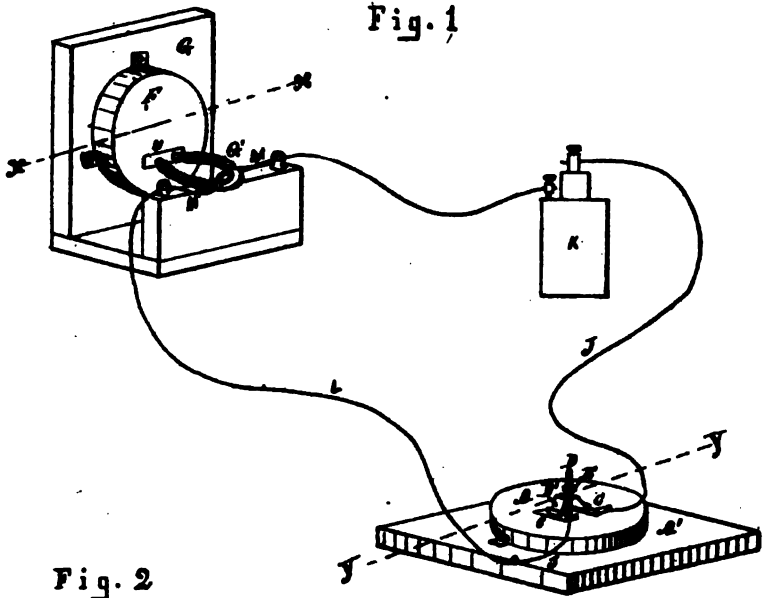

Fig. 2

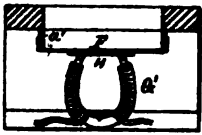
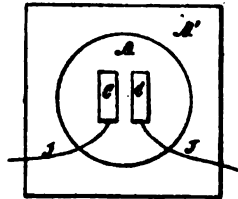

Fig. 3



Fig. 4



WITNESSES:  
Julius Wilcke  
R. B. Heston.

INVENTOR:  
James W. McDonough  
By Girdley & Sherburne  
Attys



## Statement of the case.

magnetizes and demagnetizes the magnet G', attracting the armature H, and causes it and the membrane F to vibrate simultaneously with the vibrations of the transmitting membrane A, and in accord therewith, and so that the said membrane F reproduces the articulate sounds transmitted from and by the membrane A.

"I do not limit myself to the construction and arrangement of the circuit-breaker D', as shown and described, as other means may be employed; as, for example, one of the plates C may be attached to the membrane; and the other made either in the form of a plate or needle, and attached direct to the connecting wire, and adjusted to rest upon the plate so as to break the connection by the vibrations of the membrane, which will accomplish the same result. It will be observed that each end of the circuit-breaker D' is bent upward from the membrane; the object being to prevent local attraction and render its action more sensitive to the lighter vibrations of the membrane. The articulate sounds may be taken direct from the magnet or through any substance or material sufficiently sensitive to the vibration of sounds to reproduce them by contact with the magnet.

"Having thus described my invention, what I claim as new, and desire to secure by letters patent is:

"1. The combination with the battery, circuit wires, magnet, armature and circuit-breaker of the transmitting membrane A, and receiving membrane F, substantially as, and for the purpose, specified.

"2. The combination with the plates C, C, of the circuit-breaker D', whereby the circuit is alternately opened and closed by the vibrations of the membrane A, substantially as specified.

"3. The combination of the bolt D, and adjusting nut E, of the circuit-breaker D', substantially as and for the purpose specified."

The following are the specifications of the two patents of Cromwell Fleetwood Varley, of London, England, granted,

## Statement of the case.

one June 2, 1868, in the United States, and the other October 8, 1870, in England, for "Improvements in Electric Telegraphs," which are claimed to have anticipated the invention of Bell.

CROMWELL FLEETWOOD VARLEY, OF LONDON,  
ENGLAND.

## IMPROVEMENTS IN TELEGRAPHING.

Specification forming part of Letters Patent No. **78,495**, dated  
June 2, 1868.

*To all whom it may concern :*

Be it known that I, CROMWELL FLEETWOOD VARLEY, of London, England, temporarily residing in New York, County of New York, and State of New York, have invented certain new and useful Improvements in Electric Telegraphs: and I hereby declare the following to be a full, clear and exact description of the same.

The objects of my invention are to cut off the disturbance arising from earth-currents, to obtain a high speed of signaling through long circuits, and, should the conductor become partially exposed, to preserve it from being eaten away by electrolytic action.

No means, prior to my invention, had been devised for effecting the first and third of these results. I have devised several other methods less perfect than those hereinafter described, but all embodying the general principle of my invention.

The invention consists of the arrangement of well-known apparatus, whose action, being of an electric and magnetic character cannot be explained by drawings or models; but the accompanying diagrams and specification will enable those skilled in the art to understand the invention.

The telegraphic signals in this invention are made to



C. F. VARLEY.

Telegraph.

No. 78,495.

Patented June 2, 1868.

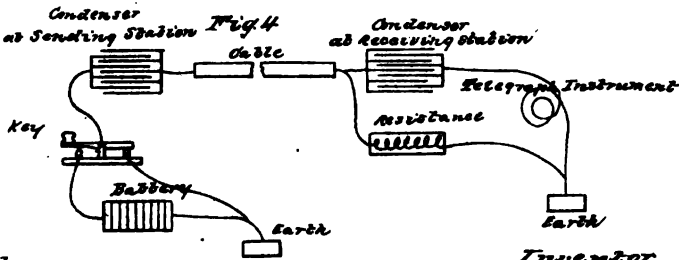
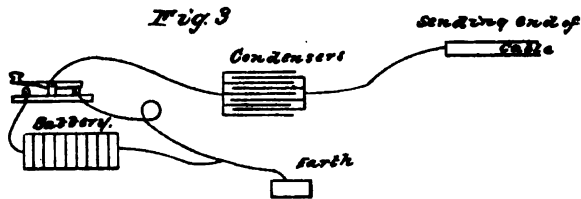
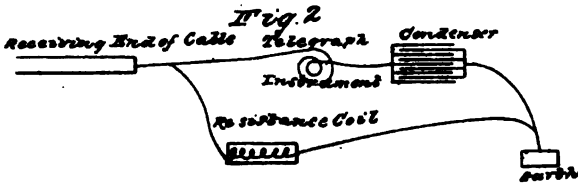
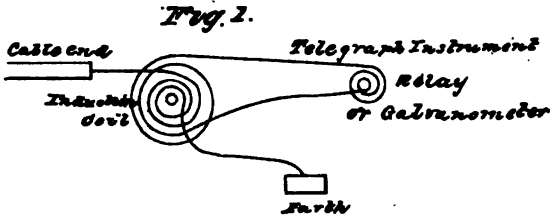

Witnesses  
M. O'Byrne  
C. Hays Jr.

Inventor  
Cornell Hudson Varley  
by his attorney



## Statement of the case.

depend upon the rate of change of electrical potential, and not upon the strength of the current or charge in the cable.

As the earth currents—*i. e.*, the electric variations in the earth itself—change their strength slowly, the indications produced by them with this invention, in which the strength of the signals depends upon the rate of change of strength, are so feeble as to escape notice, and the embarrassment arising from this cause on long lines is, to all practical purposes, avoided.

There are two modes by which this is effected, and a higher rate of signaling through long cables obtained. The first plan is by means of an induction-coil. The cable at the receiving end of the circuit is connected to the primary wire of an induction coil, and through it to the earth. The secondary wire is connected to the telegraph instrument. This arrangement is represented by Diagram No. 1.

Explanation of its action: On a current passing through the primary wire of the induction-coil, the iron core becomes magnetized, and this magnetization produces a current in the secondary wire, which acts upon the telegraphic instrument.

When the current in the primary wire has reached its maximum force, and is flowing steadily through, the iron core is magnetized to a certain fixed amount, and then the current in the secondary wire ceases. If, now, any change in the strength of the current through the primary wire occurs, the amount of magnetization of the iron core will vary, and a corresponding current in the secondary wire will result.

The earth-currents seldom pass from zero to their maximum and back again to zero (prior to changing sign) in less than five or six minutes, while the telegraphic signals are generally produced in a small fraction of a second.

With the former, although the currents are often very strong, the rate of change of strength is extended over several minutes, and consequently the current in the secondary

## Statement of the case.

wire is very feeble, as its strength is mainly dependent upon the rate of variation of the magnetism of the iron core.

The signaling currents or impulses are much more rapid or sudden, and consequently the variation of the magnetism of the iron core is much more sudden, and the currents generated thereby in the secondary wire are comparatively powerful and distinct.

Thus, then, suppose the earth to send a current through the line—say a positive ( ) current from the sending to the receiving station—and to slowly magnetize the iron core, and, for ease of explanation, suppose this earth-current to remain for a time steady and uniform in strength; let, now, the sending station make a signal. In doing so his battery adds its strength to or opposes the earth-current, according as the signal sent is + or — (positive or negative).

This sharp and comparatively sudden addition to or subtraction from the earth-current produces a rapid augmentation or diminution of the magnetism in the iron core, and thus produces a distinct signal in the secondary wire.

For still further explanation, suppose the earth-current to be +, and to have a strength of 100 plus or positive, and the signal current to have a strength of 10, if a positive signal be sent, the current will rapidly rise at the receiving end in the proportion of 100 to 110. This rapid increment of magnetism will produce a positive signal in the secondary wire, corresponding to the increment 10. But if a negative signal be sent, then the battery will be opposed to the earth-current, and the current will rapidly fall at the receiving end in the proportion of 100 to 90, the magnetism in the iron coil will experience a rapid decrease, and a negative signal will be produced in the secondary wire corresponding to the decrement (or negative increment) 10, although the current through the line or cable still remains strongly positive.

As the strength of those secondary signals is almost entirely dependent upon the rate of increment and decrement of the current through the primary wire, and as the slowest

## Statement of the case.

line yet constructed need not require so much as half a second to produce a clear signal, while the earth takes five minutes or six hundred half seconds, the current arising in the secondary wire from the earth-current (which, although assumed to be ten times stronger, is six hundred times slower) is  $\frac{10}{600} - \frac{1}{60}$  part only of the strength of the signal, and the effects of the earth-current are consequently practically cut off.

When signaling through a very long cable, a rapid succession of signals charges the cable and produces an electric wave which is a long while subsiding, and acts at the receiving end in a somewhat analogous manner to the earth-current just described. This prevents signals from being transmitted in rapid succession by the ordinary means.

The above apparatus, which may be popularly described as disentangling the short high crested waves from the large long swells, enables clear distinct signals to be produced rapidly one after the other.

The strength of the signals through the cable or telegraph circuit is produced by the rate of the increments and decrements of current, and not by the current itself; and as an imperfect illustration, if the great earth-current through the cable be compared with an Atlantic swell whose height is five fathoms, but spreading horizontally over five or six hundred fathoms, and whose sides will have an angle of say one hundred and seventy-eight degrees, and if the signals be compared with the ripples produced by the wind upon the back of the swell, and whose angles are each, say, sixty degrees, then an apparatus that will indicate these angles would scarcely notice the angle of one hundred and seventy-eight degrees, which is nearly a straight line (or one hundred and eighty degrees), while the small waves, with an angle each of sixty degrees, would be distinct, and such apparatus would disentangle the small signals from the big swell, paying almost no attention to the latter. Electric waves are entirely different from water waves; but the illustration may serve to explain the action of the former.

## Statement of the case.

The second plan of effecting the above is more expensive in construction, but more perfect in action. A large condenser is inserted in the circuit at one or both ends, according to the circumstances of the case. At the receiving end of the line I prefer the following arrangement (Diagram No. 2), which gives a rapid rate of signaling.

The cable is connected to the one armature of the condenser through the telegraph receiving instrument, and the other armature is connected with the earth. The cable is also connected to the earth by means of a resistance coil, which is best when made of a long length of insulated copper wire, wound round an iron core.

On a current running through the line or cable it finds at the distant end two routes or channels, viz., the resistance coil and the condenser. The condenser route at the first moment offers no other sensible resistance than that of the receiving instrument, while the other, owing to the magnetic inertia of the iron core, offers at the first moment a considerable resistance. The condenser is rapidly charged, and as soon as it is charged to the full force or potential of the current in the cable, all the rest of the electric current goes through the resistance coil to earth, and no more current is shown upon the receiving instrument. If, now, the potential in the cable be reduced or increased a little, the change in the condenser is reduced or increased in proportion, and a negative or positive signal can be distinctly produced at pleasure, although the electric current or charge in the line or cable has not changed sign, but only varied in strength. The resistance coil, between the cable and the earth, may be dispensed with; but then the little signal wave does not reach its maximum so rapidly, and consequently the signals are not so rapid (*vide* Diagram 6).

Observe, the receiving instrument may be placed between the second armature of the condenser and the earth or ground, instead of between the cable and the first armature. A condenser may also be employed at the sending end of the

## Statement of the case.

line or cable, either with or without a condenser at the receiving end of the line or cable. When a condenser is inserted at the sending end only of the line, the resulting signal is very similar to that produced by a condenser at the receiving end only; but the disturbing action of the earth-current, however, is more felt when the condenser is only placed at the sending end, because the earth-current has to charge the cable in addition to the condenser, all of which charging current has to pass through the receiving instrument. When the condenser is used at the sending end of the cable or line (Diagram 3), the cable is connected to the one armature of the condenser, and the telegraph key to the other armature of the condenser. An ordinary double or reversing key is generally used, so that when the one is depressed a positive charge is communicated to the condenser armature attached to it, and when the other is depressed a negative charge is communicated to it.

If the key had been connected to the line or cable in the usual manner, a constant or permanent current would have been produced through the cable so long as the contact was maintained, and this current would only begin to die away when the contact with the battery was broken or reversed. But when the condenser is interposed in the circuit, as described, so soon as the current from the battery has charged the condenser, the current from the condenser is arrested and variations in the length of the battery-contact beyond a fixed amount will produce no change in the amount of current thrown into or induced in the cable. In this way great uniformity and regularity of signals are obtained.

At the sending end of the line it is sometimes advisable to use a smaller condenser than at the receiving end, and higher battery power, because the more sharp and sudden the impulse is given the quicker will the signal appear at the distant end.

If the dimensions of the condenser be reduced, say halved, and the battery power be augmented in the inversed ratio,

## Statement of the case.

then the shock or impulse will be the same in amount, but more sudden, producing a rather more rapid signal at the distant end; but the disturbing action of the earth-currents is reduced as the dimensions of the condenser are reduced at the receiving end.

In some cases, such, for example, as where the Morse instrument is used, it is advisable to connect together the two armatures by means of a very large resistance, as shown in Diagram 6, so that after the condenser is charged the current through the cable shall not entirely cease. Thus the sharp sudden impulse of the condenser charges the cable and would produce a dot, but not a line or dash. The weak current through the large resistance, however, maintains the current in the cable, and a dash is produced, the Morse armature being held down by this weak current so long as the key is held down.

On the key being elevated the charged condenser is connected to the ground if the condenser be at the sending end; and in discharging itself the condenser produces a short, sharp current in the cable in the opposite direction, which rapidly terminates the signal at the distant end of the cable.

All cables are liable to have their insulation impaired. When this is the case, and the proper conductor is exposed to the sea water, the copper is decomposed whenever a positive current is permitted to flow from the copper into the water, forming a chloride of copper, which is soluble and effuses itself and floats away.

If the cable be kept always negative to the water, the action of the positive current flowing into the wire from the water is to preserve the wire from decomposition.

To effect this I place a condenser at each end of the cable (Diagram 7), and also connect to the cable, through a large resistance (or long coil of fine wire), a battery whose positive pole is connected to the earth at a negative pole to the resistance coil. This keeps the cable always negative to the



## Statement of the case.

water, and yet the signals through it and the condensers are either positive or negative, at pleasure. Suppose the signal impulse to be a positive one, it weakens the negative character of the charge in the cable, and also in the distant condenser, and immediately a corresponding positive signal is produced in the distant instrument.

If the signal impulse be negative it increases the negative charge in the cable and also in the distant condenser, and therefore produces a negative signal in the distant instrument, and thus, although positive and negative impulses are produced at the distant end, the cable has been only less or more negative, but never positive to the sea, and therefore the conductor has been constantly under the preservative action of the negative current.

Thus, then, the action of the condensers and battery has not been only to cut off the effect of the earth-currents and to expedite the transmission of signals, but also to preserve the conductor of the cable from destruction if exposed to the sea water.

In Diagram 7 the place of the switches or commutators is shown. These have been omitted in the other diagrams to simplify them. These commutators are of the ordinary well known form, common to most systems of submarine telegraphing, and are not a part of this invention.

Having now described my invention and the manner in which the same is or may be carried into effect, what I claim and desire to secure by letters patent is:

1. In so arranging telegraphic apparatus as to work by the variation of the increment and decrement of electric potential, and not by the direct action of the electric current itself, as and for the purposes set forth.

2. The use of an induction-coil at the receiving end of the cable, one of its wires being connected between the cable and the ground, and the other or secondary wire connected with the receiving instrument, as and for the purposes set forth.

3. The use of a condenser or condensers between the

## Statement of the case.

receiving end of the cable and the earth, with or without resistance coils between the cable and the earth, as and for the purposes set forth.

4. The use of a condenser at the sending end of the cable, with or without resistance coils, connecting its two armatures, as and for the purposes set forth.

5. The use of a condenser at each end of the cable, the cable being connected with the ground through a resistance coil and a battery, so as to keep the cable always negatively electrified, as and for the purposes set forth.

In testimony whereof I have signed my name to this specification before two subscribing witnesses.

C. F. VARLEY.

A. D. 1870, 8TH APRIL, No. 1044.

## ELECTRIC TELEGRAPHS.

Letters Patent to Cromwell Fleetwood Varley, of Beckenham, in the County of Kent, for the Invention of "Improvements in Electric Telegraphs;" sealed the 7th June, 1870, and dated the 8th April, 1870.

Provisional specification left by the said Cromwell Fleetwood Varley at the office of the Commissioner of Patents with his petition, 8th April, 1870.

I, CROMWELL FLEETWOOD VARLEY, of Beckenham, in the County of Kent, do hereby declare the nature of the said Invention for "Improvements in Electric Telegraphs," to be as follows:

This Invention has for its object the increase of the transmitting power of telegraph circuits, by enabling more than one operator to signal independent messages at the same time upon one and the same wire to and from independent stations.

## Statement of the case.

In working land lines it is usual to produce the signals by means of the passage of a current of electricity producing magnetic action, as in the Morse or Hughes instruments, or chemical action, as in the Baines machines.

By my invention I superpose upon the currents used for working the ordinary telegraphs, rapid undulations or waves which do not practically alter the mechanical or chemical power of the ordinary signal currents, and by new apparatus, hereinafter described, these undulations are made to produce distinct and independent audible or other signals, so long as these undulations are produced, whether ordinary signal currents be flowing or not.

As a rough mechanical illustration of the way in which I propose to pass two sets of elastic signals simultaneously, and in either direction through the same line-wire without interference, I will suppose a rope stretched over two distant pulleys by means of weights at each end; if the near weight be raised the distant one falls. In this way signals are transmitted by the connecting rope, which may be called current signals; if now two small pulleys, capable of rising and falling, rest upon the rope between but near to the supports, they will simply rotate when the rope is shifted backwards and forwards; if now an operator at one end strikes the rope, vibrations or waves will be produced which will cause the other small pulley to dance or make vibration signals. Consequently the operator who shifts, and the operator who strikes the rope, can each produce independent signals on one and the same rope. Suppose the rope to travel over several fixed pulleys, the operation of shifting the rope will produce distinct current signals from end to end of the line as before, but between each fixed pulley vibrations can be produced, and so a number of intermediate stations can communicate independently of each other and independently of the current signals through the line.

With this mechanical simile the following will be more easily understood.

## Statement of the case.

The way in which I carry my electric invention into operation is as follows :

An electro-magnet offers at the first moment great opposition to the passage of a current of electricity, and therefore it may be considered as partially opaque to the transmission of very rapid alterations or electric waves. I attach to the line at desirable parts condensers. In the first instance I will assume only two condensers, one at each end, attached near each end of an ordinary telegraph line. The first or communicating station produces in its condenser rapid charges and discharges; these add to and take from the line a number of small electric impulses without affecting the mean magnetizing power of the currents through the line. These impulses charge and discharge the second condenser at the other end.

These undulations in the second condenser can be utilized in the following manner :

1. If the condenser be made of \* paper and metal foil the rapid charges and discharges produce a musical sound.

2. If these rapid alterations be made to pass round a helix containing an iron rod a musical sound is produced.

3. If these currents pass round a helix containing a magnetized harmonium tongue, the currents make it vibrate audibly if the currents be properly timed, and the effect is increased if a feeble current of air be passing the tongue. By adding tubes of proper length and sounding boards and other appliances for communicating vibrations the power of the signal is increased.

4. By placing the magnetized tongue of a musical comb between the poles of an electro-magnet with only a small iron core, or inside a coil, it is made to vibrate whenever these undulations are passing.

5. Another method of producing sound from the undulations consists of stretching a music wire through hollow helices; the currents magnetize and demagnetize the tone,

\* This blank occurs in the English specification.

## Statement of the case.

this wire being also placed between the poles of permanent magnets. Harmonious currents cause this wire to vibrate. In some cases it may be useful to employ inharmonious currents to stop or silence the vibrations. The two latter methods will only speak when vibrations of harmony with the tongue are made to pass, and consequently in some cases two or more distinct sets of vibrations can be made to act on two or more sets of apparatus differently tuned, and to permit of several distinct communications to be transmitted simultaneously upon the same section of a single line-wire. By introducing between the receiving condenser and a Morse or other ordinary receiving instrument a current reverser keeping time with the vibrations, these alternating currents are made to flow through the receiving instrument in one direction, and are then competent to work the Morse or other ordinary receiving instrument.

6. When it is desirable to subdivide the vibrating sections of a line an electro-magnet, or, what is better, two electro-magnets are inserted in the circuit, and a condenser may with advantage be placed between the circuit and the earth, connecting the condenser with the circuit between the two electro-magnets. In this way, without interfering materially with the ordinary signals through the line, the vibrating sections are separated from each other, by withdrawing the iron cores from the electro-magnets, or, short circuiting the electro-magnets, the vibrations are passed through to the next station.

7. Another method consists of inserting a reflecting galvanometer between the condenser and the earth (or between the line and the condenser); the vibratory or secondary signals can be read off by observing its vibrations.

8. Vibrations are rendered sensible by placing a movable iron bar between the poles of an electro-magnet or inside a helix, and one or both of its ends between the poles of permanent magnets; the latter are covered with brass or any non-magnetic matter; the vibration currents cause it to vi-

## Statement of the case.

brate between the poles of the electro or permanent magnets, and so produce distinctly audible sounds.

9. There are other methods of utilizing these superposed vibrations, such as connecting to the condenser an electrometer like that of Milner or Pettier. An intermediate Morse or other such line instrument would cut off the vibration signals or reduce them much; this opposition of the intermediate electro-magnet may be cut off by connecting the terminals of a condenser to the circuit on each side of the magnet.

There are several methods of producing these vibrations in the wire:

1. If a tuning fork be placed between the poles of an electro-magnet with a spring contact so arranged that when at rest the battery current flows through the electro-magnet, the latter will attract the tuning fork and break the circuit; the magnetism then ceases and the tuning fork springs back and renews the circuit; in this way it keeps vibrating so long as the battery is in action. A secondary wire around this magnet produces currents in opposite directions, and by placing this secondary wire in circuit with the line-wire the necessary vibrations are produced.

2. The secondary wire may be connected between the earth and the condenser attached to the line-wire; this method does not add to the resistance of the main circuit, and is therefore preferable.

3. A tongue similar to those used in harmoniums is made to vibrate by air between contact points, and so connect the condenser alternately with the battery and the ground, and so produce the alternations, or it may be made to connect the condenser alternately to the + or — pole of a battery whose opposite poles are connected to the earth.

4. A magneto machine rapidly rotating will do the above duty equally well if its speed of rotation be controlled by a good governor. The tuning fork and vibrating tongue arrangement can be set to and can keep up any desirable rate of

## Statement of the case.

vibrations. The ordinary telegraph keys and switches are used for connecting the various parts of the apparatus together. In constructing the dry paper condensers it is best to dip the paper in varnish and attach metal leaf (such as gold, silver, or copper) to the paper, and lay these metal-coated papers between metal foil.

The double speaking apparatus of Dr. Gintl, or of Firschen, can be used on lines working with the above-described vibrations. When these are used I prefer inserting a hollow helix between the double speaker and the line, and by inserting iron rods in this helix the difficulty arising from the inductive capacity of the line is almost wholly removed. This is a new improvement, and will render these apparatuses actually useful instruments.

Specification in pursuance of the conditions of the Letters Patent, filed by the said Cromwell Fleetwood Varley in the Great Seal Patent Office, on the 8th October, 1870.

*To all whom these presents shall come, I, CROMWELL FLEETWOOD VARLEY, of Beckenham, in the County of Kent, send greeting:*

Whereas, Her most Excellent Majesty Queen Victoria, by Her letters patent, bearing date the eighth day of April, in the year of our Lord one thousand eight hundred and seventy, in the thirty-third year of Her reign, did, for Herself, Her heirs and successors, give and grant unto me, the said Cromwell Fleetwood Varley, Her special license that I, the said Cromwell Fleetwood Varley, my executors, administrators, and assigns, or such others as I, the said Cromwell Fleetwood Varley, my executors, administrators, and assigns, should at any time agree with, and no others, from time to time and at all times thereafter during the term therein expressed, should and lawfully might make, use, exercise, and vend, within the United Kingdom of Great Britain and Ireland, the Channel Islands, and Isle of Man, an Invention for "Improvements in Electric Telegraphs," upon the condition

## Statement of the case.

(amongst others) that I, the said Cromwell Fleetwood Varley, my executors or administrators, by an instrument in writing under my, or their, or one of their hands and seals, should particularly describe and ascertain the nature of the said invention, and in what manner the same was to be performed, and cause the same to be filed in the Great Seal Patent Office within six calendar months next and immediately after the date of the said letters patent.

Now know ye, that I, the said Cromwell Fleetwood Varley, do hereby declare the nature of the said Invention, and in what manner the same is to be performed, to be particularly described and ascertained in and by the following statement thereof, that is to say :

This Invention has for its object the increase of the transmitting power of telegraph circuits, by enabling more than one operator to signal independent messages at the same time, upon one and the same wire, to and from independent stations.

In working land lines it is usual to produce the signals by means of the passage of a current of electricity producing magnetic action, as in the Morse or Hughes instruments, or chemical action, as in the Baines machines.

By my Invention I superpose upon the currents used for working the ordinary telegraphs, rapid undulations or waves which do not practically alter the mechanical or chemical power of the ordinary signal currents, and by new apparatus hereinafter described, these undulations are made to produce distinct and independent audible or other signals so long as these undulations are produced, whether ordinary signal currents be flowing or not.

As a rough mechanical illustration of the way in which I propose to pass two sets of electric signals simultaneously, and in either direction through the same line-wire without interference, I will suppose a rope stretched over two distant pulleys by means of weights at each end. With such an apparatus, if the near weight be raised the distant one falls, and



## Statement of the case.

in this way signals may be transmitted by the connecting rope, which may be called current signals. If now two small pulleys capable of rising and falling rest upon the rope, between but near to the supports, they will simply rotate when the rope is shifted backwards and forwards; but if now an operator at one end strike the rope, vibrations or waves will be produced, and will cause the small pulley at the other end to dance, and so vibration signals may be given. Consequently the operator who shifts, and the operator who strikes the rope, can each produce independent signals on one and the same communicating cord. Suppose the rope to travel over several fixed pulleys, the operation of shifting the rope will produce distinct current signals from end to end of the line as before, but between each fixed pulley and the next to it vibrations can be produced, and so a number of intermediate stations can communicate independently of each other and independently of the current signals through the line.

With this mechanical simile the following will be more easily understood.

The way in which I carry my electric invention into operation is as follows:

Condensers are attached to the line at the places where the wave signals are to be communicated and received. In the first place, let us assume only two condensers, one at each end, attached near each end of an ordinary Morse telegraph circuit. The first or communicating station to make a signal produces in its condenser rapid charges and discharges by means described; further on these add to and take from the line a number of small electric impulses without affecting the mean magnetizing power of the ordinary Morse currents through the line. These impulses charge and discharge the second condenser at the other end, and this condenser is coupled with a receiving instrument which is sensitive to these undulations and renders them apparent by sound or otherwise.

Fig. 1 is a diagram of the instruments at one of the stations

## Statement of the case.

of such a line; *a* is the line-wire, I will suppose it to be an ordinary land line-wire, 50 miles long and suspended in the usual way; *b* is the Morse instrument; *c* the sending key for the Morse signals, *d* the battery in connection with this key, and *e* its earth connection; *f* is a condenser of about 8 microfarads, one armature of which I couple with the line-wire and the other with a key *g*, which, when not depressed, puts the condenser in communication with the wave signal receiving instrument *h*, which I call a "cymaphen;" this instrument is shown at Figs. 2, 3 and 4. The key *g* when depressed for sending a wave signal puts the condenser in connection with the apparatus by which such waves are generated; this apparatus consists of a battery *i*; ten-quart cells of Daniel's battery will be suitable.

One pole of the battery *i* is connected with the tuning fork *k*; this fork may conveniently be of such dimensions as to make 200 vibrations in a second. *l*<sup>1</sup>, *l*<sup>2</sup> are two platina pointed contact-making springs, capable of fine adjustment by means of screws. The spring *l*<sup>1</sup> when the fork is at rest is in metallic contact with it or with a metal arm attached to it, and the spring *l*<sup>2</sup> is removed just out of contact. The current from the battery *i* then passes in the coils of the electro-magnet *m*, the poles of which have between them the two horns of the tuning fork. The coils of this magnet may be about 3½ inches long and 1½ inches diameter, and of No. 16 (B. W. G.) silk-covered copper wire. When the current is flowing through the coils of the electro-magnet the horns of the fork *k* are drawn apart and the spring *l*<sup>1</sup> loses its contact; then as the attraction of the magnet ceases the horns of the fork spring back; this remakes the contact, and so a continual tremor is communicated to the tuning fork. In the same circuit with the electro-magnet there is at *n* a primary coil wound upon a bundle of iron wires as a core, and on the same core, but wound in the opposite direction, is a second primary coil which is in connection with the spring *l*<sup>2</sup>, so that currents pass alternately in the two

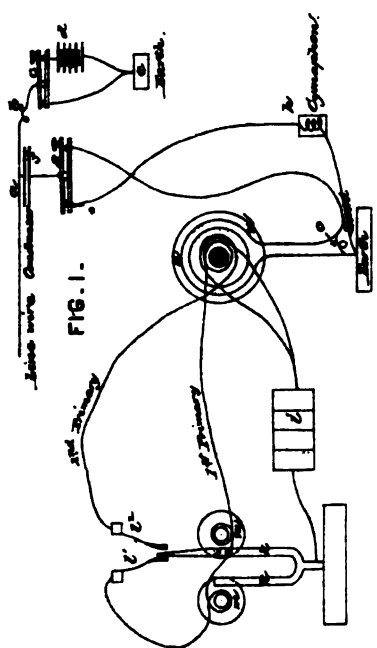

FIG. 6.

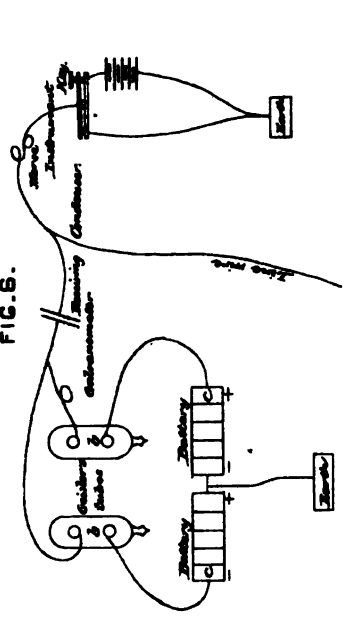

FIG. 5.

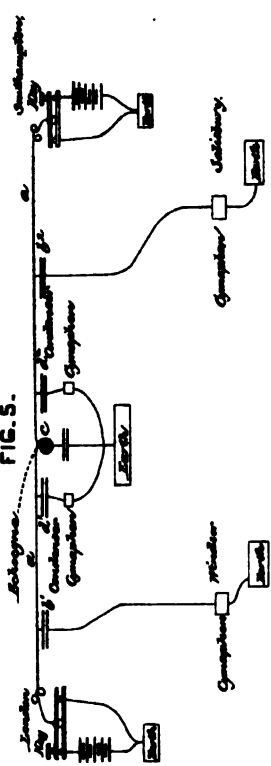

FIG. 7.

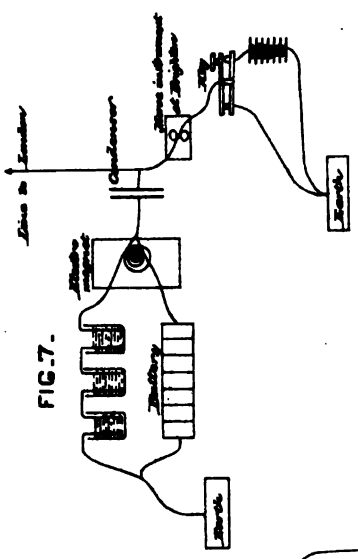

FIG. 8.

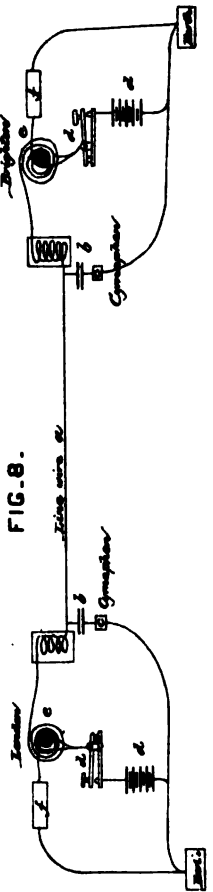



FIG. 3.



FIG. 4.

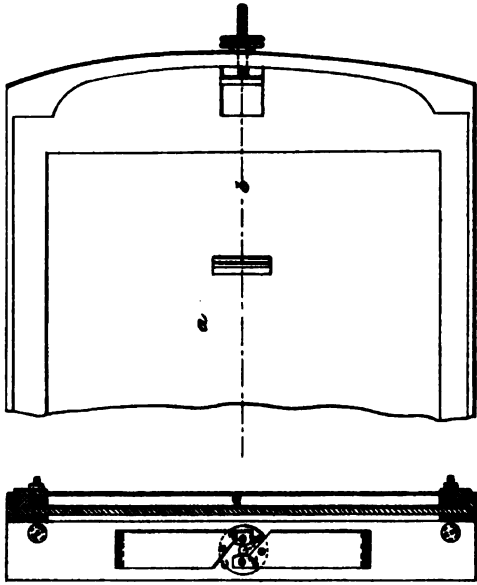
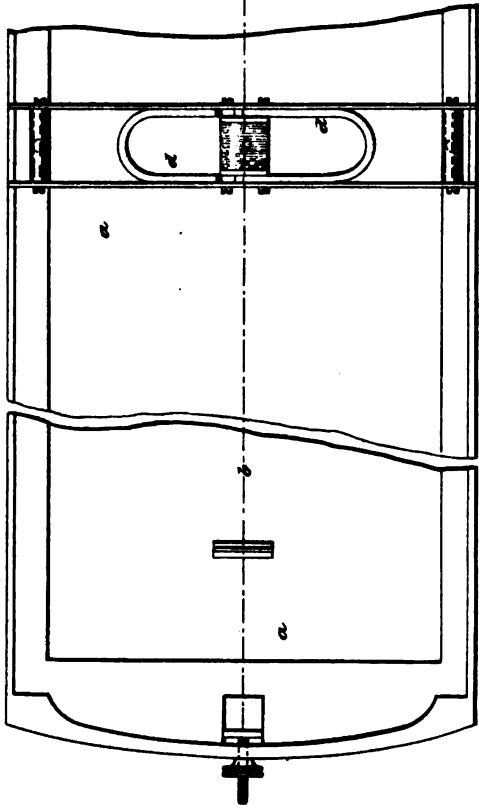
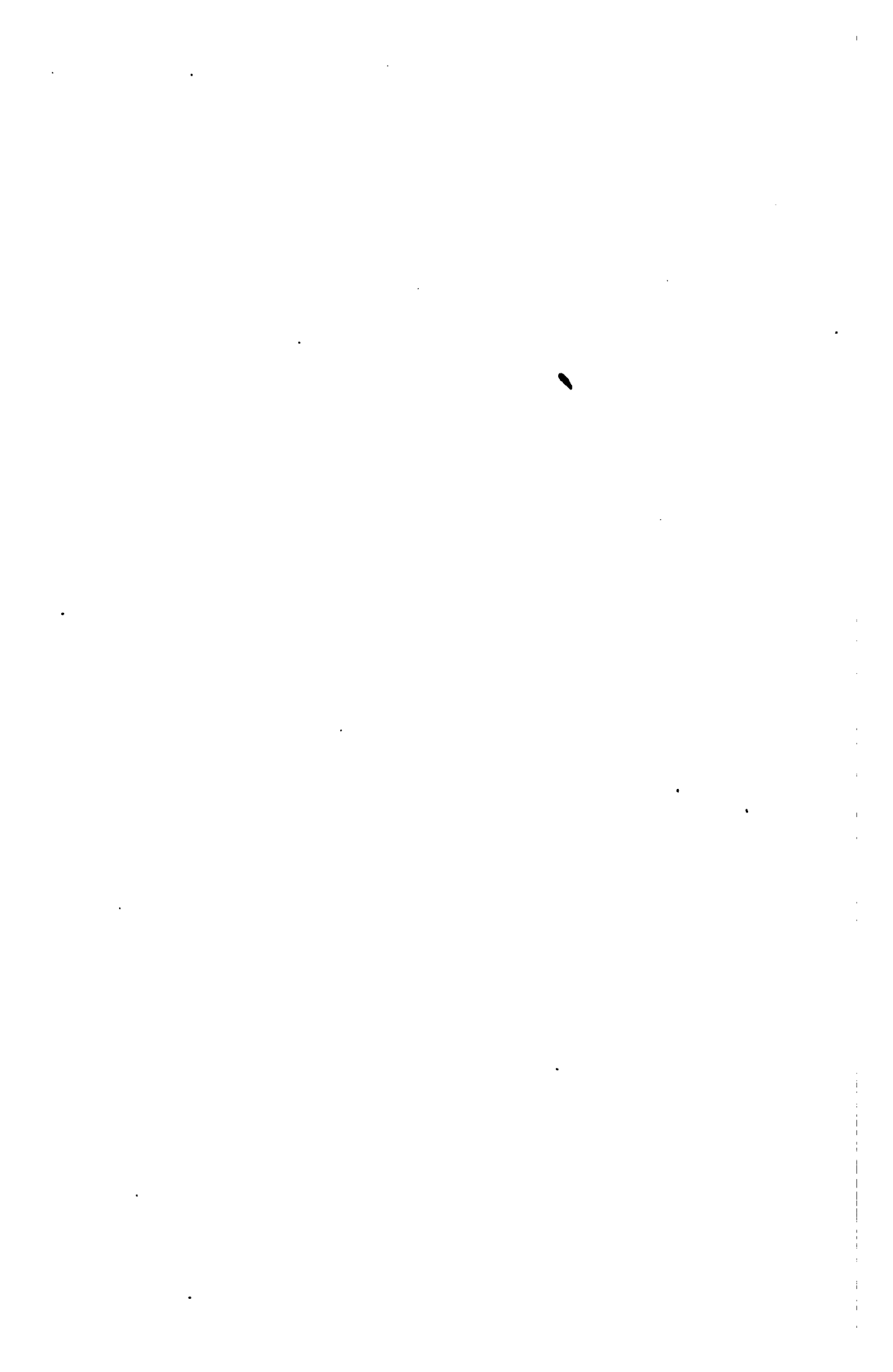

FIG. 2.





## Statement of the case.

primary coils, and at each alternation the polarity of the core is reversed. On the core there is also another or secondary coil, in which currents are induced by the changes of polarity of the iron core. One end of this secondary coil is connected with the earth, and the other, when a wave signal is to be sent, is by the key *g* put in connection with the condenser *f*, and produces in it rapid charges and discharges. The core may conveniently consist of a bundle of thin soft-iron wires, 1 inch in diameter and 32 inches long. On the centre of the bundle is wound for a length of eight, the first primary coil consisting of four layers of No. 16 silk-covered copper wire. Over this is wound the second primary coil consisting also of four layers, and outside this again is wound the secondary coil, consisting of eight layers of No. 24 silk-covered wire. The ends of the bundle composing the core are folded over so as to completely enclose the coils.

A small resistance coil *o*, or a condenser of about two micro-farads, is placed between the poles of the secondary coil to take off the violence of the shock, so that the operator shall not be inconvenienced. The wave signal receiving instrument *h* is shown in plan at Fig. 2, in longitudinal section at Fig. 3, and in transverse section at Fig. 4. It consists of an iron frame containing a sounding-board *a* over bridges, at the ends of which a hard drawn iron or steel wire *b* is stretched from one end to the other; this wire is about 4 feet and 6 inches long between the bridges; it is of No. 14 gauge, and is strained so as to sound the same note as the tuning fork of the sending instrument. This wire passes through a hollow helix *c*, three inches in length,  $\frac{1}{8}$  of an inch internal diameter and  $1\frac{1}{2}$  inches external diameter. The helix is wound with No. 35 B. W. G. copper wire insulated with silk. This coil is attached to the frame supporting the sounding-board, but does not touch the latter.

Two horse-shoe magnets *d* are placed one on each side of the wire. The currents magnetize the wire inside the helix, and so cause it to be attracted and repelled from one magnet

## Statement of the case.

to the other. When the wire is properly tuned so as to vibrate synchronously with the apparatus at the distant end, making the alternations in the current, the sound from very feeble currents is distinctly audible. A piece of felt or leather resting against the wire is sometimes used to "damp" the wire and stop its vibrations as soon as the impulses cease. A small piece of metal similar in dimensions to a gold five-franc piece may be made to rest by a spring lightly against the sounding-board somewhere near its centre. When the vibrations of the latter are powerful enough to make this piece of metal dance, the sound is increased in power four or five times by this little disc or sound reinforcer, or the sound may be augmented by clipping on to the wire near the helix a disc about the size of a penny piece of thin sheet metal; this causes the vibration of the wire to produce a greater disturbance in the air than it otherwise would, and a louder sound is perceived.

By attaching a stethoscope to the sounding-board for the reader to rest his ear against, very feeble sounds are rendered sufficiently audible; I prefer to use a Scott Allison's stethoscope.

The sounding-board may be replaced by a strained diaphragm or drumhead, on which one of the bridges over which the wire is strained is supported; this arrangement gives a better sound with very feble currents, but with moderate currents the sounding-board appears to have the advantage.

Two sets of wave signals may be transmitted and received simultaneously through the same wire, and independently of the current signals if a sufficient difference be made in the periods of the two sets of waves. Thus, if waves of 200 vibrations in the second, and waves of 850 or 900 vibrations in the second, be simultaneously transmitted and received by two separate cymaphens, the one adjusted to the slow, and the other to the rapid vibrations, they may be separately read, as the vibrations which affect the one are inoperative



## Statement of the case.

on the other. This arrangement is not applicable when working long distances, as the rapid waves would in a long distance be lost.

Fig. 5 is a diagram illustrating the arrangements I make when the wave signals are used to communicate between intermediate or branch stations, without interfering with the working by ordinary instruments of the main line;  $a$  is the line-wire, say between London and Southampton, and through it, it is desired that the intermediate station, Basingstoke, shall without interference with the through messages be able to communicate to and fro with the branch stations, Winsor and Salisbury. At these branch stations I provide wave signal apparatus such as already described in respect to Fig. 1, coupled with condensers  $b^1$ ,  $b^2$ , at the places where the branches run into the main line. At the intermediate station, Basingstoke, I divide the line-wire into two sections (as far as the wave signals are concerned) by introducing at  $c$  an instrument which is opaque to these waves, whilst it allows the ordinary long current signals to pass freely. This opaque instrument  $c$  I call "echocyme," and on either side of it I connect with the line wire a condenser  $d^1$ ,  $d^2$ , and wave signaling apparatus, as already described.

An electro-magnet offers at the first moment great opposition to the passage of a current of electricity, and may be considered as nearly opaque to the transmission of very rapid alternations of current or electric waves. The "echocyme" may consequently be a simple electro-magnet, or what is better is to wrap an induction-coil with two wires so as to form one continuous coil; this is put into the line circuit. The junction between these coils is connected to the one armature of the condenser, whose other armature is connected to the earth. The momentary action of a current on passing through one wire charges the condenser. The secondary action upon the other wire checks the current that the condenser would have sent on through the other wire on to the

## Statement of the case.

remainder of the main line circuit ; by varying the size of the condenser, according to the nature of the line and currents employed, a nearly absolute stopper of the vibration signals is produced. The coil which I have used for this purpose has the following dimensions: Iron bundle 1 inch in diameter, length of coil 8 inches, and wound with No. 26 insulated copper wire to a diameter of 2 inches. The condenser connected between the "echocyme" and the earth in the case which I have taken for illustration should be of about  $\frac{1}{16}$  of a micro-farad. At the termini Morse or other ordinary instruments may be used.

There are various ways in which the wave signal receiving apparatus may be constructed, although that which I have already described I prefer ; thus the condenser itself may be the receiving instrument.

If the condenser be made in the following manner, the rapid charges and discharges will produce a musical sound. Sheets of tinfoil (for example, one foot square) are separated by one or more sheets of thin dry paper ; the 1st, 3d, 5th, etc., sheets are joined together ; the 2d, 4th, 6th, etc., also joined together. The odd-numbered sheets are connected to a binding screw or terminal, and the even-numbered sheets to another terminal. Such a condenser, consisting of from 20 to 50 sheets will be found to be much agitated, and to produce a loud note with 500 alternations. of current per second if the potential be 50 to 100 volts.

In constructing the dry-paper condensers the following method seems to answer best: Very thin uniform paper is dipped in shellac varnish, coated on one side with gold leaf, and then dried. The non-gilt surfaces of 2 sheets of paper are put together so as to leave the gilt surfaces outside ; the tinfoil plates are placed outside of these and built up in the usual manner, connecting the 1st, 3d, 5th, 7th, etc., plates to one armature of the condenser, the 2d, 4th, 6th, 8th, etc., being joined to the other armature of the condenser. If the rapid alternations of current be made to pass round a helix

## Statement of the case.

containing an iron rod, the iron rod will issue a feeble but distinct sound. The rod used may be  $\frac{1}{8}$  of an inch in thickness, 18 inches in length, and covered to a diameter of 1 inch with No. 35 insulated copper wire. This arrangement requires strong currents. If the currents pass round a flat coil in which a magnetized harmonium tongue is placed, the currents will act upon it like the needle of a galvanometer and cause it to vibrate.

The sound is increased by causing a feeble current of air to pass the tongue. If a steel tongue, similar to one of those used in a musical box, be magnetized and placed inside a helix of fine wire, and its lip is placed between the poles of a powerful permanent magnet, the alternating currents will cause the tongue to vibrate and produce a musical sound so long as the alternations are operating. By coating a wire, strained, as is shown in Figs. 2 and 3, near the coil, with a short tube of gold or platinum, and letting a light spring formed of the same metals rest against the wire, a relay is produced, which, bringing into operation a local battery, can be used to increase the sound or to relay on the signals to another line.

A thick music wire, much thicker than those used in pianofortes, is found to give the best results for sound. A thin wire is thrown into greater oscillation than a thick one, and admits of being utilized for visible signals in the following way: A steel wire of about No. 40 gauge is stretched through the helix in front of a very narrow slit. A flame is passed behind the slit, but the light coming through is checked by the wire; the moment, however, the wire is put into vibration light passes, a lens is placed in front, and by it a magnified image of the luminous slit is projected upon a white screen so long as the wire vibrates. Vibrations are rendered sensible by placing a movable iron bar between the poles of an electro-magnet or inside a helix, and one or both of its ends between the poles of permanent magnets; the latter are covered with brass or any non-magnetic matter. The

## Statement of the case.

vibration currents cause it to vibrate between the poles of the electro or permanent magnets, and so produce distinctly audible sounds.

Another method of utilizing these alternations is by introducing between the receiving condenser and a Morse or other ordinary receiving instrument a current reverser keeping time with the vibrations; these alternating currents may be made to flow through the receiving instrument in one direction, and are then competent to work the Morse or other ordinary receiving instrument. Or a similar result may be obtained by the arrangement shown at Fig. 6, which consists in connecting the receiving condenser to two "Geisler's" vacuum tubes *a* and *b*; the latter are connected with voltaic batteries C, Z, consisting of a large number of elements. The one tube *a* is connected to the "positive pole" of a battery whose "negative pole" is connected to the earth. The second tube *b* is connected to the "negative pole" of a battery whose "positive pole" is to earth. These batteries must have nearly power enough to make a current pass through the tubes; for example, supposing 300 cells of a battery be able to leap across, the exhausted tube 290 should be used with each tube. When a positive current arrives it will help the battery whose positive pole is connected to the earth, and cause a current to pass through its tube *b*. The next instant the current is reversed; this causes a current to pass through the other tube *a*; in this way an electric valve is produced separating the positive from the negative currents, and producing a rapidly intermittent current in one direction only. If a reflecting galvanometer be enclosed in the circuit formed by the batteries and the tubes, the wave signals will be indicated by it.

Another method of producing an electric valve for separating the positive from the negative currents, is illustrated by Fig. 7, and consists in connecting, say, 5 cells of Daniell's battery with three cups containing dilute sulphuric acid with the platinum plates joined up so as to form three de-

## Statement of the case.

composition cells in series. Between the battery and the 3 cups is inserted the galvanometer or other instrument that is to be worked; the junction between the instrument and the cups or decomposition cells is connected to the condenser. The other junction between the battery and the decomposition cells is connected to the earth. The first action of the battery is to polarize the platinum plates, when the current almost entirely ceases, the 3 pairs of polarized platinum plates balancing the 5 Daniell's cells. The moment a current arrives from the condenser it finds two channels open to the earth—the one the battery, the other the decomposition cells. Suppose the positive pole of the battery to be in connection with the earth, and a positive current arriving from the condenser; at first it divides itself, part going through the battery, part through the decomposition cells. The action of the current upon the latter is to depolarize them; and they then immediately resist its flow. The next moment a negative current flows from the condenser, this negative current is assisted by the partly depolarized plates, and the battery and the former become repolarized. It is best to wrap the instrument, as the diagram shows, with two wires connecting the one with the cups, the other wire with the battery, and their junction with the condenser. The result is that whether it be a negative or positive current that is sent into this arrangement the action upon the instrument is the same, and thus out of alternating currents a continuous action is produced. The platinum plates for this purpose must be very small and very close together, to reduce as much as possible their inductive capacity and resistance.

Another method consists of inserting a reflecting galvanometer between the condenser and the earth (or between the line and the condenser); the vibratory or secondary signals can be read off by observing its tremor. The mirror of this galvanometer must be deadened by water or other damper, and it is best to produce the signals by interrupting the vibrations instead of the reverse. The vibrations keep the

## Statement of the case.

mirror oscillating, the image becomes spread out, and the light enfeebled. The moment the vibrations are cut off the light contracts. The effect is the "spread out" light is feeble, the "concentrated" is bright, and thus the signals can be flashed by long and short duration like the Morse alphabet.

Another method of utilizing these superposed vibrations is to connect to the condenser an electrometer like that of Milner or Pettier. A resistance coil of about 1,000 ohms is connected between the condenser and the earth as a shunt to the electrometer to prevent the Morse signals from affecting it to any sensible extent; or the wave signals may be read by the sense of touch. For this purpose I use a handle made of hard charcoal, and divided into two parts longitudinally. The parts are separated by a sheet of gutta-percha, and are connected, the one with the armature of the condenser, the other with the earth. The handle, being moistened and covered with a rag wetted with weak salt and water, is firmly grasped in the hand.

An intermediate Morse or other such line instrument would cut off the vibration signals or reduce them too much; this opposition or opacity of the intermediate instrument is destroyed by connecting the terminals of a condenser to the circuit on each side of the magnet. Thus, if I wish wave signals to pass a Morse instrument I couple the armatures of a condenser of 3 to 10 micro-farads with the line-wire, one on either side of the Morse instrument. The working of the Morse line, if there are many instruments in circuit, is also in this way improved.

There are several methods of producing electric waves in the lines in addition to that already described.

A tongue similar to those used in harmoniums is made to vibrate by air between contact-points, and so connect the condenser alternately with the battery and the ground, and so produce the alternations; or it may be made to connect the condenser alternately to the + or - pole of a battery whose opposite poles are connected to the earth.

## Statement of the case.

A magneto machine rapidly rotating will do the above duty equally well if its speed of rotation be controlled by a good governor.

The double-speaking apparatus of Dr. Gintl, or of Frischen, can be used on lines working with the above-described vibrations.

Fig. 8 is a diagram of this arrangement. *a* is the line-wire; *b, b*, the condensers; *c, c*, the cymaphens, wave signal transmitters, and parts connected therewith; *d, d*, are the current signal keys and batteries; and *e, e*, are the magnets of Dr. Gintl or Frischen's receiving instruments; and, *f, f*, are their resistance coils. I prefer wrapping the magnets *e, e*, with 3 or 4 wires, using one wire between the key and the earth through its resistance coil, and the 2 or 3 wires joined into one circuit attached to the line-wire. I insert a hollow helix between the double speaker and the line, and by putting iron rods in this helix the difficulty arising from the inductive capacity of the line is almost wholly removed; this is a new improvement and will render these apparatus actually useful instruments. The helix may conveniently be of No. 26 silk-covered wire and 10 inches long, with a diameter inside of  $1\frac{1}{2}$  inches, and outside of 4 inches; small iron rods are placed in this helix one by one until it is found that the finger-key does not affect the indicator of the home receiving instrument. By using these instruments, these apparatus together with cymaphens, as is shown in Fig. 8, three messages can be sent from end to end of such a circuit at the same time, independently of each other; for this purpose the cymaphen key must have a spring contact, so that the circuit between the condenser and the earth is never broken until the contact with the secondary coil is complete.

I would remark that in electric telegraphs the use of sound signals is not claimed by me, and is not new; for example, in working step by step instruments in which a pointer should indicate the desired letter on a dial, it has been common, when the instrument is out of order and fails to indi-

## Statement of the case.

cate correctly, to give sound signals; by its means such sound signals are read according to the Morse alphabet, a short sound, such as the escapement of the receiving instrument makes when moving a few steps only, representing a dot, and a long sound such as the escapement makes when moving over many steps, representing a dash.

Having thus described the nature of my invention, and the manner of performing the same, I would have it understood that I claim the construction of electric telegraphs in such manner that current signals and wave signals may be simultaneously transmitted through the same line-wire, and may be rendered sensible at the receiving station by separate instruments, the one sensitive to currents of appreciable duration, and the other to electric waves or vibrations.

I also claim the construction of electric telegraphs with, at the transmitting station, an instrument capable of originating in the line-wire a succession of rapid and regular electric waves, and at the receiving station a strained wire, a tongue, or such like instrument adjusted to vibrate in unison with the electric waves, and, being magnetized by them, oscillating to and from the pole or poles of a magnet in its vicinity.

I also claim in the construction of electric telegraphs the dividing a conducting wire into sections by instruments which I have called "echocyme," which allow current signals to pass freely, but stop wave signals, so that whilst the wire is being used as a whole for through signals, the sections into which it is divided may each or all be employed for the transmission of local messages.

I also claim the construction of electric telegraphs with, at the transmitting station, an instrument capable of originating in the line-wire a succession of rapid and regular electric waves, and at the receiving station a condenser consisting of thin sheets capable of being agitated by such waves.

I also claim the construction of electric telegraphs with, at the transmitting station, an instrument capable of originating in the line-wire a succession of rapid and regular electric



## Statement of the case.

waves, and at the receiving station an instrument which, on receiving such waves, delivers a current of electricity to an indicating or receiving instrument suitable to be worked with ordinary current signals.

I also claim the combination with Dr. Gintl and Frischen's double-speaking apparatus of a hollow helix connected between the receiving instrument and the line-wire, such helix having rods or pieces of iron inserted into it.

In witness whereof, I, the said Cromwell Fleetwood Varley, have hereunto set my hand and seal, this seventh day of October, in the year of our Lord one thousand eight hundred and seventy.

CROMWELL F. VARLEY. [L. s.]

The following, as to the meaning of some of the words employed in the Bell patent and in the art, is taken from counsel's brief in behalf of the Bell Company:

“SOUND-WAVES” AND “UNDULATIONS.”

When the wind blows on a sheet of water, waves rise on its surface; a chip dances up and down on the surface of these waves; a boat or a ship rocks, rolls and pitches by reason of them; painters draw, or try to draw, their contour—the line of their curiously-curved surfaces. But nothing of this sort takes place in the air where we are. We are not on the surface of the air. There is no surface to be thrown into waves and show a line. It is all about us; it always presses on all sides, but not always equally.

If you are in a tightly packed and excited crowd, you are pressed on all sides; but as the people in the crowd sway a little, you are sometimes jammed more tightly, and again presently have a little more elbow room. You and each of your neighbors touch each other all the time; but if the people in the part where you are move closer together, in their effort to see something, you are pressed a little more; if some of them are attracted to turn and move a little away from you, you are pressed less. These movements of greater or

## Statement of the case.

less pressure are due to a slight to-and-fro movement of the different individuals composing the crowd. Such is the case with the air particles. Under the influence of the voice or some sounding body, those immediately near it are first, perhaps, pressed together; presently, by virtue of their elasticity, they spring apart a little more widely than they were before, and thus zones of condensation or rarefaction are produced.

These zones of disturbance are propagated onward at the rate of about 1,120 feet a second, very much as sea waves are propagated onward, without any traveling motion of the air or water itself, and are called "sound-waves" or sonorous undulations. But as these zones are produced by, and correspond to, the slight vibratory motions of the air particles, it is found more convenient to study the motions of the particles themselves.

The Astronomer Royal (On Sound, by Sir George B. Airy, London, 1871) thus defined wave motion in 1871:

"We have states of condensation and states of rarefaction traveling on continually without limit in one direction, while the motion of every individual particle is extremely small, and is alternately backward and forward. And this is the conception of a wave as depending on the motion of particles in the same line as that in which the wave travels. This is the kind of wave which we shall consider as explaining the transmission of sound.

"But in all these there is one general character, that a *state of displacement* travels on continually in one direction without limit, while the motion of each individual particle is or may be small and of oscillatory character. And this is the general conception of a wave. It will be remembered that the special character of the waves of air applying to the problem of sound is that the displacements of the particles are in the same direction (backward and forward) as that in which the wave travels.

Such is the case with each air particle between the speaker

## Statement of the case.

and the listener, with the drum of the listener's ear, and with the elastic diaphragm of the telephone transmitter. The speaker's voice agitates the air, throws it into to-and-fro vibrations, makes the particles at each spot now to be more closely huddled together and now more widely separated,—that is, the air at each spot to be alternately more dense and less dense than it originally was,—and thus a diaphragm exposed to it is alternately pushed and pulled backward and forward.

“We must free our minds, therefore, from the notion of anything like a *continued onward flow* as a necessary concomitant of sound-waves, or indeed of any ‘undulations.’”

## “FORM” OF VIBRATION.

This phrase has nothing to do with the contour of a wave as a painter draws it. It is a purely technical term, used in a sense borrowed from a peculiar graphic, short-hand way of expressing the *character* of a vibration—the feature to which quality is due. This phrase, used in the patent, was devised and its meaning established long before the patent was drawn.

The following from Helmholtz, “Sensations of Tone,” pp. 28, 29, 32, (published in 1862), explains this:

“Human speech employs these very qualitative varieties of tone in order to distinguish different letters. \* \* \*

“On inquiring to what external physical difference in the waves of sound the different qualities of tone correspond, we must remember that the amplitude of the vibration determines the force or loudness, and the period of vibration the pitch. Quality of tone can, therefore, depend upon neither of these. The only possible hypothesis, therefore, is, that the quality of tone should depend upon *the manner in which the motion is performed within the period of each single vibration.*”

“Every different quality of tone requires a different form of vibration.

## Statement of the case.

(P. 100.) "To render the law of such motions more comprehensible to the eye than is possible by lengthy verbal descriptions, mathematicians and physicists are in the habit of applying a graphical method, which must be frequently employed in this work, and should, therefore, be well understood.

"To render this method intelligible, suppose a drawing point *b* Fig. 5, to be fastened to the prong *A* of a tuning fork in such a manner as to mark a surface of paper *BB*. Let the tuning fork be moved with a uniform velocity in the direction of the upper arrow, or else the paper be drawn under it in the opposite direction, as shown by the lower arrow. When the fork is not sounding, the point will describe the dotted straight line *d c*. But if the prongs have been first set in vibration, the point will describe the undulating line *d c*, for as the prong vibrates, the attached point *b* will constantly move backward and forward, and hence be sometimes on the right and sometimes on the left of the dotted straight line *d c*, as is shown by the wavy line in the figure. This wavy line once drawn, remains as a permanent image of the kind of motion performed by the end of the fork during its musical vibrations. As the point *b* is moved in the direction of the straight line *d c* with a constant

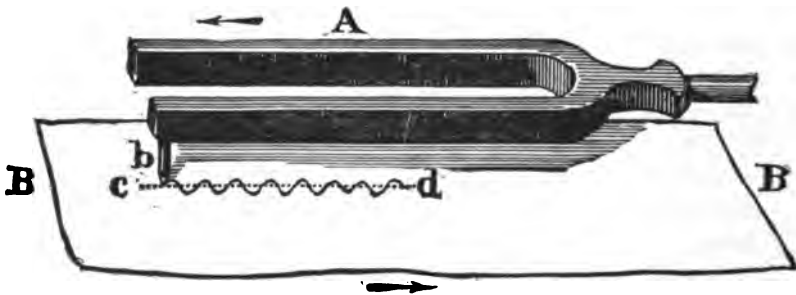

velocity, equal sections of the straight line *d c* will correspond to equal sections of the time during which the motion lasts, and the distance of the wavy line on either side of the straight line will show how far the point *b* has moved from

## Statement of the case.

its mean position to one side or the other during those sections of time.

“Physicists, then, having in their mind such curvilinear forms, representing the law of the motion of sounding bodies, speak briefly of the *form of vibration*, of a sounding body, and assert that *quality of tone depends on the form of vibration*.”

Physicists speak of the “form” of a vibration, meaning its character; not because it has “form,” but because the curve which represents it has.

The employment of this word “form” in the patent, in the scientific sense, since Helmholtz’s work became classic, implies *ex vi termini*, the element of “*quality*,” including articulation, especially when, as in the patent, reference is made to the utterances of the human voice.

It must always be borne in mind that the phrases “form of vibration” and “vibrational curves” do not signify the form of waves in the painter’s sense, nor yet any curved line which the vibrating particle describes or follows in the air. Thus the pendulum and the tuning fork simply swing to and fro.

The *form* of the vibration of the curve traced on the paper. The curve is merely a geometrical expression of a mathematical statement of the successive changes in velocity and direction at each successive instant, however minute. The sounding air particle simply moves to and fro in a straight line. The curves are in the geometrical statement of the changes in its motion.

In the sonorous vibrations of the air there are three characteristics which are so far independent of each other that each can be varied or altered without changing the other. They are, *period*, or frequency of vibration, signifying the time occupied in performing the whole complete vibration, starting from one end of the path, going to the other and returning to the starting point; *amplitude of vibration*, signifying the distance between the two extreme limits which the vibrating particle attains to; *character*, or technically “form”

## Statement of the case.

of vibration, signifying the way or manner in which the particle performs its vibrations. As expressed, and correctly expressed, in the quotations from Helmholtz, Donkin, Taylor and Dr. Seiler, the *period* of vibration corresponds to and determines the *pitch* of the sound; the *amplitude* of vibration corresponds to and determines the *loudness* of the sound; the "*form*" of vibration corresponds to and determines the *quality* of the sound, and "*quality*" includes articulate character.

It is true that any of the complex vibrations that constitute articulate speech and most sounds can be mathematically, and by special apparatus experimentally, resolved into the equivalent of one dominant fundamental sound or vibration, with which other sounds lesser and of higher pitch, or more rapid vibrations, are *blended*, so that the unaided ear does not distinguish them. But such a sound is, in the language of scientific acoustics, as in the ordinary habit of speech, considered a single sound. When we speak of it on the side of sensation we mean by its pitch, the pitch which the ear recognizes, and which is given to it by its fundamental or dominant constituent; when we speak of it on the mechanical side, we refer to it as a sound consisting of a number of vibrations per second which corresponds to what the ear so recognizes as the pitch; that is, the pitch of the fundamental tone,—in the case of a man's voice in ordinary speech about one hundred per second. And the other peculiarities, due to what are called the blended *overtones*, are referred to in the language of science, not as separate vibrations, but as elements which *modify the form of the vibrations* first spoken of. When, therefore, we speak of copying the number of vibrations, or reproducing the pitch of a sound, we refer, according to the established use of language at the time when Helmholtz wrote in 1862, and also at the time of the Bell patent, to the number of complete vibrations per second, corresponding to what the ear recognizes as the pitch of the sound. When we say that a vibration has received, either from the vocal organs or from the telephone, the special *form*

## Statement of the case.

of a particular uttered sound, we mean that the resulting sound copies, not in pitch or intensity necessarily or merely, but in *quality*, the character of the sound whose vibrations are thus copied, including the characteristics of articulate words. Such was the established significance of the terms.

## ELECTRICAL UNDULATIONS.

It is also one of the usages of science—and, indeed, of daily life—to represent graphically by curves successive values or intensities, like successive values at successive times of cotton, or gold, or other commodities, or the height of the thermometer or barometer on different days; and in this way, the same language which the science of acoustics adopted from the graphic method of representing sonorous vibrations by curves, is applied to all other reciprocating changes. The rise and fall of electric intensity at any particular point may thus be represented by a curve which will exhibit the precise *character* of the rise and fall, and, quite in accordance with the established use of the phrases, this rise and fall, if of a certain character, may be spoken of as an *electrical undulation*, the *precise* character of which will be expressed by the “*form*” of a curve actually drawn on paper, or which, if drawn, would represent it. Such electrical changes may thus be spoken of as *undulations* having particular *forms*.

The Molecular and Overland Companies introduced in evidence as anticipating Bell's 5th claim the following:

“*Translation from Work entitled ‘Der Electromagnetische Telegraph,’ by Dr. H. Schellen, 1867, pages 539–542.*”

“Fig. 375 represents the action of the electro-magnet E upon the printing mechanism of the apparatus, and also the device for coupling together the two parts *b* and *b'* of the printing axis.

“The cores of the electro-magnet are not connected together at the back by a yoke, as in the case of an ordinary electro-magnet, but as shown in Fig. 376, they are attached

## Statement of the case.

to the N and S poles of a powerful steel magnet. The action of this magnet upon the cores is regulated by means of an armature of soft iron placed on the legs N and S which can be moved up or down. The nearer it is placed to the end of the poles the less will be the magnetic effect upon the cores of the electro-magnet.

“By this arrangement the cores are constantly magnetic, and attract the armature *n* (Fig. 375), as long as no current passes through the coils. A strong steel spring *r* operating on the arm *F* serves by its attractive power to withdraw the armature when, by the passage of a current through the coils, the magnetic power derived from the steel magnet is neutralized. In order to avoid too strong an attraction, the armature does not touch the surface of the poles, but is separated by a space equal to about the thickness of an ordinary sheet of paper.

“When a current whose polarity is opposite to the polarity of the steel magnet is passed through the coils *E E*, the magnetism is weakened or neutralized, and it no longer holds the armature against the retractile force of the spring *r*, which immediately draws the armature upward with considerable power. This movement is communicated to the lever *d d'* which has its centre of motion at the axis *H*. One end of the lever rests, with an adjusting screw, on the top of the armature; therefore, when, under the action of the current, the armature is released and flies upward, one extremity *d* is raised with it, while the other goes downward, and it is by this movement that the coupling of the two portions of the printing axis *b<sub>1</sub> b'* (Figs. 369 and 370) is effected, and the motion of the wheel work transmitted from the pinion 5 to the front part of the printing axis *b'* and its four cams.

“The transmission of this motion is effected in the following manner: On the back part of the printing axis *b<sub>1</sub>*, a wheel *g* (Fig. 375), with very fine and strong teeth, is fixed. On the front part of the axis *b'* is a circular sector *l l'*, on



## Statement of the case.

one side of which is a flyer  $c'$ , to which is attached a detent  $c''$ . This detent has three teeth which gear into the teeth of wheel  $g$ . On the other side of the sector is a spring  $b$  which presses down the toothed detent, which, with its flyer  $c'$ , is allowed to rise and fall a little. When it is free, as represented in Fig. 375, the spring  $v$  presses the detent  $c''$  into the teeth of wheel  $g$ , and it revolves with the wheel in the direction indicated by the arrow, and thus the rotation of printing axis  $b_1$  at once effects the revolution of the circuit  $l'$  and the axis  $b_1$ . When, however,  $c'$   $c''$  is raised, its teeth leave the wheel  $g$ ; the latter continues to turn while the motion of the sector and the axis  $b'$  is arrested.

"The sector  $l'$  also carries an eccentric cam  $u$ , which raises the end  $d'$  of the lever, when by the action of the armature  $n$  it has fallen. This movement presses the armature against the poles of the magnet, where it remains attracted by the permanent magnetism of the cores so long as no current passes through the coils. When in the position shown in the engraving, the sector  $l'$  turns in the direction of the arrow, and after making half of a revolution the front part (in Fig. 375 the lowest part) of the cam  $u$  slides under the extreme end of lever  $d'$ . As the following end of the cam is more distant from the axis  $b'$  than the front end, the extreme end of lever  $d'$  is raised by the cam, the other end  $d$  consequently falls and the adjusting screw returns the armature to the poles of the electro-magnet.

"In the figure the front end of the cam  $u$  has not reached the end of the lever  $d$ , therefore this end is depressed, and the toothed detent is still engaged with the teeth of wheel  $g$ . When the axis  $b'$  is turned a little farther,  $d'$  will have reached its highest position, and  $d$  will be resting against the armature of the magnet. The axis  $b'$ , sector  $l'$ , and flyer  $c'$  continue to revolve; but when the revolution of the axis  $b'$  is nearly completed the flyer  $c'$ , to which  $c''$  is attached, reaches the inclined end of the arm  $d'$ , which is now firmly held, and moves upward, lifting  $c''$  out of the teeth of

## Statement of the case.

wheel *g*. By this the printing axis *b'* is disconnected from *b*, and the revolving wheel, work and its motion arrested, in which position of rest it remains until the arm *d'* again falls, owing to the release of the armature by a current passing through the coils, when the flyer *c'* is set free; *c''* again catches into the wheel *g*, and thus both *b'* and *b* are again coupled together. It will be seen that the printing axis *b'* makes a complete revolution at each action of the electromagnet, and that the movement of armature *n* and the release and action of the printing mechanism is effected exclusively by mechanical power, and not by the power of an electric current. The current, during its very short duration, merely weakens or destroys the permanent magnetism of the cores of the magnet, at which the spring *r* raises the armature *n* and through the lever *d d'* regulates the motion of the printing mechanism."

In the Molecular case and in the Overland case, the defendants alleged that claim 5 of Bell's second patent, No. 186,787, of January 30, 1877, is bad.

That it was a claim for a new kind of magnet, in which case it would clearly be bad, because the magnet had long been known. Such a magnet formed a part of the Hughes printing telegraph described by Schellen.

Judge WALLACE, in the Molecular case, stating that the claim had not been argued, held that the Hughes magnet was a clear anticipation. This decision was in June, 1885, and is here appealed from.

Subsequently, in December, 1885, on the hearing of the Overland case, it was pointed out to Judge WALLACE that the claim was not for the magnet *per se*, but for an improved form of telephone, made by taking out the magnet shown in Bell's first patent, and putting in this one. He at once perceived the misconception he had fallen into and sustained the claim, as appears from his decree.

Hughes, many years ago, invented a very ingenious printing telegraph. The plan was to have synchronously work-

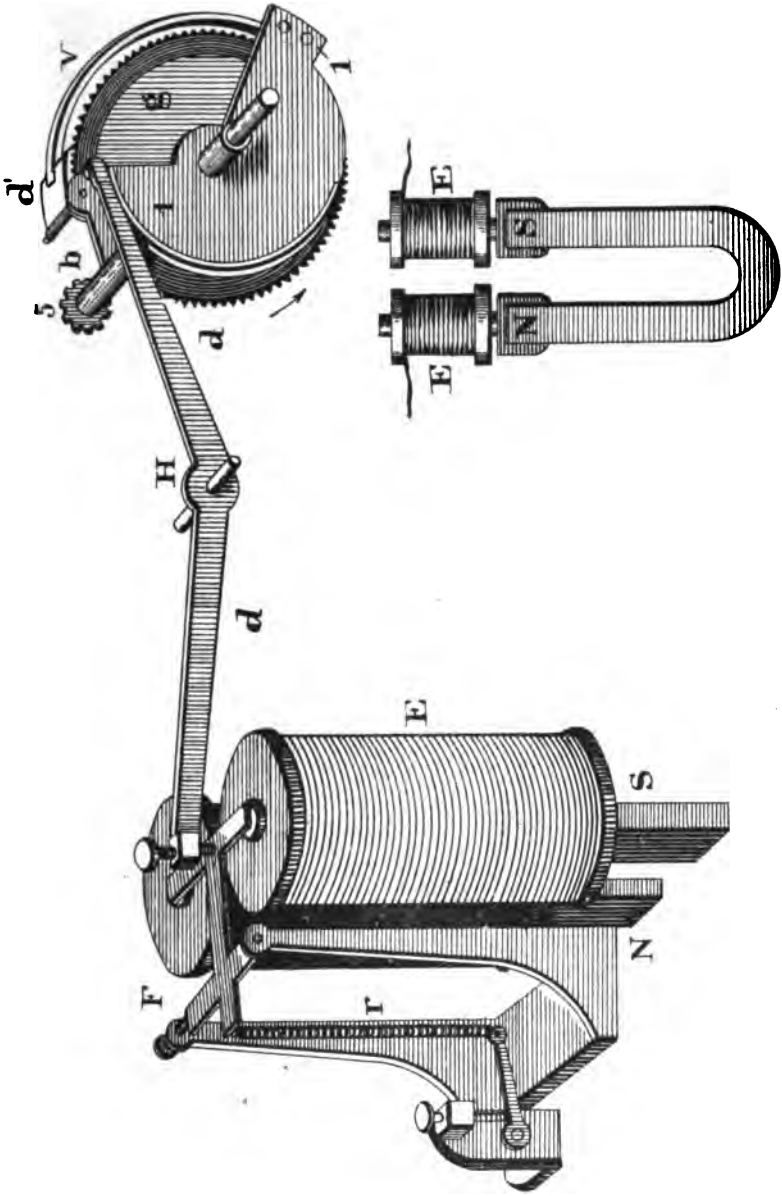



## Statement of the case.

ing clockwork at each end. When the key corresponding to a particular letter was pressed at the sending end, and the circuit closed, the current was used either to start or stop the clockwork, and consequently, the letter which was at the proper place in the moving machine just at that instant was caused to operate and make a mark. The whole work at the receiving station was done by clockwork, driven by a weight, and the function of the electrical current was merely to pull a trigger, and start or stop that clockwork at the proper time. This is the apparatus which is described and shown in the Schellen book.

In it Hughes employed the following device:

The horseshoe steel permanent magnet N S has mounted on each of its poles, N and S, a soft iron core, with a coil around it. The soft iron cores are not naturally magnetized, that is, they are neutral; but by being placed in metallic contact with the poles of the permanent steel magnet, which is permanently magnetized, these soft iron cores become, for the time being, magnetic by induction; and if a piece of soft iron, that is to say, an armature *n*, be placed in contact with the two upper ends of the cores of the coils E E, it will be held there by them by that magnetism. The soft iron armature *n* was laid by Hughes on top of the cores E E, with a retractile straining spring, shown as F and *r* in the drawing, tending to lift it away; but the strength of the spring was so graduated, by means of an adjusting screw, that it would not quite overcome the strength of the magnet. The armature was thus held, though with a nearly counter-balanced force, in contact with the poles of the two cores.

In the Dolbear case the final decree in the Court below was that the patent, granted to Alexander Graham Bell, by letters patent, No. 174,465, for improvement in telegraphy, dated March 7, 1876, is a good and valid patent, and that said Bell was the original and first inventor of the improvement described and claimed therein, and that the defendants had infringed the said patent; and a perpetual injunction was

## Statement of the case.

ordered. From this decree the defendants appealed. See 15 Fed. Rep. 438 for the opinion of Mr. Justice GRAY, and 17 Fed. Rep. 604, for the opinion of Judge LOWELL on final hearing.

In the case of the Molecular Telephone Company, the final decree in the Court below was that the several letters patent granted to Alexander Graham Bell for an improvement in telegraphy, No. 174,465, dated March 7, 1876, and for an improvement in electric telegraphy, No. 186,787, dated January 30, 1877, are good and valid; that said Bell was the original and first inventor of the inventions described in said several letters patent; that the defendants have infringed the 5th claim of said letters patent, No. 174,465, and the 6th, 7th, and 8th claims of said letters patent, No. 186,787. The defendants appealed from the decree; and the complainants also appealed from it "in so far as it fails to adjudge that the 5th claim of letters patent, No. 186,787, is good and valid in law, and that the defendants have infringed the same." See 23 Blatchf. 253.

In the case of the Clay Commercial Telephone Company, it was decreed in the Court below that the said patents were valid; and that the defendants had infringed the 5th claim of said letters patent, No. 174,465, and the 3d, 5th, 6th, 7th, and 8th claims of said letters patent, No. 186,787, and a perpetual injunction was ordered. The defendants appealed from this decree.

In the case of the Overland Telephone Company, the decree of the Court below was that the patents were valid; that said Bell was the original and first inventor of the inventions described therein, and that defendants have infringed the 5th claim of said letters patent, No. 174,465, and the 3d, 5th, 6th, 7th, and 8th claims of said letters patent, No. 186,787, and a perpetual injunction was ordered. The defendants appealed from this decree.

In the case of the People's Telephone Company (Drawbaugh case), the decree was that the said letters patent are

## Argument of counsel.

good and valid; that said Bell was the original and first inventor of the inventions described in them; and that defendants have infringed the 5th claim of said letters patent, No. 174,465, and the 5th, 6th, and 8th claims of said letters patent, No. 186,787, and a perpetual injunction was ordered. The defendants appealed from this decree.

[For further facts see the opinion.]

Counsel argued these cases orally in the following order:

(1) Mr. JAMES E. MAYNADIER, for Dolbear *et al*; (2) Mr. GROSVENOR P. LOWREY, for the Molecular Telephone Company; (3) Mr. LYSANDER HILL, for the People's Telephone Company (Drawbaugh case) and for the Overland Telephone Company; (4) Mr. JAMES J. STORROW, for the American Bell Telephone Company; (5) Mr. WILLIAM W. KER, for the Clay Commercial Telephone Company; (6) Mr. DON M. DICKINSON, for the People's Telephone Company (Drawbaugh case) and for the Overland Telephone Company; (7) Mr. GEORGE F. EDMUNDS, for the People's Telephone Company (Drawbaugh case) and Overland Telephone Company; (8) Mr. JAMES J. STORROW, for the American Bell Telephone Company (2d argument); (9) Mr. E. N. DICKERSON, for the American Bell Telephone Company; (10) Mr. CAUSTEN BROWNE, for Dolbear *et al*; (11) Mr. WHEELER H. PECKHAM, for the Molecular Telephone Company; (12) Mr. CHARLES P. CROSBY, for the Overland Telephone Company; (13) Mr. LYSANDER HILL, for the People's Telephone Company (Drawbaugh case) and the Overland Company (closing argument).

Messrs. JAMES E. MAYNADIER and CAUSTEN BROWNE, for Dolbear *et al*, appellants, filed a brief from which the following is taken:

Bell's 5th claim should be construed, in view of the state of the art, to cover only that method of transmitting vocal or other sounds telegraphically, which is described in his patent and illustrated in Fig. 7 of his drawings, that is, first, by causing the sound-waves to produce magnetic variations

## Argument of counsel.

and thereby electrical currents, alternately positive and negative, similar in form to the vibrations of the air accompanying the said vocal or other sounds, by reason of the fact that the positive currents represent condensations and the negative currents rarefractions, of the air, or *vice versa*; that the rate of change from positive currents to negative currents represents the rate of the air vibrations, and the intensity of each positive or negative current represents the intensity of each condensation or rarefaction. Secondly, after thus causing these peculiar alternately positive and negative currents, transmitting them to the receiver and there converting them into magnetic variations similar in form to these varying alternately plus and minus currents, and finally, by means of these magnetic variations, setting up vibrations in a distant air body, like the vibrations caused in the air body in contact with the vocal organs or other source of sound.

“The art of process” of transmitting articulate sounds by means of undulatory vibrations of electricity is not, and cannot possibly be, either an invention or discovery, for the reason that transmitting such sounds by means of such vibrations is a mere problem, not an art, or a process.

Certainly it is not invention, or discovery, to perceive that articulate sounds can be transmitted by vibrations of electricity, adapted in some way to do that work; and no man has shown any art or process of transmitting such sounds who has simply announced—what is entirely obvious—that electricity will do it, if adapted to do it; or simply announced the electrical and other conditions necessary to its being done.

Is not the 5th claim plainly void, under the authority of *O'Reilly v. Morse*, 15 How. 62 [5 Am. & Eng. 483]? It has always been held that the patent embraces nothing more than an improvement (*invention*) described and claimed as new, and that any one who afterwards discovered a method of accomplishing the same object, substantially and essentially differing from the one described, had a right to use it. And any one may lawfully accomplish the same end, without.



## Argument of counsel.

infringing the patent, if he uses means substantially different from those described.

The transmitting apparatus used by the appellants is the Reis transmitter, and the Reis circuit, and the Reis coil and core, except that the Reis circuit is very much shortened, and the electrodes are carbon, and not platinum; these changes are mere changes in details of construction, and the Reis apparatus taken as a whole, that is, transmitter, line and receiver, does not differ from the primary circuit of appellants' apparatus, except as an ill-made machine differs from a well-made one.

The coil and its core of the Reis circuit, as used in the defendants' apparatus, operate precisely as do the like parts in the Reis apparatus, with one exception, viz.: that the variations of magnetic energy induced in the core by the flowing of the varying current spirally around the core are converted into electric variations of a kind wholly unknown until they were discovered by Dolbear. These electric variations of Dolbear are produced by variations of magnetic energy in the core of a secondary coil; and, inasmuch as secondary coils containing a core whose magnetism is varied are old and well-known, it is clear that, speaking generally, the Dolbear variations are like the variations in other secondary coils; but there are, nevertheless, such marked and striking differences as make them radically new, and entitle them to rank as an invention second to none in question in this case.

Dolbear's method and apparatus are substantially unlike Bell's in all particulars. His method and apparatus are substantially like Reis's method and apparatus, except as to the secondary coil, the line-wire, and the receiver, and also the Dolbear secondary coil, line-wire and receiver are radically unlike anything in Bell's '76 patent, and radically unlike anything in any other telephone, and radically new with Dolbear.

The appellants earnestly urge this proposition:

That a secondary coil, one end of which is connected to a

## Argument of counsel.

wire, which wire is insulated, and has its free end enlarged, or, what is the same thing, electrically connected to an insulated plate or disc, is radically unlike a secondary coil and its core forming a part of a closed circuit.

The greater the variation of magnetic energy, the greater the number and better the arrangement of the convolutions, and the greater the external resistance between the positive and negative ends of the secondary coil, the greater will be the electric tension, pressure or head; and where the external resistance between the positive and negative ends of the coil is infinite, as it is in Dolbear's secondary coil, the maximum pressure possible is produced; whereas, in Fig. 7 of the Bell patent, and in the commercial telephone of the Bell Company, the resistance of the line and the helix of the receiver is slight, and must be slight, and, therefore, the electric tension, pressure or head never approaches the maximum. The secondary coils, best adapted for use in the Bell Commercial Telephone, are useless with the Dolbear receiver. There is a radical difference between the Dolbear coil, line and receiver, and the coil, line and receiver of the Bell 1876 patent.

Bell shows a generator capable of developing an electric condensation at one end, and an electric rarefaction at the other end; but these two ends are connected by an electrical conduit which prevents that electric condensation or rarefaction rising to anywhere near its maximum, because of the electric current which starts to flow through the conduit on the instant that any electric condensation or rarefaction commences.

In the Dolbear apparatus the generator is capable of developing electrical condensations and rarefactions measured by thousands, instead of hundreds, and there is no electrical conduit joining the ends of the generator.

In Dolbear there is an electrical chamber of high pressure, and an electrical chamber of low pressure, and the line-wire and the plate or diaphragm electrically connected with it always forms a part of one of these chambers, and never per-

## Argument of counsel.

forms the function of the line-wire and helix of the Bell line and receiver; that is, never serves as a conduit connecting the high-pressure chamber of the generator with the low-pressure chamber of the generator; nor does the line-wire and its plate or diaphragm perform any function at all like the function performed by the line-wire and helix of the Bell receiver. Moreover no one knew, until taught by Dolbear, that the electric pressure chamber, made up of the line-wire and plate of his receiver, could perform the function which it performs in his apparatus.

It is incapable of dispute that Dolbear is the first who ever made any practical application of static electricity; that is, who ever used electric tension, pressure or head, practically, for any purpose whatever, except only in the familiar way, to cause a current through an electrical conduit.

It is contended on behalf of the appellants:

I. That the Bell patent of 1876 describes and claims but one method of transmitting vocal and other sounds, which method is: (1) convert the energy of sound-waves into (2) magnetic energy; convert that into (3) vibratory currents of electricity; convert those into (4) magnetic energy; and with that cause (5) sound-waves; or briefly, (1) sound; (2) magnet; (3) currents; (4) magnet; (5) sound.

II. That Bell never invented, so far as appears from the record, any other method of transmitting vocal or like sounds.

III. That there is no hint or suggestion in Bell's patent of 1876 as to the employment of sound-waves to vary an electric current, nor any hint or suggestion that a current of unvarying polarity can be made capable of use to transmit vocal or or like sounds; but, on the contrary, that Bell in his '76 patent takes the utmost pains to teach (what he, in fact, discovered) that, in order to produce currents in a closed circuit, like in form to sound-waves, the currents must be alternately negative and positive; that is, to-and-fro currents, so as thereby to copy the to-and-fro motions of the air particles constituting the sound-waves.

## Argument of counsel.

IV. That Bell's apparatus is, in essence, (1) magnet; (2) coil; (3) closed circuit; (4) coil; (5) magnet; one magnet being supplied with the proper devices for causing the energy of sound-waves to vary the energy of the magnet, and the other magnet being supplied with the proper devices to cause its varying energy to produce sound-waves.

V. That Bell's patent of '76 does not cover either the Reis method or the Reis apparatus, but that the Reis method,—that is (1) sound; (2) current; (3) magnet; (4) sound,—and the Reis apparatus—that is, (1) a battery; (2) its circuit; (3) a transmitter-diaphragm, and the electrodes governed by it; (4) a helix; (5) its magnet,—are both public property: 1, because of the printed publications, so fully describing that apparatus that the Reis method will necessarily become familiar to any skilled person carefully studying the operation of that apparatus: and 2, because Mr. Bell carefully refrained from putting a single word in the specification of either of his patents which tended to show that the Reis current of unvarying polarity, but varying only in strength, was capable of being made similar in form to air-waves accompanying vocal or like sounds; and, by the very strongest implication, asserted in '76 patent that rapidly varying polarity was essential in order that the to-and-fro motions of the air particles of a sound-wave should be copied.

VI. That the battery, primary circuit, transmitter-diaphragm, its electrodes, and the helix and magnet in the primary or transmitter circuit of the defendants' apparatus, do not involve the method described and claimed in Bell's '76 patent, nor is the apparatus substantially the same as any apparatus described and claimed in Bell's '76 patent, but that this transmitter circuit and its parts are copied directly from Reis.

VII. That the Dolbear secondary coil, line and receiver is radically unlike anything described or suggested in Bell's '76 patent, and that the Dolbear method involved in its use with the Reis apparatus as a transmitter is radically unlike

## Argument of counsel.

any method described or suggested in Bell's '76 patent, and is also radically unlike any method of utilizing electricity ever known before Dolbear discovered his method and apparatus.

VIII. That the fact that in both the commercial telephone and the Dolbear telephone, the Reis apparatus is used as a transmitter circuit, in connection with a secondary coil which forms part of the line-wire, although, at first sight it may seem to make the Dolbear telephone substantially like the Bell commercial telephone in one important particular, yet it cannot have any weight whatever in view of the radical difference between the secondary coil and the line of the Dolbear telephone, and the secondary coil and line of the Bell commercial telephone, or the transmitting coil and line of Fig. 7 of Bell's patent; that is to say, Dolbear's secondary coil must be a generator of enormous electro-motive force, or electric tension, pressure or head, while the generator of the Bell produces relatively trifling electro-motive force or tension, pressure or head. An electrical conduit, joining the positive and negative poles, is essential to Bell, and fatal to Dolbear, and Dolbear's line and its connected plate are charged to a very high potential, tension, pressure or head, alternately positive and negative; and there are no currents, properly speaking, in the Dolbear line, but only such flow as is necessary to charge the line and the plate or disc connected with it.

IX. That wholly disregarding Reis, and assuming that Bell is the first in the field, yet the Dolbear method and apparatus are substantially unlike any method or apparatus described or claimed in the Bell patent of '76, for the reason that Dolbear does not utilize electrical undulations substantially the same as those described and claimed in the Bell patent of '76, but utilizes electrical undulations radically unlike any ever known until Dolbear discovered his method and apparatus; and for the reason that there is nothing in either the Dolbear method or apparatus copied from anything described or suggested in the Bell patent of 1876.

## Argument of counsel.

In the oral argument Mr. MAYNADIER further says:

I have prepared diagrams, in order that I may be more readily followed. The first diagram under the word "speaking tube" represents probably the first improved method of transmitting vocal and other sounds to a distance; and the method there consists *first*, of sound; *second*, an air column separated from the rest of the air; and *third*, sound. Those dots in the middle are a draughtsman's device for showing a long tube in a short space.

The second improvement over the natural method, and a very striking invention or discovery, is that shown in the mechanical telephone. There the method is *first*, sound; *second*, vibration of line; *third*, sound. The genius who invented that saw that he could set in vibration a diaphragm in one place (on the left of that in Fig. 2), and that that diaphragm would take up all the vibrations of the speech-waves.

His device was first, sound; by sound, I mean speech-waves or sound-waves of any sort; first, sound, which sound should, by its vibratory energy, its alternate condensations and rarefactions, set in motion a diaphragm, every condensation moving that diaphragm in one direction, and every rarefaction allowing it to move in the opposite direction, and thereby produce in that diaphragm a copy exactly of the vibrations of the air body, which vibrations were caused by his own vocal organs.

He said: "Now, how shall I make the vibrations of my first diaphragm cause like vibrations in a second diaphragm?" He said: "If I connect the two by a strained cord or wire, then the molecular vibrations of that strained cord or wire must cause the second diaphragm to vibrate just as the first vibrates." And he tried it and behold it was so.

The essential thing is that the two diaphragms must be connected by a strained cord or wire without break of any sort in it. The main interest of that Fig. 2 (the mechanical telephone in this case) is that here is an air body which is set in vibration by the vocal organs of the speaker, and

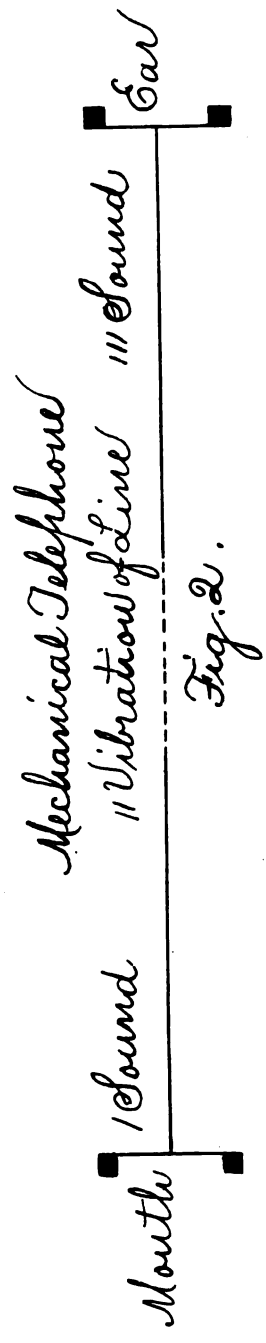
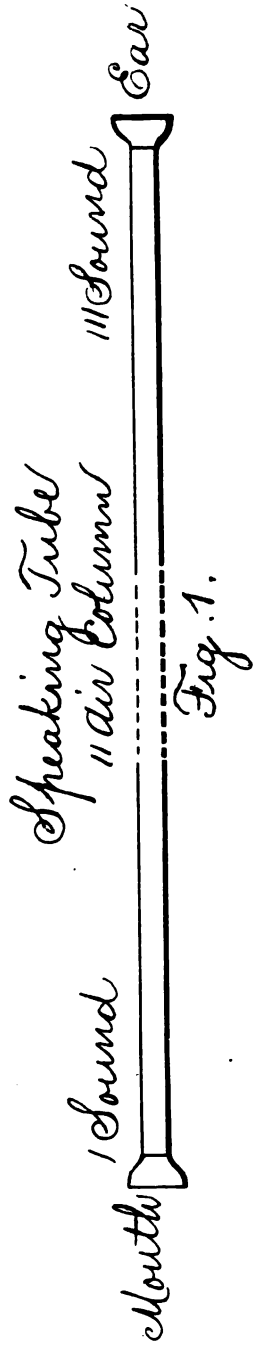
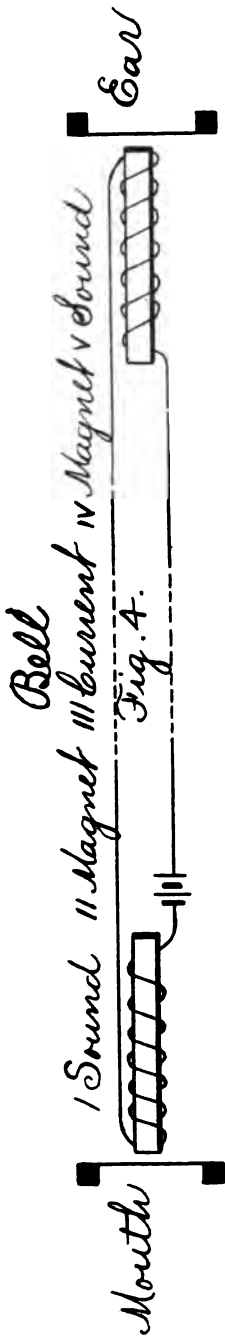

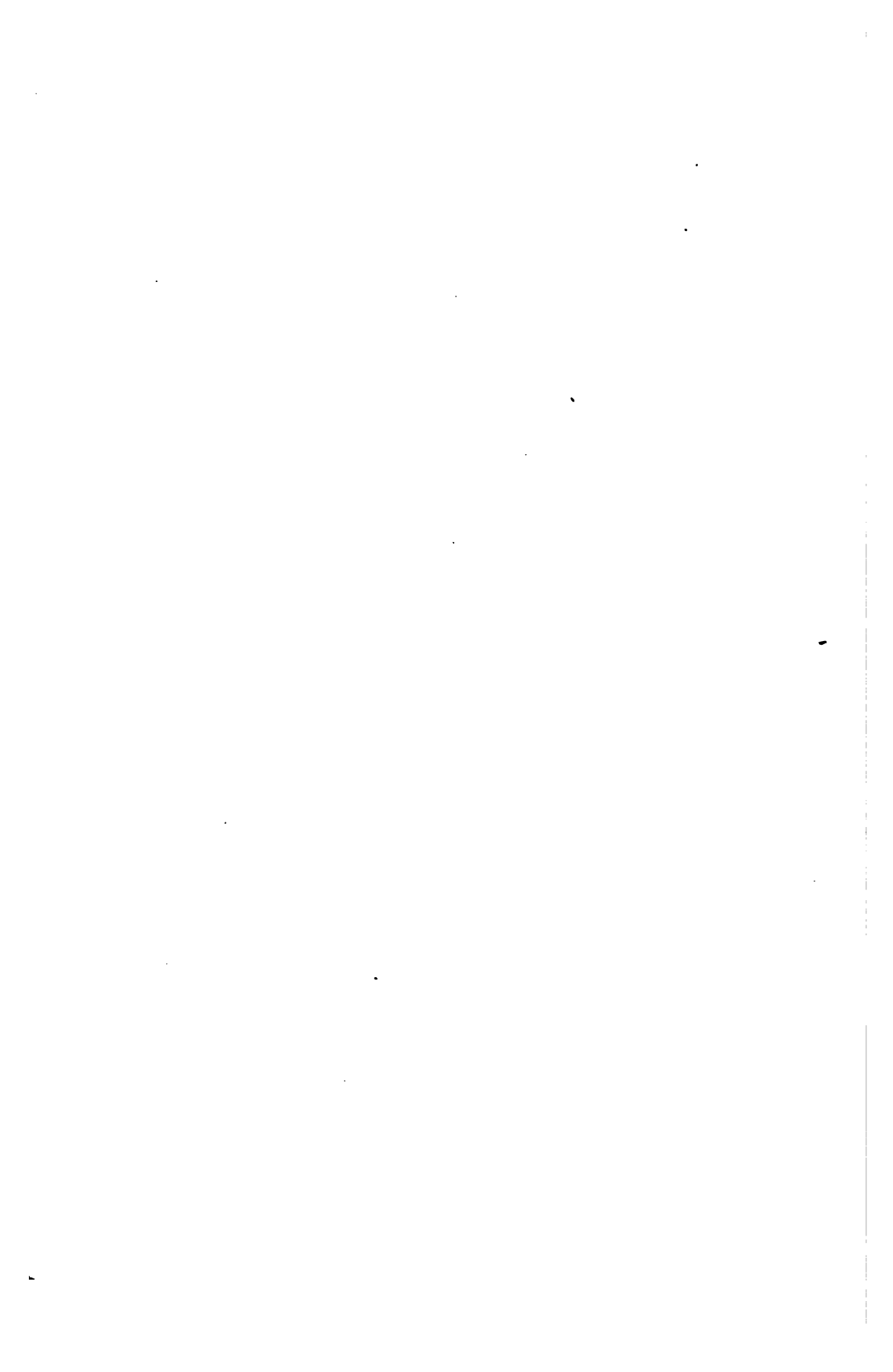



Reiss.

1 Sound 11 Current 111 Magnet 1V Sound Ear

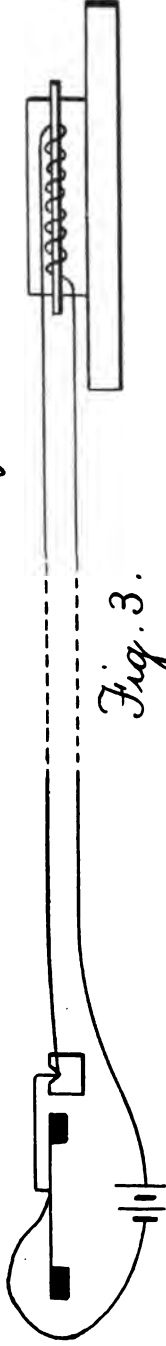

Fig. 3.

1 Sound 11 Current 111 Magnet 1V Tension 1V Sound

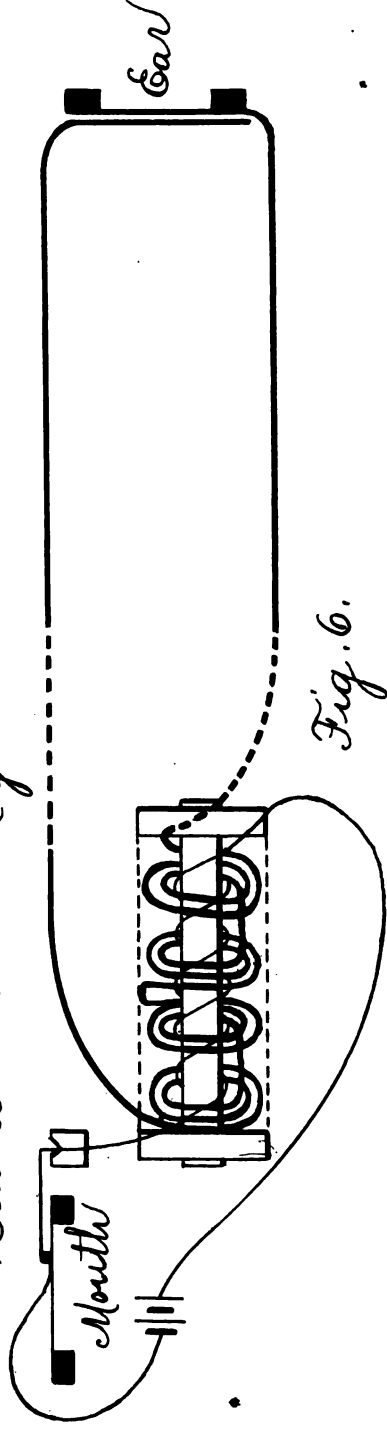
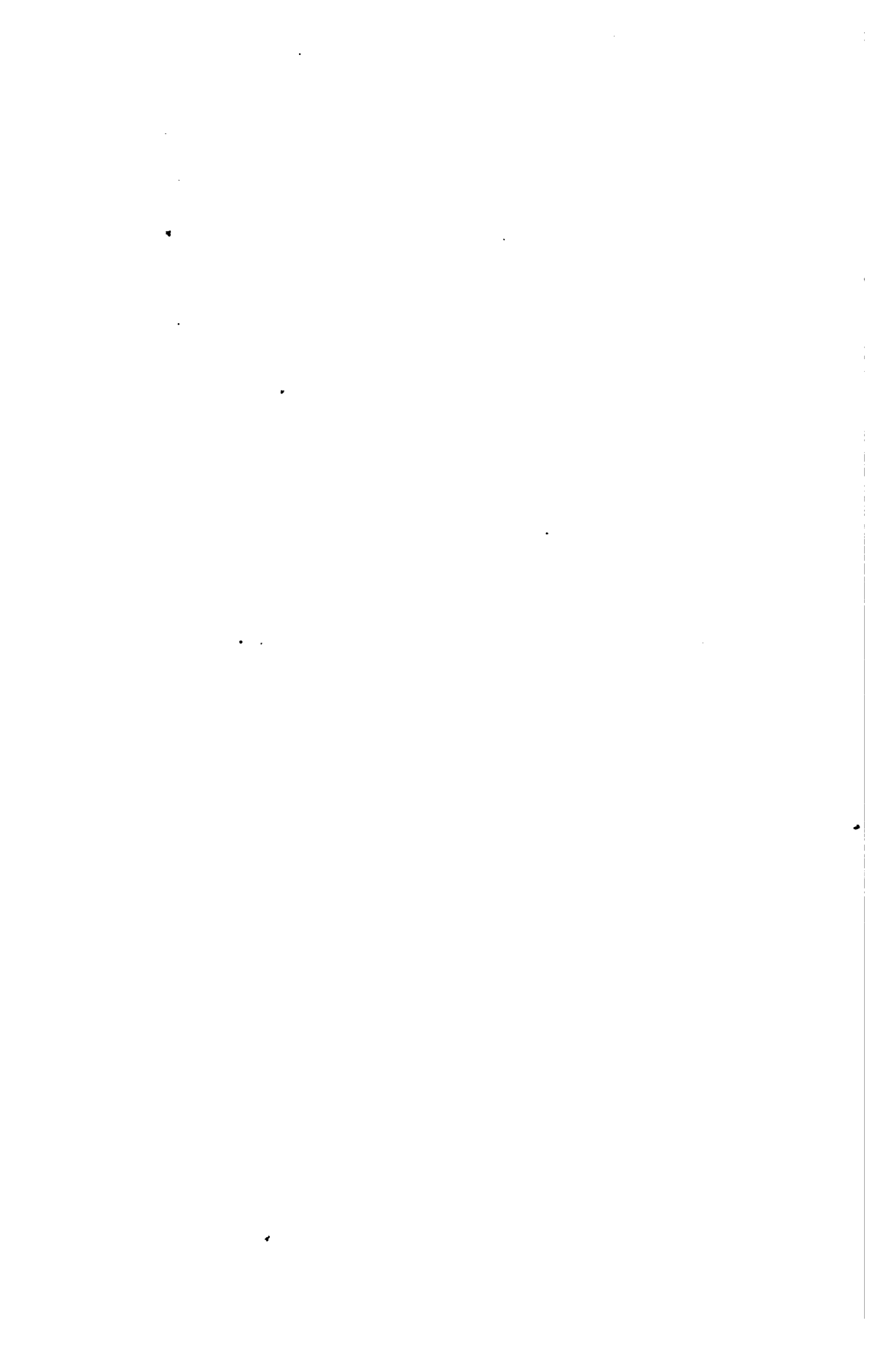

Fig. 6.



## Argument of counsel.

yonder, far off, is another air body to be set in motion. The vibrations of the first air body act upon a human contrivance which is so designed, so cunningly adapted for its work, that the vibrations of the first air body are caused to set up like vibrations in a distant air body. There is an invention or discovery—it is immaterial which, so far as I understand those terms—of a method of, and apparatus for, transmitting vocal and other sounds telegraphically, which is admitted to be very many years prior to any other now known.

The next attempt to transmit vocal or other sounds telegraphically, or to transmit speech, was made by Philip Reis, of Germany; and he devised the apparatus shown in Fig. 3 of my diagram. He adopted the general plan set forth in Fig. 2, namely: "I will set in motion by my vocal organs an air body in contact with my vocal organs, and I will endeavor to make those vibrations set up like vibrations in a distant air body." So his plan at base was the same as the plan of the mechanical telephone.

Reis clearly perceived this fact, that *every condensation and every rarefaction of the air-waves must be transmitted by a representative on the line, on his line-wire.*

The number of vibrations per second means pitch. Degree, amplitude of vibration, means loudness, and the quality so much spoken of in this case is nothing but a series of different degrees of pitch and loudness.

Reis did conceive the brilliant idea of controlling a voltaic current by the energy of air-waves. He was the first man in the world who ever spoke to an electric current, expecting to influence that current. That is a noble, magnificent invention; and when we consider that every telephone that was ever seen by any one has that precise feature in it, am I wrong in saying that Reis is entitled to as high praise certainly as Alexander Graham Bell, or any other man who ever made any claim—because there is no telephone known at this day, of any commercial value, which has not that feature copied servilely from Reis?

## Argument of counsel.

The transmitter of the Reis apparatus consisted of a chamber in the form of a box, which chamber of course contained air, just as the chamber of the ear contains air. The transmitter is shown in the diagram, on the left. The diagram represents a box which contains air, just as the chamber of the ear contains air. Mr. Reis thought, properly enough, that by speaking he would set in vibration the air within that box, and would thereby produce condensations and rarefactions of the air in that box, just as those same condensations and rarefactions are produced in the ear of the person who hears. On the upper part of the box there was a diaphragm mounted over a hole, so that whenever the air pressure inside of the box varied, the diaphragm would either bulge in or bulge out. That diaphragm carried a piece of platinum, and that piece of platinum was connected to one pole of a battery, as is shown in the diagram. The battery is shown on the diagram by two thin lines and two thick lines, which is the conventional or agreed way of showing a battery. Those are the perpendicular lines at the left-hand lower side of the diagram. That line leading from the black line is supposed to be a wire which leads around in a curve to the left, and then goes to the right, to the middle of the diaphragm. The diaphragm is the line directly above the word "mouth" between the two square black blocks. That is a diagram of a diaphragm. The wire leads to the middle of that diaphragm; and on the middle of that diaphragm there is a small piece of platinum. Then the other line leading from the middle of the diaphragm represents a carrier, an electrode carrier, which means a carrier of another piece of platinum, which other piece of platinum is connected to another wire by means of the block in white, directly underneath the word "sound."

That represents a solid block of say wood or metal, with a drop of mercury in a depression in the block; and one leg of that electrode carrier rests in that drop of mercury, and the other end of that leg rests by its own weight upon the

## Argument of counsel.

platinum carried by the diaphragm. Then, to follow the line from that drop of mercury, it goes to what electricians call "line,"—meaning the line-wire—to a coil at the right of the diagram. It goes over to that coil of wire. That coil of wire surrounds the core of metal; and the free end of that coil comes back to the battery, as the diagram illustrates.

The battery has two poles, which are commonly spoken of as the north pole and the south pole; just like a magnet, or the plus and minus ends of the battery. Whenever those two poles are joined by an unbroken wire a current flows from pole to pole. In the case of the Reis, the poles of the battery are joined by that wire when the apparatus is in action, and there is a current flowing from pole to pole of the battery. That current is a constant voltaic current, or battery current. That is a voltaic battery and the current is commonly called a voltaic current, or a battery current. That current is practically a constant current.

Mr. Reis reasoned that every condensation in the cubical box of his apparatus would bulge out of the diaphragm, and every rarefaction would allow the diaphragm to move back. That is, when the speaker spoke the column of air next his vocal organs would be pushed, and allowed to vibrate; and consequently the other end of that column which rests in that cubical box would push upon the diaphragm and relax its pressure, and thereby vibrate the diaphragm, just exactly as the air vibrated in the column.

The Reis diaphragm will follow and copy exactly the vibrations of the air particles. The appellants maintain that Reis intended to produce a variation in the current for every variation in the pressure of the air within the cubical box. They also maintain that anybody who succeeds in doing that will transmit speech electrically, to that extent.

Then the two pieces of platinum are what are called electrodes, which means simply a gate, or way, or door, for the current to pass through.

One piece of platinum is fast to the diaphragm, and the

## Argument of counsel.

other piece of platinum is fast to that electrode carrier, one end of which is in the drop of mercury.

The electric current flows through the wire and especially flows through those two pieces of platinum, which are in contact before you begin to talk. When you begin to talk the vibration of the diaphragm so affects the contact of those two pieces of platinum, that Reis supposed that the current would be varied as the condensations and rarefactions of the air took place. He intended to transmit a current, for instance, for every condensation, and to break the current for every rarefaction of the air. For every forward motion caused by pressure under the diaphragm he intended to make or break (it is immaterial which) the current; and for every backward motion he intended to make or break (it is immaterial which) the current; and the current was to do the work. If, therefore, there were one thousand motions of the diaphragm up, and one thousand motions of the diaphragm down, per second, he was to have one thousand electrical impulses going over the line-wire, and one thousand cessations of electrical impulses over the line-wire, per second.

It was the first attempt at any method for the transmission of speech telegraphically, by the electric current. Reis made many forms of apparatus, and achieved more or less success in his efforts. What degree of success he achieved it is not important for me now to inquire, because that matter is left to other gentlemen. All that I care to say about Reis is that he showed a method of, and an apparatus for, transmitting sounds, which method consisted in, *first*, sounds; *second*, a current,—a varied current; *third*, a magnet to utilize the varying energy of the current; and *fourth*, sound reproduced by the varying energy of that magnet.

An apparatus made by Reis, and fully described in many printed publications, and in several different languages, was thoroughly well-known among scientific men long before 1874, when Mr. Bell dates his invention I believe, and long before 1876, certainly, when he got his patent.

## Argument of counsel.

The Reis apparatus does not differ in any way whatsoever from the present transmitting apparatus in the commercial telephone, save and except only as an ill-made sewing machine, for example, differs from a well-made sewing machine on the same principle.

Fig. 5 of the diagram shows the commercial telephone as now in use. The diagram is a fac-simile of the left-hand side of the diagram Fig. 3, which shows the Reis apparatus. There is a short Reis circuit shown in Fig. 5. Reis used two pieces of platinum on the left of Fig. 5, a black mark above the middle of the diaphragm indicates a piece of carbon. Carbon turns out to be far better adapted for that use than platinum.

The transmitting apparatus used by this defendant, Dolbear, is a fac-simile of the Reis apparatus, excepting only that a piece of carbon is substituted for one piece of platinum.

Fig. 6 is the Reis-Dolbear apparatus. The transmitting apparatus of the Bell telephone is a servile copy of the Reis apparatus; it is simply an improvement, a mechanical improvement, of the Reis apparatus.

When used in a certain, particular manner, the apparatus as made by Reis, without change of any kind, will transmit speech. If you modulated your voice properly you could transmit words and sentences through the Reis apparatus, just exactly as Reis left it, without change of any sort.

The Bell patent is shown in the diagram, marked Fig. 4. There is on the left a magnet, and on the right a magnet, each magnet being in a coil of wire, and that coil of wire having its ends joined together so as to make a complete metallic circuit for the battery current which flows from the battery. When a current flows from the battery it flows spirally around those two pieces of iron, commonly called cores, and that makes them magnets. So, there are two magnets, one on the left and the other on the right, and each magnet has a coil of wire surrounding it, and those coils are joined electrically together so as to make one circuit.

## Argument of counsel.

One coil is a transmitter, and the other is a receiver coil. But either coil is a transmitter, and either is a receiver, as it may be. Opposite each magnet there is a diaphragm, which diaphragm is made of iron in the diagram. It was known long before Bell's time that if you move a piece of iron towards a magnet, which magnet had a coil of wire around it, you would thereby induce an electrical current in that coil of wire. If you moved it away from that magnet, you would thereby induce a contrary current in that coil of wire.

Bell's method, in his patent of 1876, is: *first*, sound; *second*, magnet; *third*, currents (in the plural) vibrating alternately from left to right and from right to left; *fourth*, magnet; *fifth*, sound.

That is the full length and breadth of this claim, and nobody can infringe the Bell patent unless you find in the alleged infringing method: *first*, sound; converted into, *second*, magnetic energy; that converted into electric currents; those currents converted again into magnetic energy; and that second magnetic energy converted into sound-waves.

When the Reis-Bell is operated, what happens is that the energy of the sound-waves, acting upon the Reis diaphragm, varies the energy of the left-hand magnet, just exactly, in substance, as the energy of the sound-waves acting upon the diaphragm, in Fig. 4 (Bell), varies the energy of the left-hand magnet. That varying energy of that magnet sets up those precise currents of Bell in the line-wire. Those currents traverse the circuit just as in Bell. Those currents influence the right-hand magnet just as in Bell; and that right-hand magnet causes the second diaphragm to vibrate just as in Bell. So, the Reis-Bell method is: *first*, sound; and then, *second*, the Reis current; but that current is used to vary the energy of a magnet merely, which magnet induces these vibrating plus and minus currents, which are precise fac-similes of Bell, differing solely in degree. They are stronger and better adapted for the purpose; otherwise they resemble Bell's currents exactly. The interposition of a



## Argument of counsel.

magnet, or of a half dozen magnets, does not alter the principle. It does not alter the method in any way.

An induction-coil is shown in the diagram in Fig. 5 and Fig. 6. The induction-coil is a core of soft iron, with a coil of wire around it; and that coil of wire is connected to a battery, so that the current will pass through that coil—that primary coil. There is another coil of wire around the first coil, and that secondary coil is the induction-coil, because whenever the magnetism of the core varies a current is induced in that secondary coil. In practice, the secondary coil is larger, a good deal, than the primary coil.

In Fig. 5, one of the coils goes to line, and is in circuit with the right-hand magnet, while the smaller coil goes to battery, so that the current from the battery flows through the electrodes, governed by the diaphragm, through a short circuit, and through the small coil back to the battery again.

All that the electricity does is to vary the magnet in the secondary coil, and, as the magnet in the secondary coil varies, currents are induced in that coil by the variation. Professor Wright took a Reis instrument, and prepared it as shown in Fig. 5, except that he had no magnet on the right hand end of Fig. 5, but he had what is called a condenser.

Mr. Elisha Gray and Mr. Varley also transmitted the pitch of a tuning-fork and other sounds; but they did not attempt, apparently, or succeed if they did, in using the energy of the speech-waves to set the apparatus in motion.

The defendant's apparatus I have called the Reis-Dolbear; that is Fig. 6 of the diagram. It will be seen by the diagram that the energy of the air-waves acts upon the diaphragm which we say is a fac-simile of the Reis diaphragm; that the vibrations of the air-waves move that diaphragm just exactly as they do in Reis; that the diaphragm controls the voltaic or battery current just exactly as in Reis; and that variations in that current, caused by the varying pressure of the electrodes one upon the other, vary the magnetic energy of a magnet, just exactly as in the commercial telephone.

## Argument of counsel.

The first step in the Bell method is the varying, by force of the air-waves, or of the sound-waves, of the energy of a magnet. Dolbear's first step is much the same. But here the resemblance ends. That is the only likeness—the sole likeness—between the Bell method, as I have described it, and the Dolbear method. That is, that the energy of the air-waves in both may properly and fairly be said to vary the energy of the magnet. Now, how to utilize that varying magnetic energy. Bell utilized it by producing plus and minus currents. Dolbear produces no currents whatever, on the line. He produces simply variations of electric pressure, or in electric tension, or electric condensations and rarefactions.

The Dolbear line is an open circuit, of necessity. The Bell line is a closed circuit, of necessity. That is a radical difference. The electric condition of the Dolbear line is radically unlike that of Bell; and the Dolbear receiver is radically unlike that of Bell, and is not a known substitute for Bell's receiver, but wholly unknown, and not in use for any purpose whatever until Dolbear's discovery that that contrivance would produce speech.

In Fig. 6 the secondary coil is very much larger than in Fig. 5. That secondary coil is the generator of the electro-motive force. Electro-motive force means electrical pressure, tension, or head.

To that plus end of the coil a wire is attached; to that minus end of the coil a wire is attached. So far it is exactly like Bell's. But those wires do not join anywhere, do not touch, are not in electrical contact anywhere. They must join, they must touch, they must be in electrical contact in Bell. In Bell they must be joined by a coil. Why? Because the current must flow spirally around the soft-iron core. In order to do Bell's work they must flow from left to right, and again from right to left, rapidly alternating.

Dolbear relies upon electrical attractions pure and simple. That feature of what is called electricity is what Dolbear has

## Argument of counsel.

utilized, and utilized for the first time in the world for any purpose whatever, excepting only in the laboratory. It is, therefore, not a known substitute, or anything like a known substitute for the way in which Bell used electrical currents. This condenser differs from any other condenser ever used for purposes of sound, in that way.

If it be true that the Bell method is, *first*, sound; *second*, magnet; *third*, currents; *fourth*, magnet; *fifth*, sound—then it seems to follow, without need of any other or further argument, that the Dolbear method does not infringe.

It is true that in the Dolbear method a voltaic current is made similar in form to sound-waves, by the energy of the air vibrations in the transmitter, but that voltaic current is not utilized to transmit speech, but only to vary the magnetic energy of a magnet; and that varying magnetic energy is utilized in Dolbear in a way radically unlike any way ever known before; and especially unlike anything ever pointed out by Bell.

All that Dolbear uses in his secondary coil and line are variations of electric pressure; and those variations of electric pressure do not produce currents, as in Bell; they are not for the purpose of producing currents, but they are simply variations in electrical pressure. And it is undisputed, practically, in this case that no man before Dolbear ever had any conception whatever of any such electrical variations, or of any way of using them.

Dolbear had just as good a right as Bell to find out a method of transmitting speech telegraphically by electricity. Dolbear has made an independent invention and discovery radically unlike anything shown to him by Bell, radically different from anything suggested or hinted at in Bell, and, like Bell, only in the ultimate result.

The electric pressure in the Bell line is meant to do nothing but make a current.

A conduit connecting the two ends of the generator is the

## Argument of counsel.

very essence of Bell; but there is no conduit, or anything resembling a conduit, in Dolbear.

In the speaking-tube the mouth vibrates one end of the air column, and the ear is at the other end of the air column. There is no motion of the air from the mouth to the ear, but only a vibration of the entire column. Therefore there is a pressure, and a less pressure and a greater pressure, and a constantly varying pressure, in the chamber of the ear. And absolutely all that speech consists of are those vibrations of pressure upon the drum of the ear.

The commercial value of Bell's invention was trifling, because of the weakness of the currents. In the course of time other inventors added to that of the Reis apparatus; and 97 per cent. of all the modern telephones of to-day, now in use, are in fact the Reis-Bell telephones, and are not the Bell telephones. That is Fig. 5. That is to say, the transmitting portion of every commercial telephone has been a servile copy of the Reis apparatus, and the rest of it a copy of the Bell apparatus.

The Dolbear telephone is not the Reis-Bell, but is the Reis-Dolbear.

Messrs. GROSVENOR P. LOWREY, WHEELER H. PECKHAM, and H. D. DONNELLY, for the Molecular Company.

"Vocal sounds" and "articulate speech" were not convertible terms in the telegraphic art at the date of Bell's patents.

The "vocal sound" of multiple telegraphy was understood to be a mere musical note, sounded at an agreed pitch, and had no reference to articulate sounds.

*Vocal sound* is the utterance of a sound of voice, and is common to all animals who possess the organ of voice.

Articulate speech is the *series of sounds and notes uttered in arbitrary sequence to express ideas.*

The art of reproducing, in any manner, vocal or other sounds and articulate speech is one art.

When the reproduction of either class of sounds employs

## Argument of counsel.

the electric current, the natural *modus operandi* is that changes in the strength of the current occur, which, in degree and rapidity of succession, correspond substantially to the air vibrations of the specific sound or sounds being transmitted. These changes are now commonly called undulations.

There are only two ways or "methods," so far as is yet known, for producing the changes of current needed in the practice of the art of reproducing or—as it is erroneously called—transmitting sounds telegraphically, viz.:

1. By varying the initial or electro-motive force of a current.

2. By varying the resistance to the flow of a current, without varying its initial or electro-motive force.

These two ways of producing the needed changes constitute two *distinct and different methods* of practicing the art of "transmitting vocal or other sounds" (and also articulate speech) telegraphically," by causing electrical undulations similar in form to the vibrations of the air accompanying the sounds.

The first method is that figured in Mr. Bell's patent by a drawing. By this method the efficient current—that is, the particular current which affects the receiver—is generated in the transmitter by magnetic action; and is efficient by reason of variations in its *initial* force, called electro-motive force.

This is called the *magneto method*.

When, instead of a permanent magnet, a battery is employed to magnetize the magnet it is called a *magneto-electric method*. The second method is that employed by the defendants and by the complainants.

By this method a current of constant electro-motive force is generated in a chemical battery, and is made effective for work in telephony by the introduction of a varying degree of resistance to its flow through the circuit; which variation of resistance may meet it anywhere between the battery and the receiver.

## Argument of counsel.

This is the variable resistance method.

1. The variable resistance method requires, like the magneto-electric method, but one circuit, although two circuits, called primary and secondary, are used in commercial business, where places, more than say one-half mile from each other, are to be connected. The explanation now to be given will, for greater simplicity, describe the transmitter as an element in one single circuit, consisting of battery, transmitter, receiver and the necessary connecting wires.

The Blake transmitter, being the one chiefly used by the defendants, and therefore more commonly known than any other, will be adopted as the example by which to illustrate the mechanism and method of operation of the class of transmitters to which it belongs, and which are popularly called microphones.

The function performed by this transmitter is to interpose a resistance to the flow of current from the battery through the circuit above described, which may be made to vary. This it does by means of a piece of carbon *c* and a piece of platinum *d*, which are held in normal contact by two springs *f* and *e*, and from one to the other of which, through the platinum and carbon contact, the current must pass. The pressure of the springs is subject to be disturbed by many causes—even by the jar of a sound made in the neighborhood; and the resistance between the contact-points, *c*, *d*, is varied as this pressure is varied.

The Blake transmitter consists essentially: (1) of a flat piece of thin board *aa* with a small round hole in the middle; (2) a ring of cast iron screwed to one side of the board, carrying a cross bar or spring lever *b*, to which near its upper end is fastened a square block of non-conducting material; (3) a thin light spring *e*, one end of which is inserted into the block of non-conducting material, and the other end of which hangs down opposite to the hole in the centre of the board, and carries on each of its faces a small point of platinum *d*; (4) another but stiffer spring *f*, the upper end of

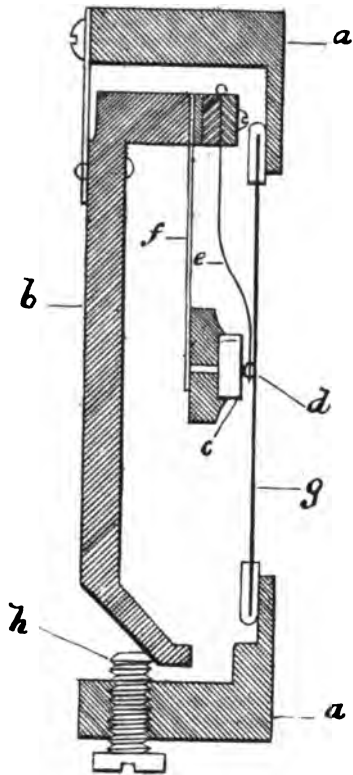





## Argument of counsel.

which is in like manner inserted into the block of non-conducting material, carrying upon its lower end—which hangs parallel to the first mentioned spring—a piece of carbon *c* on face next to the other spring; (5) a piece of thin metal called a diaphragm *g*, which is fastened at its edges to the iron ring—though insulated from it—so as to close the small hole in the board on the side next the springs. The cross bar or spring lever is subject to adjustment by a screw *h*, which bears against its lower end so that that end may be pressed in towards the stiff spring which is parallel to and next it. The tension of the two springs above described is such that they press lightly against each other—bring the piece of carbon *c* on the stiff spring into contact with the platinum point *d* on one face of the lighter spring—and also press the platinum point on its other face against the diaphragm. A battery is connected by a wire to the upper part of the stiff spring; another wire is connected to the upper part of the light spring, and is led thence to the required distance where it is connected to a telephone receiver (assuming that no secondary circuit is used), and is carried thence to the ground or back to the battery, thus making a complete circuit over which an electric current may flow. The course of the current is: (1) from the battery to the stiff spring *r*; (2) down that spring to its lower end; (3) through the carbon *c* block of that spring, to the platinum point *d* of the other spring; (4) through that platinum point to the light spring *e*, and (5) up that spring to the place where the other wire is attached; (6) thence through that wire—called the line, or line-wire—to the receiver; (7) and through the receiver to the earth or by another wire back to the battery. The contact of the platinum points with the diaphragm on one side and the carbon point on the other is such that even the slightest jar will cause the platinum and carbon to be pressed more closely together, or driven measurably apart. A strong jar (such as results from too loud speech in front of the diaphragm for instance) may, when they are properly adjusted for transmis-

## Argument of counsel.

sion of sound, cause them to be for a very brief period, say for the  $\frac{1}{1000}$  part of a second, and for a brief space, say for the  $\frac{1}{1000}$  to  $\frac{2}{1000}$  of an inch, to be separated. Such a separation, being regarded prejudicial to the transmission of speech, is sought to be guarded against by an adjustment of the screw and cross-bar; and also by an avoidance of too loud speaking.

The apparatus being set up, a current is permitted to flow from the battery through the circuit. This it does by reason of what may be considered as a force behind it, resulting from the interaction of the elements of the battery. This is called electro-motive force. It is not a force of the current, but of its generating source; something which compels the production—at places distant from the battery, but connected with it by a conductor—of phenomena which are attributed to a force originating in the battery. In ignorance of what does actually occur, the supposed transference has been likened to the flow of water, and, for want of any better term, the electrification of the conductor has been called a current. The only thing known is, that when the elements of the battery are permitted to act, certain phenomena occur throughout the entire circuit—however long it may be—at almost the same instant, so that, if the battery be in New York, the phenomena of electrification can be made to appear in San Francisco in about three-tenths of a second.

This flow meets a resistance in the circuit which can be definitely measured and stated; and which can be increased or decreased in various ways. One way is to increase or decrease the cross-section of the conductor at some point, thus narrowing the path for the current; as if a flexible tube, through which water is flowing, should be compressed by the hand. If, now, we suppose the diaphragm of a telephone transmitter to be vibrated by speaking before it, it will press inwards, thus driving the light spring back and pressing the platinum more against the carbon. This pressure brings many molecules—perhaps many millions—into actual con-

## Argument of counsel.

tact, which were not in contact before. This increase of contact enlarges the cross-section of the conductor at that point; widens the path of the current, and the resistance to its flow is proportionately *diminished*. When the diaphragm reacts it relieves this pressure; there is a diminution of contact, the cross-section is diminished; the path is again narrowed and the resistance *increased*. If this variable contact is made correspondingly to the rarefaction and condensation of air constituting sound waves, the current is said to be "moulded" into the form of the sound-waves; and, by help of other arrangements in the receiver, speech is reproduced.

This way of reproducing sounds is called *the variable resistance method*, and a transmitter thus operating is called a variable resistance, or variable contact, transmitter.

Such a transmitter is *incapable of acting by the magneto method*; as a magneto transmitter is incapable of acting by this method.

The changes in current strength being called undulations, the current in which they occur is called an undulatory current.

*The essential characteristics which distinguish this method are, that the constant is a voltaic current originating in a battery, disturbed by variation of resistance,—thus creating an undulatory current of electricity,—and that the source of efficiency is the battery.*

*Bell's Magneto-Telephone and its Methods.*

The instrument figured and in part described by Mr. Bell in his patent of 1876, No. 174,465, is shown in the following drawing:

It will be seen that a battery is represented, which is the source of voltaic electricity flowing freely from the battery through a wire which leads to the transmitting apparatus, which it enters by winding about a short piece of soft iron *b*, the convoluted parts being insulated from each other and from the iron core by a silk covering. The wire, *e*, having been sufficiently wound around the soft-iron core is led away

## Argument of counsel.

to the distant receiver, where it is wound about a similar soft-iron core *f*, and thence to the earth—thus completing the circuit with the battery. This core and single coil constitute, when a current is flowing, an electro-magnet, which is not, however, to be confounded with an *induction coil*. There is but one circuit; and that extends from battery to receiver—however great the distance. In its course the current meets normally no changeable resistance.

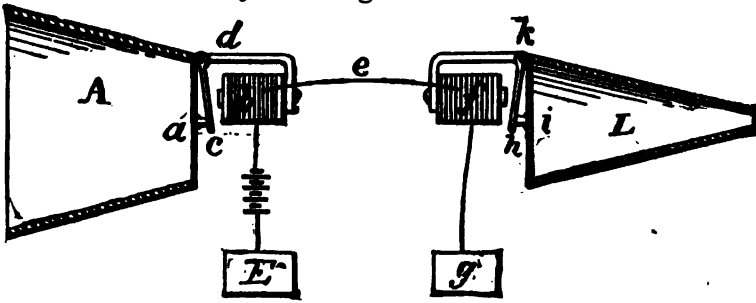

The figure shows a cone, *A*, one end of which is covered by a membrane *a*, to the centre of which, on the side next to the coil, is attached a metal armature *c*, which is an inductive body when itself magnetic, or when the core of the adjacent coil is magnetic. At the other and receiving end of the line is seen a similar arrangement of armature, membrane and cone, *h, i, L*, except that the end of the receiving cone is made smaller for convenience in hearing. If, now, the battery current begins to flow, it passes through the wire wound around the soft-iron core *b*, and over the line *e*, on to the second series of convolutions around the second soft-iron core *f*, and thence to the earth. In obedience to well-known laws of electro-magnetism, in passing around them it causes each of the soft-iron cores to become magnetic, and so remain, so long as the current is flowing. If, now, a sound or concussion happens in front of the membrane *a* in the transmitter, it will produce upon the membrane and its armature *c*, an inward motion toward the magnet *b*, to be followed by an outward motion away from it. These motions

## Argument of counsel.

of the inductive armature, by a well-known law of what is called magnetic induction, produce new and artificial currents in the coil of the electro-magnet, which add themselves to the current there flowing, causing it to be of a lesser or greater strength according to the movement of the armature to and from the magnet, and to the violence of such movement. Thus, if the normally constant strength of the current from the battery be taken at a unit of 100, one movement of the armature will set up an extra current, which, being added, or as the technical phrase is, superposed, upon the constant battery current, will cause it to be 99; and again upon the opposite movement of the armature will increase it through various degrees to 101.

The increase and reduction, according to these well-known laws, will be in exact proportion to the violence and extent of the armature movement. These changes in the intensity of the battery current are also called undulations; and doubtless for the same reason, viz.; that the customary graphical representation of them will show a wavy line, as will also any graphic chart of rise and fall in the price of wheat. The constant battery current as will be perceived is not the efficient cause of work, and has theoretically no part in that work. Its sole function is to keep the soft-iron core magnetic. This is proved by *withdrawing the battery altogether and substituting permanent steel magnets* in place of the soft-iron electro-magnets, when *no difference will be found*; from which it is apparent that whereas, in the variable resistance method the battery is essential and the induction-coil (used only where a secondary circuit is desired) non-essential, in the magneto method the battery is non-essential and a coil is essential—for transmission.

In Bell's invention, the novelty consisted in the use of the energy of the air-waves to mechanically actuate a dynamo machine, and to cause it, not to mould,—as is sometimes claimed—but to create the electrical currents which are to do the work.

## Argument of counsel.

The essential characteristic which distinguishes this method is: *A magnetic field disturbed by the shifting presence of an inducing body ; which thereby creates electrical undulations in the wire.* The efficient, is the magnetic force ; its source is the magnetic field ; and the battery current is not in any sense the cause of work.

In the variable resistance method, the operative current has its source in a battery, and flows thence with a constant energy and direction ; and the needed changes in it are caused by a variation of the resistance to its flow.

This is known in the arts as the "loose contact," "variable contact" or "variable resistance" method. In every apparatus ever devised to work by this method—beginning with that of Reis in 1861—the necessity to keep the contact loose introduces a possibility that it will be *broken* by *too great loudness* in the tones which are sought to be transmitted. In fact, the Blake transmitter frequently breaks contact in this way, and for this cause. The circuit of which a loose contact of electrodes is a part can never be spoken of as a "closed circuit" (within the sense of this patent which shows only closed circuits, incapable of being ever open), any more than any Morse circuit, which, like the former, may sometimes be open and sometimes closed.

In the magneto method the battery current is not effective for reproducing speech, its sole function being, as above stated, to render the soft-iron core magnetic. If for that a steel core, permanently magnetic, be substituted, the battery may be abandoned altogether.

In this, the magneto method, the circuit was properly designated by Mr. Bell in his patent as a "closed circuit"—because there is *no possibility of opening it.*

The terms "continuous current" and "closed circuit," when used in the patent, or in any remark with reference to Mr. Bell's claims, are to be construed in harmony with, and in subordination to, his drawings and delineations, *i. e.*, as being, by reasons of the mechanical structure and connections

## Argument of counsel.

shown, incapable of being other than "closed" or "continuous."

No circuit which is capable of being either open or closed, according as accident or design may determine, is the "closed circuit" of the patent; and no current flowing in a circuit where it may be continuous or discontinuous, as accident or design may determine, is the "continuous current" of the patent.

These two ways of producing current changes by the energy of sound-waves are two different methods in the arts and in the law.

*A patent for the last is not infringed by the practice of the first method.*

The judgment of the circuit sustains the allegations of infringement under the 5th claim, and no other claims of the patent of 1876; and the opinion of the Court shows that it is the so-called "method" portion of the 5th claim which is deemed to have been infringed.

The apparatus portion could not be considered infringed, since the two (transmitter) machines are essentially different, neither being capable of use in the place of the other. The one is adapted to vary the forces of a current flowing through it by interposing opposition to its flow. The other is adapted to the introduction in the current flowing, not through it, but in its neighborhood.

As to the parts of Bell's device, the limits of novelty will be seen when we know that Reis used the mouthpiece membrane (Reis-Bourseul Pub. p. 33); Pickering (Overland Rec. p. 208), and Bourseul, the metallic diaphragm; Schellen, the permanent magnet with the coil on the end encircling an electro-magnet exactly as figured in the Bell patent of 1877 (Mol. Rec. p. 748); Reis-Legat, the electro-magnet (Reis-Bourseul Pub. p. 29); and Wright, the induction-coil (Ferguson, Electricity, p. 258).

Bell's patented methods are, first, a method for producing

## Argument of counsel.

electrical undulations in a closed magneto circuit, as set forth in his claim 3.

The second is a method for producing electrical undulations in variable resistance circuits, as set forth in his claim 4.

The third is for transmitting sounds telegraphically, as set forth in his claim 5.

The 3d and 5th claims are illustrated by an apparatus, Fig. 7, which, long after the date of the patent, is said to have proved operative, though it has never been in use.

This is an apparatus for *transmitting* sounds by the method of causing undulations in the magneto method.

No apparatus for *transmitting*, etc., by causing undulations in the variable resistance method is shown, or even hinted at, in the patent.

A way of creating undulations in a voltaic current, through a circuit capable of being open or closed, is stated.

But how—that is, by what method or apparatus—these undulations can be put into a form similar to any sound, or can be used in vocal or other sound transmission, we are not told.

Further invention was required for this. Such invention had been previously made by Elisha Gray, and a caveat therefor filed in the Patent Office previous to the granting of Mr. Bell's patent.

If the device was Bell's invention, it was either made before the granting of the patent, and was therefore abandoned, by not being described; or was made after, and therefore cannot sustain a previous broad claim for a process.

Fig. 7 is incapable of application as an alternate or substitute for the liquid, or any other variable resistance transmitter. Fig. 7, or its equivalents, cannot therefore be relied upon to satisfy the requirement of the law, that a patent for a process must contain a description of some apparatus by which the process can be applied with beneficial result.

Tilghman v. Proctor, 102 U. S. 729 [13 Am. & Eng. 29].



# Legat Reproduction von Tönen auf elektro galvanischem Wege.

## Tafel VIII.

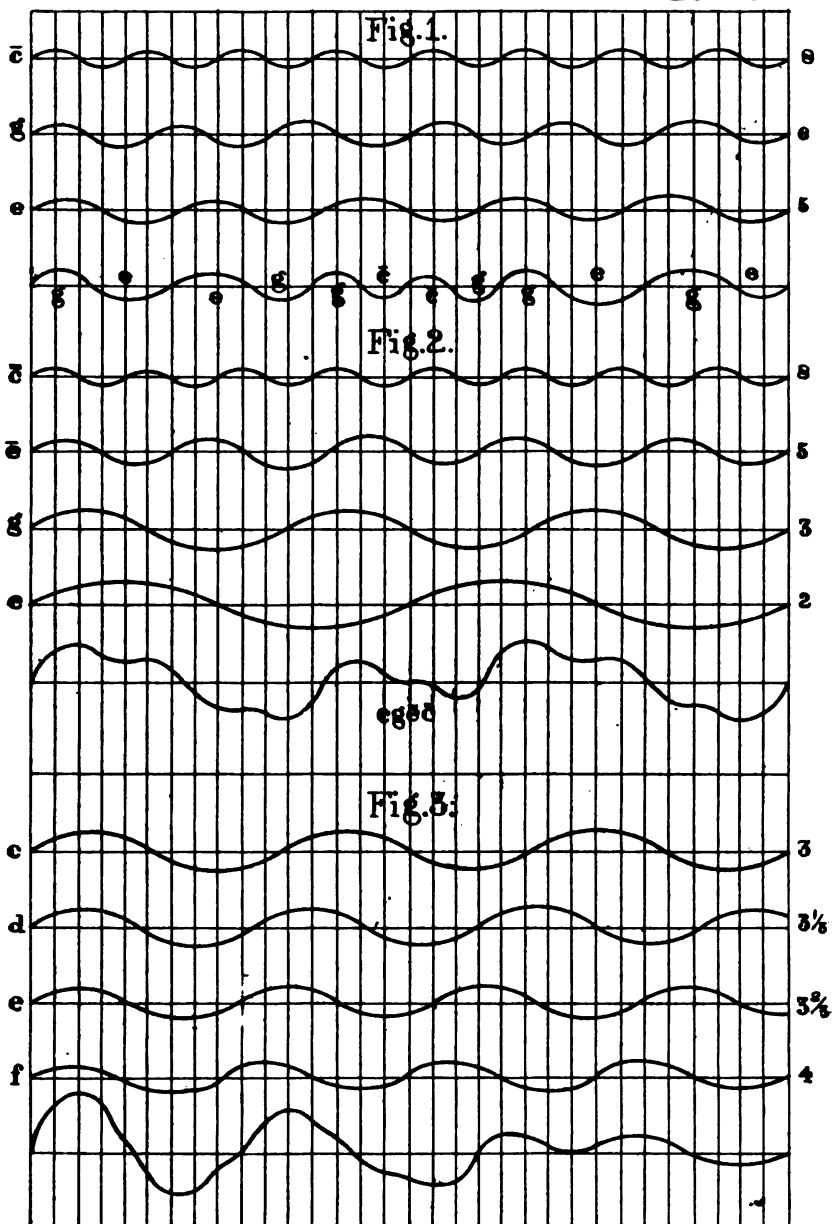

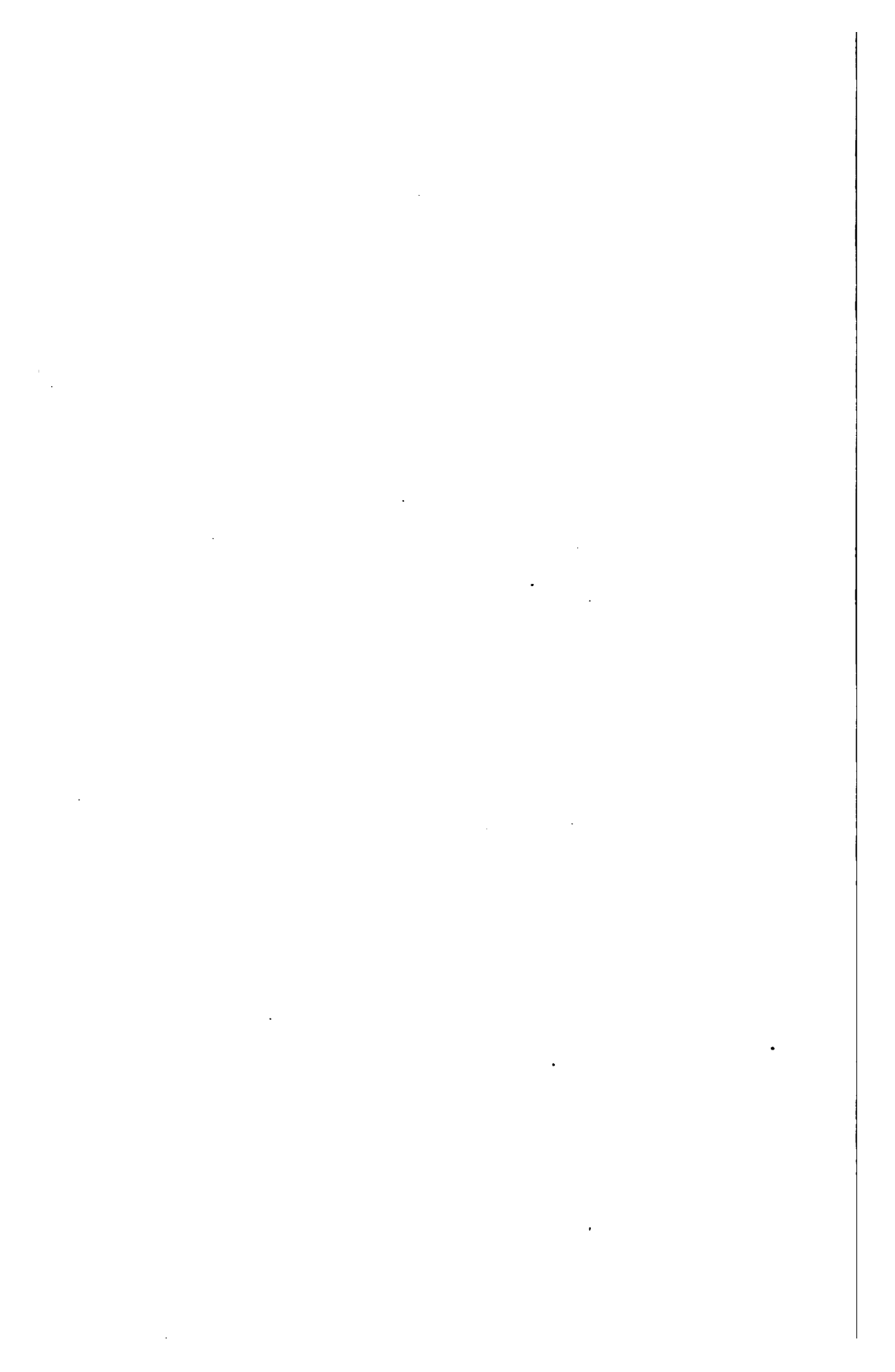

## Argument of counsel.

The contention of the complainants begins with a confounding of patented methods, and results in monopolizing a law of nature.

Sound, considered in the physical sense, is a particular vibratory motion in ordinary matter.

When sound comes to be appreciated *physiologically*, the ear recognizes in it a variety of things.

First, it recognizes pitch; the sounds may be high or low. Second, the sounds may be loud or soft. Third, they may be of an infinite variety. These differences arise from differences in (1) the extent, (2) the number, (3) the character of vibrations made by the air particle in obedience to the sound-producing cause; that is, whether they be of pendular or irregular form.

The *pitch* of the sound will depend solely upon the number of vibrations which the air particle makes to and fro in a given time.

The *loudness* or *intensity* of the sound will be determined by the extent (called amplitude) of the vibration.

*Quality*, or *timbre*, is the third effect by which the ear perceives the difference between different sounding bodies. This sensation is hypothetically imputed by physicists to the manner in which the compounded vibrations have been performed.

*Reis curves of three and four tones sounded simultaneously, and the combination or resultant curve in each case.*

Helmholtz, *Sensations of Tone*, second English edition, by Alex. J. Ellis, London, 1885, p. 19, says:

“On inquiring to what external physical difference in the waves of sound the different qualities of tone correspond, we must remember that the amplitude of the vibration determines the force or loudness, and the period of vibration, the pitch. Quality of tone can, therefore, depend upon neither of these.

“The only possible hypothesis, therefore, is that the quality of tone should depend upon the manner in which the

## Argument of counsel.

motion is performed within the period of each single vibration."

Upon this hypothesis rests, therefore, the assumption at present universally made and accepted in the scientific world for purposes of scientific reasoning, that the quality or *timbre* of sound, or that which enables distinction between different sound-producing causes to be recognized by the ear, arises from, is dependent upon, and truly represents, certain assumed or postulated eccentricities of conduct by the air particle while engaged in performing a certain number of journeys, of a certain length, within a certain time. Upon this Mr. Bell forms a similar *hypothesis* as to electrical action, and draws a conclusion that the electrical current undulates. And this conclusion—built up, hypothesis upon hypothesis—he has patented.

When more than one simultaneous tone or sound acts upon an air particle it produces a compromise in the vibration. This is called a resultant vibration, and is the algebraical equivalent of all the others. Mathematicians represent it, as well as the movement of the vibrations which compose it, by curves.

*Quality* is that peculiarity in sound which allows us to distinguish between sounds of the same pitch and the same intensity. Thus the sound produced by the flute and clarinet are at once distinguishable.

A simple sound is one which generates an air particle motion of strictly pendular vibration.

The following is a graphical representation of the vibration due to a simple sound :

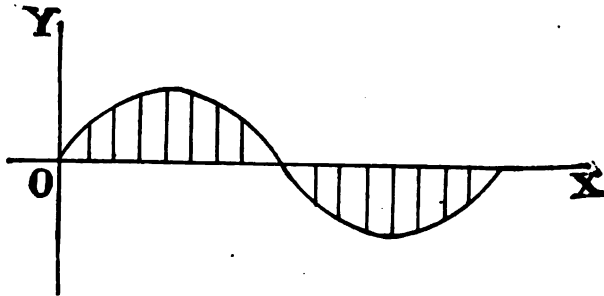

## Argument of counsel.

Whenever a sound is composed of more than one tone it begins to have *quality*. The expression of that quality is in the form.

## COMPOUND TONES.

When several fundamental tones with their related harmonics are simultaneously sounded, we have what is called a "chord" in music. The increased complexity resulting from such simultaneously sounding tones makes the quality of the compound sound more marked than the quality of any simple fundamental tone.

The following plate of curves, known as Mayer's Harmonic Curves, represent at *a b* the separate curves of six simple sound-waves, being the sound-waves of a fundamental and its overtones. The motion which an air particle will

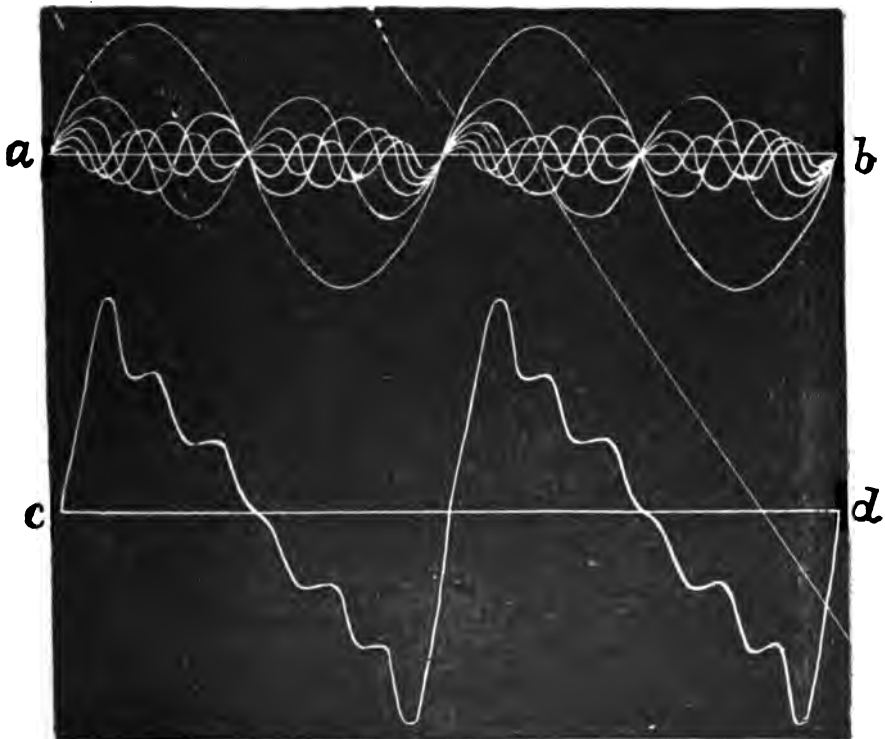

## Argument of counsel.

actually take up under these differing influences is represented by what is called the "resultant curve," shown in the same plate at *c d*.

The most complex and variable of all sounds is that of articulate speech. Articulate speech is a combination of vowels and consonants following each other in a certain order or system prescribed by the law of language.

Speech consists, in the first place, of the emission of sounds having different characters, peculiar timbre, to wit, vowels. The second element of human speech consists of consonants, which are not persistent tones, but modes of beginning or finishing the vowel tones by a sort of explosion; that is, by a movement of the air comprising at the most a very small number of vibrations, of different form from those of the vowels which they modify. When a consonant begins a word, such explosion precedes the musical sound of the vowel and ceases as soon as the vowel sound has taken place, as in *ba, be, bi, etc.*; or, it terminates the vowel sound by a final motion of the lips, as in *ab, at, ar, etc.* The consonants in no way depend upon or are affected by the pitch of the vowel sound which they introduce and terminate.

The method by which each kind of sound will be transmitted *telegraphically*, will be "causing electrical" variations, oscillations or "undulations, similar in form to the vibrations of the air accompanying the sounds."

The curves due to certain articulate sound vibrations are shown by the well-known "Brown-University Curve" of Professor Blake.

Any variable resistance instrument, in transmitting telegraphically a simple sound composed of a fundamental and its overtones, or, simultaneous musical tones with their respective overtones, will necessarily operate by the same process or method as the same or another instrument, when transmitting telegraphically the higher complexities of human speech. This method will necessarily be that which has been patented by Mr. Bell under the terms "by causing elec-

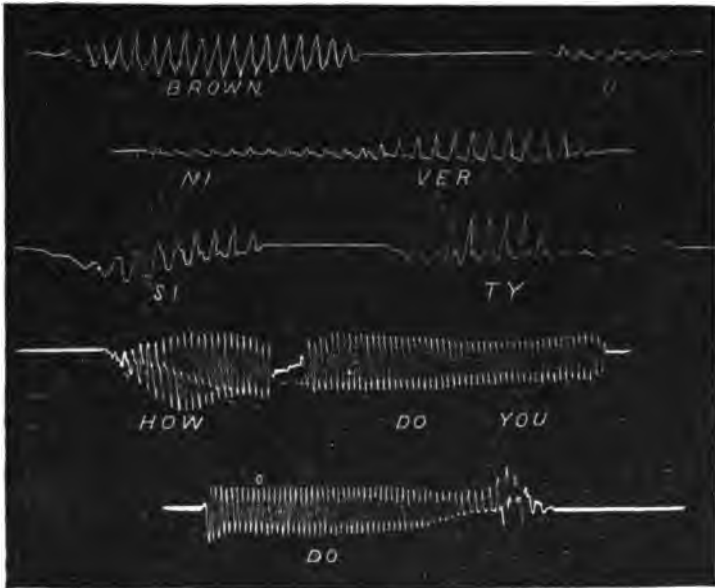

The citations above, and the references to Reis instruments, have been made at this place in advance of any description of those instruments, in order to sustain the general proposition, which is now made: .

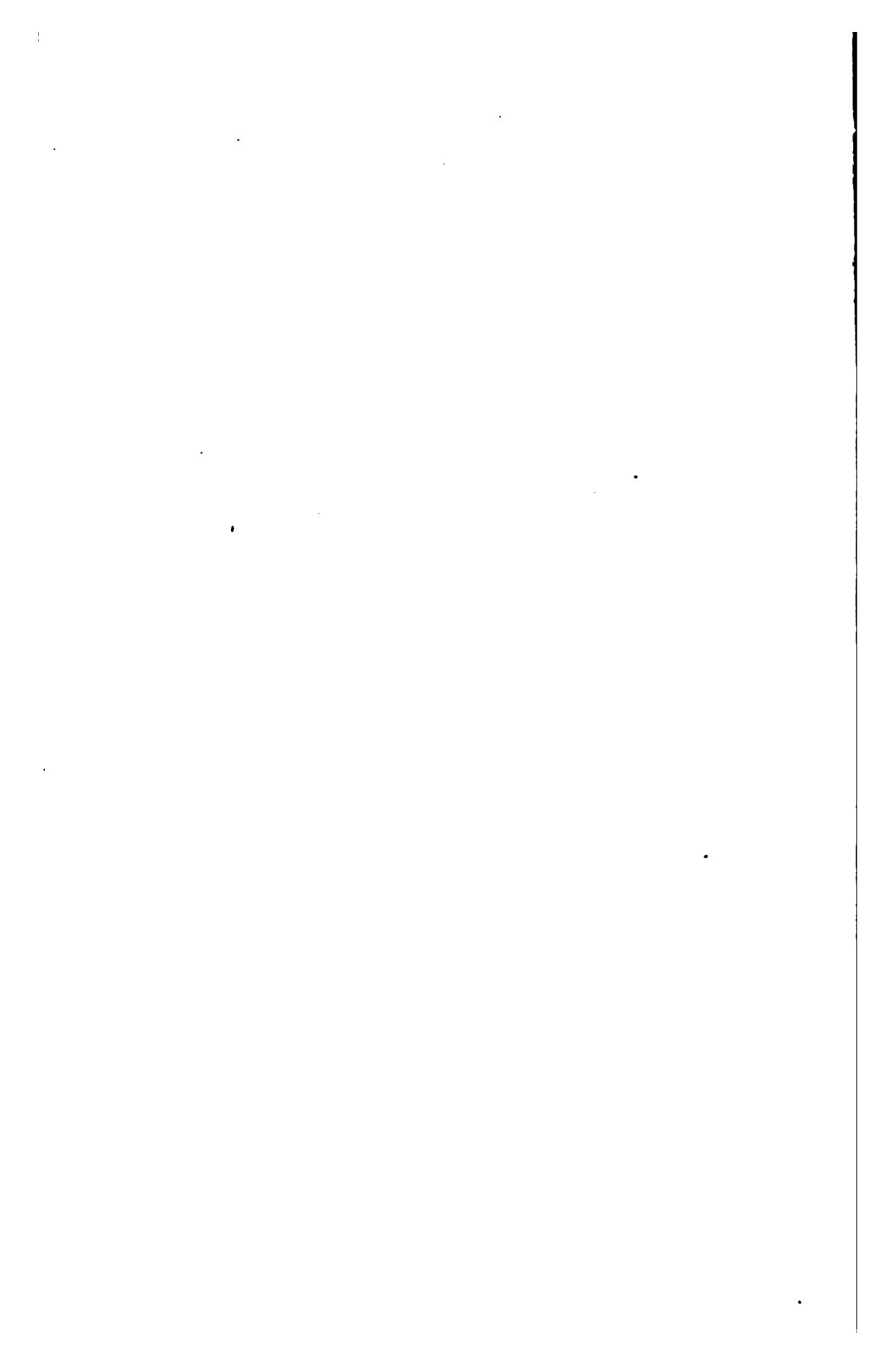



## Argument of counsel.

trical undulations similar in form to the vibrations of the air accompanying the sounds," whether the hypothesis expressed and patented in those terms be correct or not. Between these different uses and the operations required to accomplish each, will be found no new law, and no new art, but only degrees of mechanical adaptation or development in apparatus.

Reis and Bourseul possessed knowledge that the transmission or reproduction of any sound, simple or compound, *in or through any of the media to which nature has given capacity to transmit sound vibrations*, must be by means of vibrations similar in amplitude, rate and form to the vibrations immediately accompanying the sound; and this, too, whether the vibrations be to-and-fro motions of matter, or plus (+) and minus (—) *changes in the strength of an electric current*; and whether the energy of the air-waves themselves is the actuating cause (thus in a sense propagating itself), or is imitated by some other mechanical action.

The knowledge of this law is claimed to have been given to the world by Mr. Bell; and that erroneous idea is the sole foundation for the broad patent claim under which the rest of the world has heretofore been excluded from practicing an art, all the principles and conditions of which were known and published to the world before the year 1864, and the complete commercial realization of which awaited only a good mechanic to make a suitable apparatus, and a Boston syndicate to give it a favorable introduction to the world.

In 1854-64, the state of knowledge in acoustics, electricity and magnetism included certain fundamental laws.

## IN ACOUSTICS.

1. That sounds are propagated by vibrations of matter.
2. That the loudness of any sound is determined by the amplitude of the vibration, or the distance through which the air particle moves to and fro.
3. That the pitch of a sound is determined by the number

## Argument of counsel.

of times in which an air particle will traverse this amplitude in a given time.

4. That simple sounds give simple periodic and regular vibrations.

5. That all sounds are compound whose vibrations are the result of simultaneous action of several simple tones, whether resulting from one or from a number of sounding bodies.

6. That "quality" pertains to and is predicable of all compound sounds—of which articulate speech is one class; and that the air particle, in obeying the impulses of the compound-sound-producing causes, no longer makes the motion due to any one of them, but another motion, which is a compromise upon, and the algebraic sum of all their varying and perhaps conflicting impulses.

7. That quality is expressed and represented by something in the manner in which the vibration is made, different from the amplitude and rate, but included within the amplitude.

8. That air vibrations can be taken up and reproduced by a plate or diaphragm.

## IN ELECTRICITY AND MAGNETISM.

As will appear by the references to the writings of Bourseul and Reis, it was also known before 1864, and substantially published to the world:

9. That plate or membrane vibrations, derived from air vibrations can be made to produce in a conductor electrical changes corresponding to the air vibrations.

10. That by the use of an electro-magnet and a second plate, the electrical vibration can produce another air vibration in another place corresponding to that which accompanied the original sound; or, in other words, that vocal and other sounds can be transmitted "telegraphically, by causing electrical undulations similar in form to the vibrations of the air accompanying the sounds." (Bell's 5th claim.)

## Argument of counsel.

11. That apparatus capable to perform this work was devised, publicly used, and descriptions thereof, sufficient in law to establish an anticipation, were made prior to the year 1874, when Bell claims to have conceived the idea of his magneto telephone.

With these observations upon the state of knowledge and the arts before 1861, we may next give attention to,

First, conception of the art of transmitting speech by electricity.

The first published conception of any plan by which speech might be transmitted over an electric conductor and reproduced occurs in "*L'Illustration Journal Universel*," Paris, 1854, in a communication by Charles Bourseul, in which he says:

"I have asked myself, for example, if the spoken word itself could not be transmitted by electricity; in a word, if what was spoken in Vienna may not be heard in Paris? The thing is practicable in this way:

"We know that the sounds are made by vibrations, and are made sensible to the ear by the same vibrations, which are reproduced by the intervening medium." \* \* \*

"Syllables can only reproduce upon the sense of hearing the vibrations of the *intervening medium*. Reproduce precisely these vibrations, and you will reproduce precisely these syllables. \* \* \* I have made some experiments in this direction. They are delicate and demand time and patience, but the approximations obtained promise a favorable result."

In this paper, unprecedented by publication in any scientific or other work, or by any discovery or suggestion, Charles Bourseul suggested not only an apparatus applicable for the conveyance of sounds, but a principle of operation which constitutes a necessary condition of the telegraphic transmission of speech.

Both he and, afterwards, Bell had in view the reproduction, by means of the electric current, of the vibrations which cause the sensation of sound.

## Argument of counsel.

The following is an ideal suggestion of Bourseul's plan without working parts:

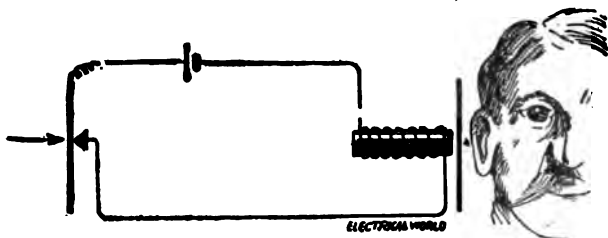

Bourseul had expressly in view the reproduction of such specific sounds as constituted articulate speech. He declared that spoken syllables could have their due and desired effect, only when the vibrations of the entire intervening media were substantially like the vibrations accompanying the spoken syllable.

The subject under discussion was the doing this with an electric current and wire. That a transmutation of mechanical into electrical forms of action and back again would happen, was, therefore, a fundamental condition of every argument and statement.

In other words, it was recognized and announced as a law, that the syllables could not produce their effect unless their vibrations were *reproduced* throughout *all* the intervening media, including, of course, the electrical conductor and current.

The telephone of to-day could not be better described than, in the terms of Bourseul, *as an instrument by means of which spoken syllables can reproduce, through correspondent vibrations of various intervening media, a distant effect upon the sense of hearing, equivalent to themselves.*

It is of no practical or legal consequence that Reis was mistaken in his *theory* of the operation of his apparatus. It is sufficient that he gave such description thereof as would enable one skilled in the art to accomplish the result pointed out—that of transmitting speech.

## Argument of counsel.

Treadwell *v.* Parrot, 3 Fish. Pat. Cas. 124; Hamilton *v.* Ives, 6 Fish. Pat. Cas. 244, 253; *S. C.* 92 U. S. 426 [10 Am. & Eng. 405].

In 1861 Reis says: "With the above principles as a foundation, I have succeeded in constructing an apparatus with which I am enabled to reproduce the sounds of various instruments, and even to a certain degree the human voice."

Reis and Bourseul Publications, p. 15.

Reis's telephone was sufficiently operative, according to the statement in the Legat and Reis papers, and the proofs in the case, to have sustained a patent, and to anticipate a subsequent invention.

Pickering *v.* McCullough, 104 U. S. 319 [13 Am. & Eng. 238]. Woodman *v.* Stimpson, 3 Fish. Pat. Cas. 98.

If Reis and Legat, with Bourseul, had in 1864 applied for a United States patent with broad claims for the art of transmitting vocal and other sounds telegraphically by electricity, in the manner and with the apparatus shown in the Reis-Legat paper, can it be doubted that they would have obtained it? Or that Bell, coming after them, would have obtained more than a patent *limited* to his magneto apparatus and method?

Had they taken out such a broad patent for the discovery of the "art" of "transmitting," etc., "vocal and other sounds," can it be supposed that any errors of opinion as to the automatic or natural function of the machine would have impaired the validity of the patent?

Saint Louis Stamping Co. *v.* Quinby, 4 Ban. & Ard. 192.

The microphone consists, physically, of two electrodes placed normally in contact, with a slight pressure, and forming part of a circuit supplied with a current from a battery. The principle of the microphone is the principle of a loose joint.

The following outline of the operative parts of the principal variable resistance transmitters may be referred to:

The modern receiver, by its perfection, likewise reveals

## Argument of counsel.

the perfection of the ancient Reis transmitter. That transmitter crossed with a good receiver always produces speech.

The microphone transmitter originated in two places: in Germany, at the hands of Reis, and in England, at the hands of Professor Hughes.

We have here pictures of the Reis-Legat instruments.

1. The tone transmitter consists of a conical tube, about fifteen centimetres in length, having a front opening of about ten centimetres, and a rear opening of about four centimetres.

2. The narrow end of the conical tube is covered with a collodion membrane.

3. A curved lever *c d* is suspended in such a way, that one end of the lever rests on the collodion membrane, and the other rests against the spring *g*, and is to be "*kept in electrical connection*" with the metallic conductor.

4. The proper lengths of the respective arms of the lever *c e* and *e d* are not given, but it is said that they are to be regulated by the laws of the lever.

5. The object to be attained is named. It is "in order that the least motion at *c*" (the membrane) "may operate with greatest effect at *d*" (contact-point).

6. "It is also desirable that the lever itself be made as light as possible *that it may follow* the movements of the membrane." "Any inaccuracy in the operation of the lever *c d* in this respect, will produce false tones at the receiving station."

7. When in a state of rest, the contact at *d g* is closed, and a delicate spring *n* maintains the lever in this position. With slight changes in construction, the Reis-Legat instruments will successfully transmit speech.

The proofs concerning the Reis instruments may be summed up as follows:

1. Any instrument capable to transmit tones having quality, is theoretically capable to transmit articulate speech.

2. The Reis instruments are capable to transmit tones having quality; to wit, musical tones of the voice, tones of

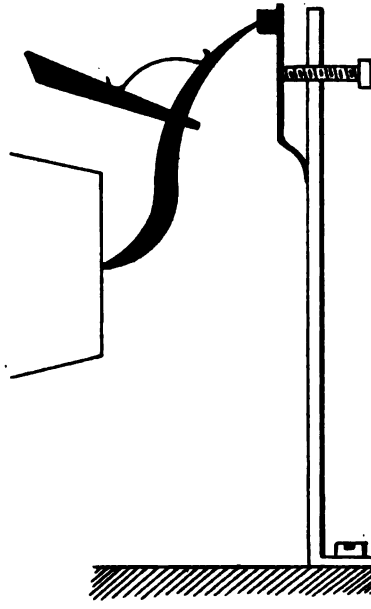

*Reis-Legat Transmitter.*

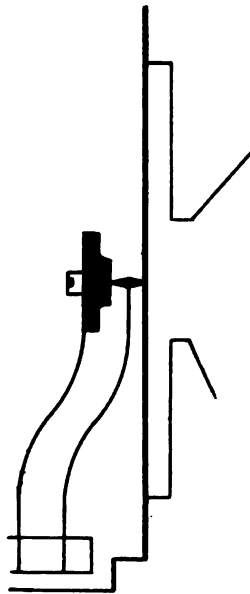

*Blake Transmitter.*

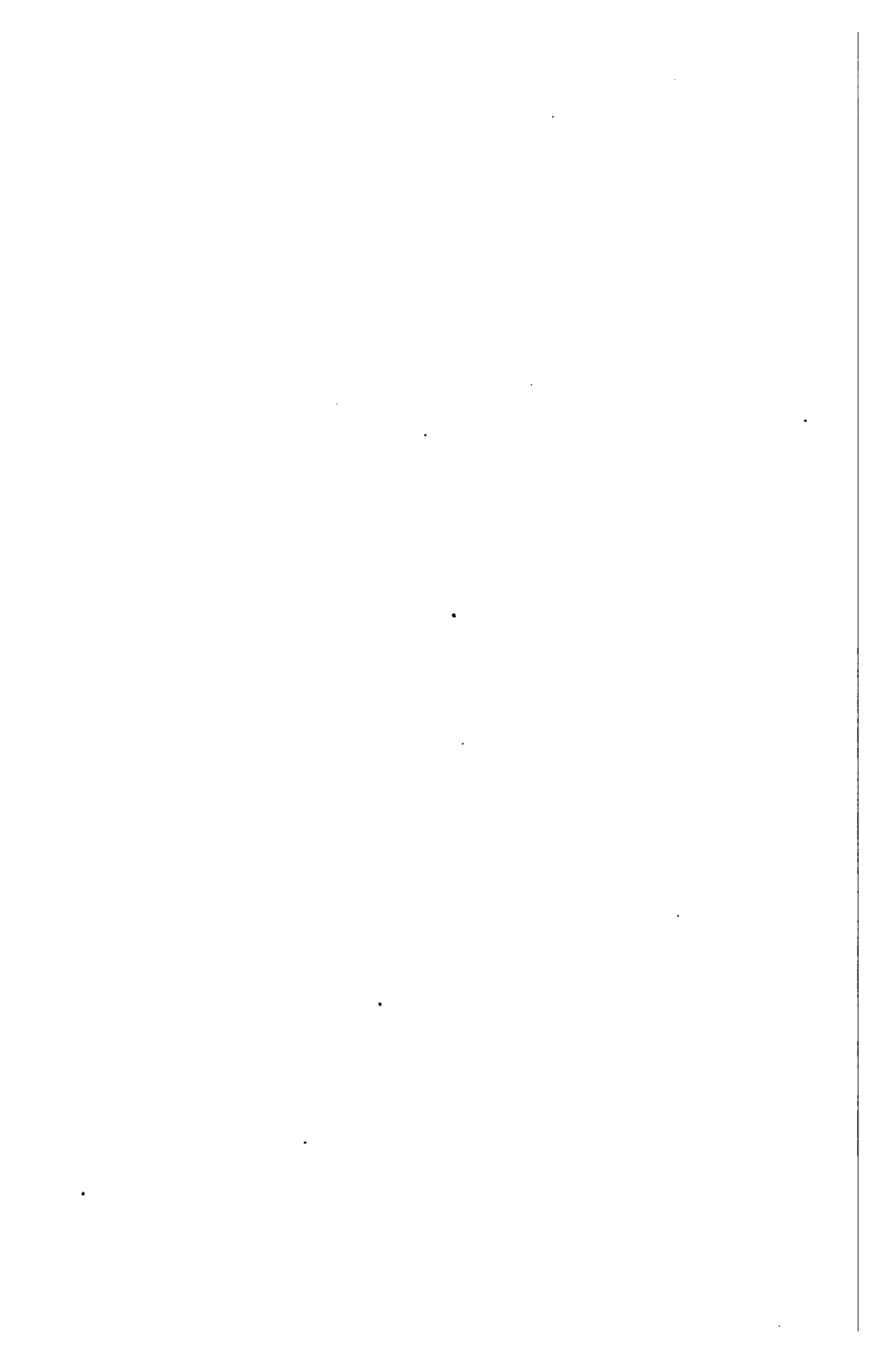



**v. Legat, Reproduction von Tönen auf elektro-galvanischem Wege.**

*Fig. 14.*

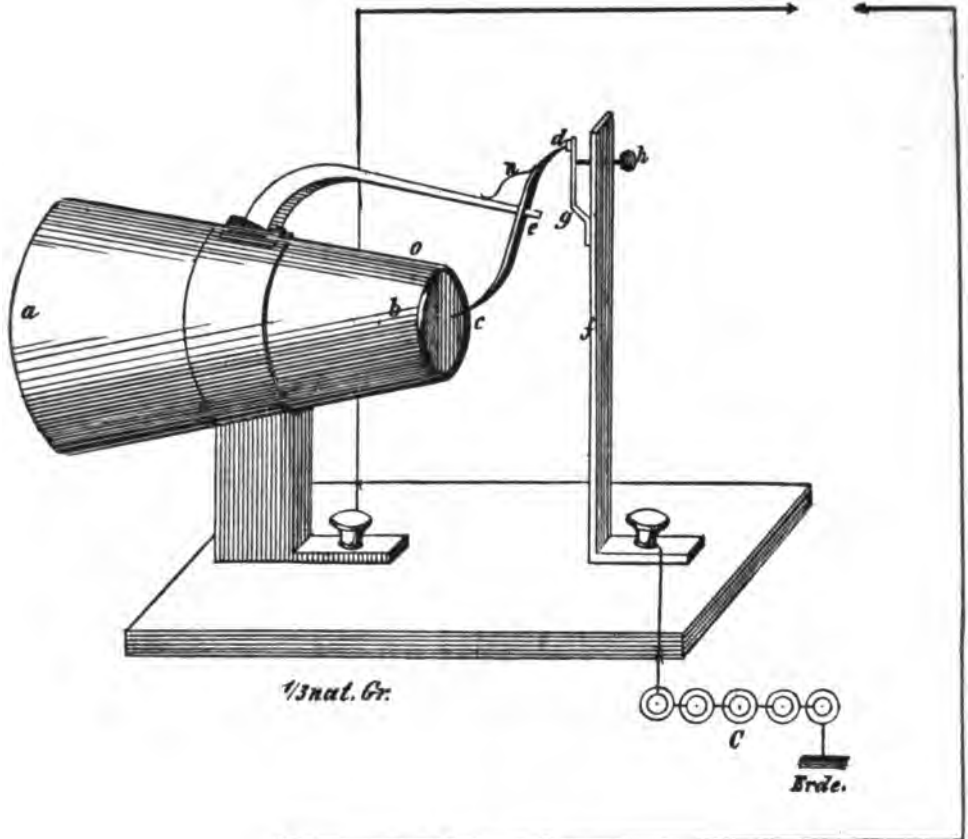

*Fig. 15.*

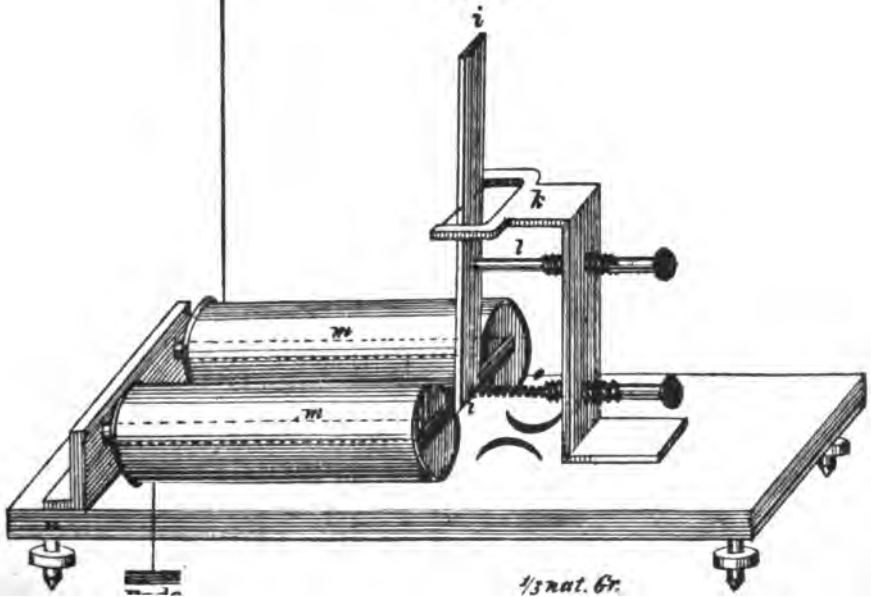

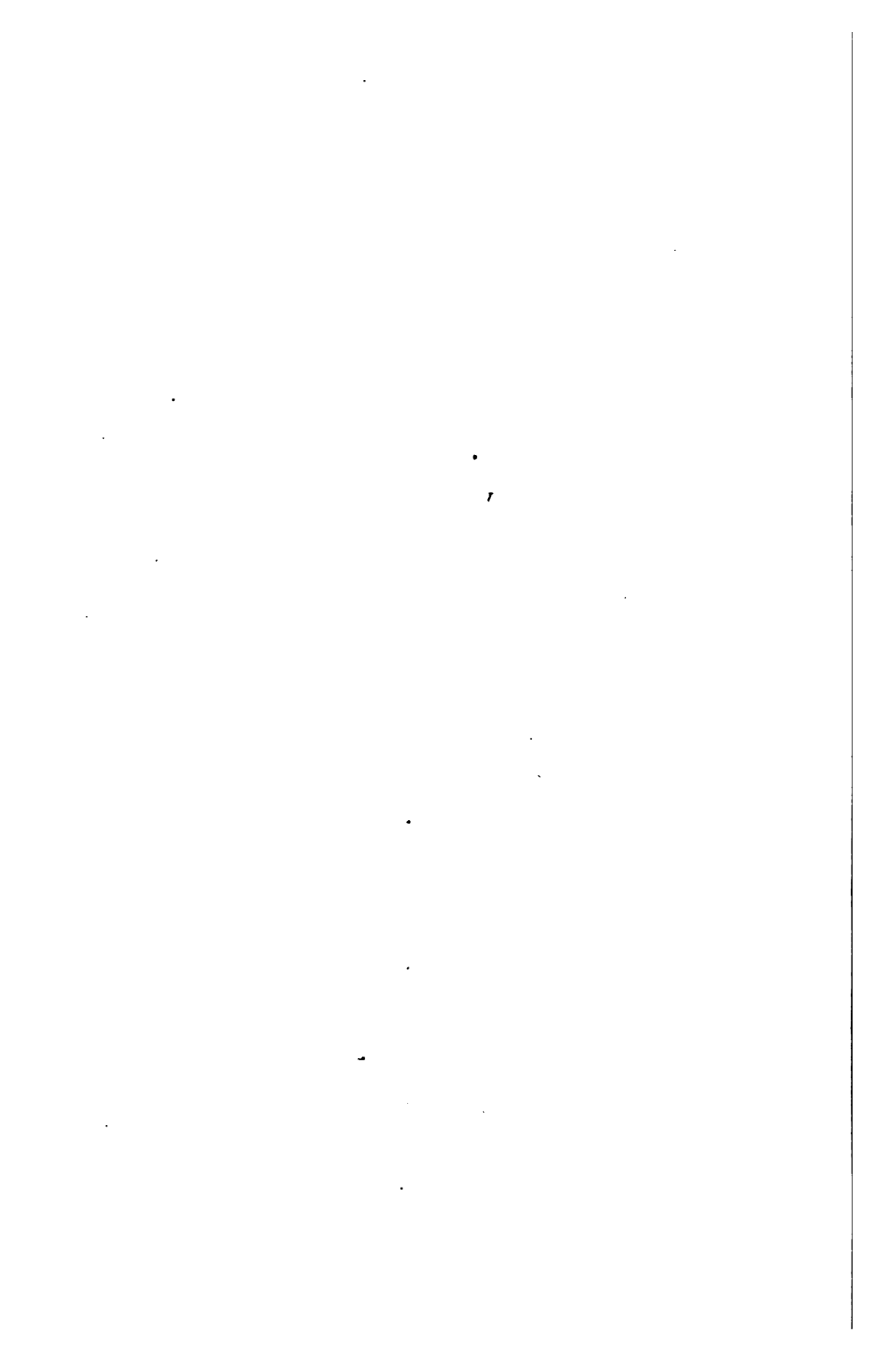

## Argument of counsel.

various musical instruments, and chords consisting of two or more simultaneously sounded notes.

3. The Reis instruments were devised for the transmission of articulate speech.

4. The Reis instruments did transmit words and sentences in the hands of Reis and of others in his time.

5. The Reis instruments will now, using his transmitter and receiver together, "talk," though with uncertainty.

6. The Reis transmitter will transmit clearly and well, when united to a good receiver, such as the McDonough, or Bell magneto receiver.

7. The Reis apparatus entire will "talk" well, when modified in mechanical construction, without the addition of any element not already there.

8. Whenever and wherever the Reis instrument has talked, or can be made to talk, it avails of a natural method being the same which Mr. Bell has, under a name and description, the fitness of which appears as yet incapable of verification, claimed and patented.

Upon this state of facts, concerning the art of transmitting speech, before 1874, it becomes material to inquire: When is an art discovered?

To conceive that a new thing can be done; to indicate in a correct, though general way, the laws of nature which must be availed of; to create suitable apparatus—although suitable only in a limited degree; to use the apparatus, and succeed in the avowed purpose—though only in a limited degree; to publish the result with sufficient specification to reveal the whole purpose, and put the world fairly upon further inquiry,—appears to take the doing of that special thing out of the category of the undiscovered arts.

From that stage, in the development of that art, it would seem that invention and discovery must be deemed limited (by the state of the art) to the improvement and perfecting of old, or the invention of new modes and mechanism.

This difference between the discovery of an art, and the

## Argument of counsel.

perfected practice thereof, is what the Court is called on in this case to clearly distinguish.

Bourseul had, in 1854, by pure force of reason, predicated the capacity of electricity to transmit speech; had formulated a general expression of the law of such transmission, which is now found to include and be harmonious with all the particulars of our present state of knowledge; and had suggested an apparatus.

Reis had in 1861 pursued the law of acoustical action and effects to a fuller extent; had made an electrical machine; had challenged and solicited nature to act within the electrical and hidden part of the operation (according to her own laws whatever they might be); had received a favorable, though grudging and capricious response; and had published to the world that: "With the above principles as a foundation, I have succeeded in constructing an apparatus with which I am enabled to reproduce the tones of various instruments, and even to a certain extent the human voice."

*From this time it was not open to Mr. Bell to discover speech transmission as a new art.*

The 5th claim is a claim for the electrical transmission of speech under the form of a description of how nature does it.

This may be likened to a claim for raising wheat by the germination of the seed of the plant, leaving mankind free to produce wheat by all other methods.

In fact, what Mr. Bell has discovered is, not that electrical undulations *can*, but that they *do*, transmit sounds by conforming themselves to the characteristics of the energy which creates the sound, and that they will do this in no other way. This is a scientific fact.

*Thus considered he has been able to monopolize a natural force and patent a scientific fact.*

Considering that the process rests upon the existence of electrical undulations which are similar in form, etc., it is now and without argument, at this place, submitted that no one of the famous process cases has decided anything which

## Argument of counsel.

will justify a patent upon a process or condition, the existence of which is incapable of proof.

That speech cannot be transmitted when the current is not continuous is not proved.

That undulations in continuous electric currents occur when speech is transmitted is also not proved.

Proof thus qualified and doubted is not adequate to support a judicial judgment (affecting important property rights), that the electric current used in a microphonic telephone transmitter is either continuous or undulatory.

Previous to 1867 Doctor Horace S. Wright, of Edinburgh, Scotland, used an induction-coil as an adjunct to a sound-transmitting apparatus in connection with a Reis transmitter.

A Wright condenser will transform electrical variations, or undulations, similar in form to the sound-waves, into corresponding sonorous vibrations, and thereby produce sounds and articulate speech.

Dr. Van der Weyde at an early date constructed a number of instruments, which he exhibited at a meeting of the Polytechnic Club of the American Institute, in Cooper Union, January 7, 1869. On that occasion the experiments were confined to the reproduction of the human voice.

Thus we have the modern microphone in *actual use* in this country, according to the modern method, long prior to the Bell patent and to any pretense of Bell's invention or conception.

On the 8th day of April, 1870, British letters patent were granted to Varley. The Varley condenser, *constructed as in Mr. Varley's patent, is capable of reproducing speech.*

His undulations are just what Bell's are, since they *will transmit speech.*

There is no substantial difference between an undulatory current, such as produced by the apparatus of Mr. Varley, and an undulatory current created or generated by an apparatus constructed in accordance with Fig. 7 of said Bell patent.

## Argument of counsel.

The art of creating such undulations is one generic art; which in its specific branches demands no new principle, but only greater mechanical adaptation.

The instruments constructed by Mr. James W. McDonough and used by him *in the year 1875, for the transmission and reproduction of articulate speech, contained all the vital and essential elements of the telephonic apparatus now in commercial use.*

Prior to Bell, McDonough constructed *an apparatus capable of transmitting and reproducing articulate speech*, and set forth in his application for letters patent, that that was the object of his invention.

In the winter of 1866 and 1867, Elisha Gray constructed an instrument for transmitting tones. Apparatus shown and described in British letters patent, No. 2646, dated July 29, 1874.

The apparatus shown in Fig. 4 of Gray's British patent contains a common or universal receiver capable of responding to all kinds of tones, and *consequently of reproducing articulate speech. This receiver is essentially a Magneto Telephone.*

Gray's American patents 166,095 and 166,096, dated July 27, 1875, described a method of producing *electrical vibrations in a closed circuit and reproducing them upon a common or universal receiver.*

Professor Geo. F. Barker, an eminent physician, says: "Gray, therefore, seems to have been *the first to formulate distinctly the conditions necessary to transmit the form of the sound-wave electrically through a wire, and to devise a practical manner of accomplishing it.*"

Gray's invention anticipated Bell's first patent. Bell's patent is for a multiple telegraph or for a singing telegraph or telephone for multiple telegraph.

If, however, it can be claimed that the first patent is a patent for anything beyond the multiple telegraph, we submit that it cannot be construed as a patent for anything but

## Argument of counsel.

a magneto-electric telephone, and that the "*method*" of the 5th claim is the method of a magneto-electric telephone.

If the claim is given the broad construction asked for it by the complainant, it would be void, as a patent for a theory.

There is another aspect of this patent, pursuant to which we submit it must be held void as a patent for the new art or process of transmitting speech. That art or process is not described in the patent.

In *Wakeman v. Corcoran*, L. R. 13 Ch. Div. 65, the familiar rule of law is stated that "the specification of a patent is bad if a skilled mechanic would not, without performing a series of experiments, be able to construct the machine from the description." And on page 72, Justice Fry says: "The patentee must state not merely the problem which is to be solved, but the mode of solving it."

*Tyler v. Boston*, 7 Wall. 327 [8 Am. & Eng. 1]; *Wood v. Underhill*, 5 How. 1 [4 Am. & Eng. 551].

In the case of *Downton v. Yaeger Milling Co.*, 1 McCrary, 30, 31, *affd.* 108 U. S. 466 [14 Am. & Eng. 513], the Court says:

"On the other hand, irrespective of the question of estoppel, if the patent is for a process to be effected without any known means of accomplishing the result, but requiring inventive faculty, whereby rolls to accomplish the purposes and their modes of operation were to be determined by new inventions or discoveries, then the patent does not furnish to any one, as then skilled in the art, means whereby the beneficial end could be accomplished. No one in the then existing state of the art could, by the use of any rolls known, or by any modes of operating the same, have effected the designed end; consequently, to uphold this patent for a process, which would have been ineffective without some inventions thereafter had, would be to block the path to all future progress in the art of milling."

Defendant's instrument is called a microphone, an invention of the highest character. Professor Bell, in the *Preece*

## Argument of counsel.

discussion, says: "No one can more heartily congratulate Professor Hughes upon his *great discovery* that I do." This Court regarded discovery as the basis of and antedating a process.

Corning *v.* Burden, 15 How. 252 [6 Am. & Eng. 69].

The decree is also erroneous in that it finds that the defendant infringed the 6th, 7th and 8th claims of patent No. 186,787. That patent is not for an invention. It is not for a combination.

We submit that, in view of the state of the art, Bell's patent, No. 174,465, must be limited, either—

1. As a patent for a multiple telegraph, or a musical telephone, or,

2. As a patent for the magneto method of transmitting sounds by the energy of air-waves and electricity.

That in either case the 5th claim is not infringed by the method or apparatus used by the defendants.

That neither the 5th, 6th, 7th or 8th claims of the patent, No. 186,787, are infringed by the receiver used by the defendants.

That the judgment of the Court below should be reversed, and the cause remanded to the Court below, with instructions to dismiss the bill, with costs.

Messrs. GEORGE F. EDMUNDS, DON M. DICKINSON, CHARLES P. CROSBY, LYSANDER HILL, T. S. E. DIXON, HENRY C. ANDREWS and MELVILLE CHURCH for the People's Telephone Company (Drawbaugh case), and the Overland Telephone Company:

From Bell's sworn preliminary statement in the "Speaking Telephone Interferences" (Complainant's Record, p. 1695) the following facts clearly appear, viz.:

That prior to the summer of 1874 Bell had formed no conception of any means for the transmission of speech. In the summer of 1874, stimulated by Helmholtz's experiments in the electrical transmission of vowel sounds by means of a series of tuning forks of different pitch, Bell conceived the



## Argument of counsel.

possibility of accomplishing "the same results" by substituting a series of vibrating reed armatures in place of Helmholtz's tuning forks. But he never, then or at any subsequent time, made or attempted to make or test such apparatus.

In the summer or fall of 1874, he also formed an inchoate mental conception of the possible production of a similar result by means of a "membrane similar in shape and structure to that in the human ear," but, although he spoke of the plan to Dr. Blake in October, 1874, he did not devise any method of combining the membrane with an armature, or attempt to construct any apparatus upon the plan.

In March, 1875, he explained his "harp apparatus" to Professor Henry, and it was of this apparatus, and not of the membrane apparatus, that Professor Henry spoke as containing "the germ of a great invention."

About May 4, 1875, he made an experiment to test the transmission of an electric current through piano strings in vibration. The experiment was a failure.

On June 2, 1875, Bell accidentally discovered that with two multiple-telegraph instruments, arranged in circuit as shown in Fig. 5 of his subsequent patent of March 7, 1876, he could, upon plucking one of the reeds with his finger, hear an audible response from the other, of the same pitch as the normal pitch of the transmitting reed, and with something of the timbre of that reed.

Thereupon Bell, for the first time in his life, conceived the practical possibility of transmitting articulate speech by a membrane instrument, and set about to construct one.

One was completed on July 1, 1875, and another a few days after, and with these two instruments Bell and Watson experimented in July, and, at the end of that month, discontinued their experiments without having heard a word of speech through the device, and even without Bell's having been able to hear a sound.

No further experiments were made till March 10, 1876, after the date of the first patent here in suit; but then the

## Argument of counsel.

experiments were resumed, not with the instruments of July, 1875, but with a liquid transmitter and one of the old multiple-telegraph instruments as a receiver, and then, for the first time was obtained, to use Bell's words, "*intelligible articulation.*"

Prior to June 2, 1875, Mr. Bell never made a telephone instrument or experiment, his work being confined exclusively to his multiple and autograph telegraph inventions, and to his professional work as a teacher of the deaf.

Bell obtained his first reproduction of speech electrically through Gray's liquid transmitter, on March 10, 1876, a few days after he had acquired knowledge of Gray's caveat at Washington.

Bell had never made, nor attempted to make, such a transmitter until after he had knowledge of Gray's caveat.

All of Bell's telephonic apparatus and experiments, prior to his knowledge of Gray's caveat, were magneto-electric apparatus and experiments.

After getting speech through Gray's liquid transmitter, on March 10, 1876, he immediately resumed experiments with his magneto-electric current and apparatus for speech transmission, but reconstructed the apparatus, and in April got speech through it.

This reconstruction apparatus was not like his apparatus of July, 1875, but was exactly like the receivers shown in Gray's caveat.

After the demonstration of electric speech on March 10, 1876, it was too late to amend or change the patent, which had been issued three days before. But it was not too late to amend the application so as to broaden its possible construction.

A more startling fact appears in the record, to wit: that Pollock & Bailey, Mr. Bell's attorneys, had an underground railroad in operation between their office and Examiner Wilbur's room in the Patent Office, by which they were

## Argument of counsel.

enabled to have unlawful and guilty knowledge of Gray's papers as soon as they were filed in the Patent Office.

There is indubitable evidence that an important invention, and a claim therefor, were bodily interpolated into Bell's specification, between February 14, 1876, and February 19, 1876, by Pollock, in consequence of the guilty knowledge which the latter already had of the contents of Gray's caveat, before the declaration of interference with Gray on February 19. This interpolated claim was the *fourth* claim.

The interpolated new invention was the passage found on the fifth page of Bell's printed specification, to wit:

“Electrical undulations may also be caused by alternately increasing and diminishing the resistance of the circuit, or by alternately increasing and diminishing the power of the battery. The internal resistance of a battery is diminished by bringing the voltaic elements nearer together, and increased by placing them farther apart. The reciprocal vibration of the elements of a battery, therefore, occasions an undulatory action in the voltaic current. The external resistance may also be varied. For instance, let mercury or some other liquid form part of a voltaic circuit, then the more deeply the conducting wire is immersed in the mercury or other liquid, the less resistance does the liquid offer to the passage of the current. Hence, the vibration of the conducting wire in mercury, or other liquid included in the circuit, occasions undulations in the current. The vertical vibrations of the elements of a battery in the liquid in which they are immersed, produces an undulatory action in the current by alternately increasing and diminishing the power of the battery.”

We have three Patent Office copies of Bell's specification, all of which ought to agree. But here the remarkable fact appears that, while the specification, printed March 7, 1876, as a part of the patent, and the photographic fac-simile of October 30, 1885, agree almost exactly with each other, neither of them agrees with the certified copy of April 10,

## Argument of counsel.

1879. Yet each, being a certified copy, imports verity, and proves that the record stood as certified, at the time of its certification.

There are thirty-nine separate statements in the certified copy of April 10, 1879, which disagree with the statements respectively found at the same places in the patent and in the photographic fac-simile; and every one of those thirty-nine separate statements in the copy of April 10, 1879, is an exact copy of the language found in the same connection in the George-Brown paper.

The thirty-nine passages correspond so curiously to the George-Brown copy, mistakes and all, that the entire correspondence of the whole original Patent Office specification with the George-Brown copy can no longer be doubted.

The George-Brown copy, originally written in October, 1875, was revised and corrected before it was handed to Mr. Brown at New York, on or about January 25, 1876. Before revision, the George-Brown copy was not verbatim the same as the American specification—after revision, it was a verbatim duplicate.

It follows, therefore, that it was not revised and corrected until the American specification was completed.

The American specification was not completed till January 1-10, 1876, and was not thereafter changed in any respect till filed. The George-Brown copy, therefore, was not revised and corrected to assume its completed form until as late as January 1-25.

The variable-resistance matter was, therefore, not in the American specification between January 1-10, 1876.

The patent of January 30, 1877, should be strictly limited to the magneto form of instrument.

If Bell, in January, 1877, attempted to weave the variable-resistance current or apparatus into his new telephone patent, and to make descriptions and claims to cover it, there was no inadvertence, accident or mistake about the matter; it was deliberately done to defraud and deceive the public, and

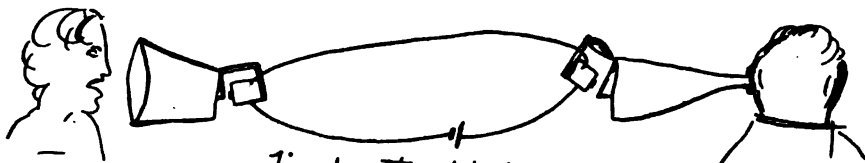

First attempt to transmit  
the human voice. The varying pitch of  
the voice could be discriminated but not  
the quality. ~~When~~ A sort of muttering  
effect was perceived at the receiving end  
when a person talked very loudly at the other  
end -

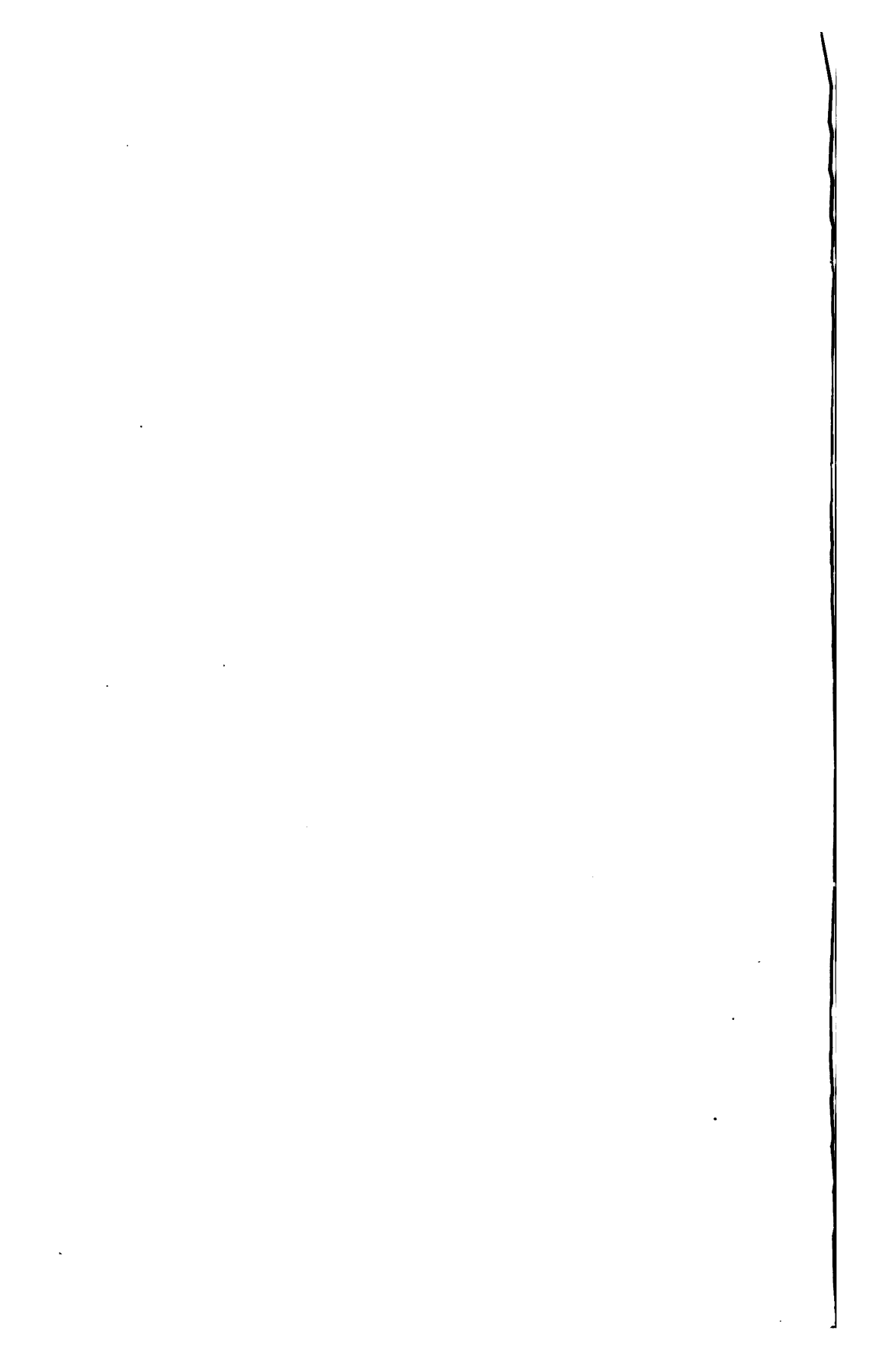

## Argument of counsel.

to cover and appropriate the invention of another, and the whole patent is clearly void.

Bell made a sketch at Toronto on the 28th of December, 1875, for the information of Mr. George Brown, which shows the invention and apparatus described in Bell's United States patent, dated March 7, 1876, of which the following is a copy.

The explanatory passage accompanying the sketch, which Bell declares was intended to illustrate the form of speaking telephone at which he had then arrived, and written by him, to be shown to Mr. Brown in explanation of the very matter in which he was then endeavoring to induce him to become personally interested, must be regarded as a *bona fide* statement by Bell, in the strongest permissible language, of the actual results that had then been achieved in his first attempt to transmit the human voice.

Bell had found it impossible, as yet, to construct an armature, and so combine it in an apparatus that its vibrations should actually correspond to the air vibrations accompanying a sound, or, in the language of his patent, so that it should cause "electrical undulations similar in form to the vibrations of the air accompanying the said vocal or other sounds."

But, notwithstanding this acknowledged failure, Mr. Bell, nevertheless, determined to patent the *principle*, leaving to the future to discover the means of utilizing it.

"In its naked, ordinary sense, a discovery is not patentable. A discovery of a new principle, force of law, operating, or which can be made to operate on matter, will not entitle the discoverer to a patent. It is only where the explorer has gone beyond the mere domain of discovery, and has laid hold of the new principle, force or law, and connected it with some particular medium, or mechanical contrivance, by which, or through which, it acts on the material world, that he can secure the exclusive control of it under the patent act."

## Argument of counsel.

Morton v. New York Eye Infirmary, 5 Blatch. 121; Burrall v. Jewett, 2 Paige, 143.

He is the inventor, and is entitled to the patent, who first brought the machine to perfection, and made it capable of useful operation.

Agawam Woolen Co. v. Jordan, 7 Wall. 602 [8 Am. & Eng. 24]; Whiteley v. Swayne, Id. 687 [8 Am. & Eng. 70].

Until the invention is perfected and adapted to use, it is not patentable under the patent laws.

Seymour v. Osborne, 11 Wall. 552 [8 Am. & Eng. 290]; O'Reilly v. Morse, 15 How. 62 [5 Am. & Eng. 483]; Burr v. Duryee, 1 Wall. 531 [7 Am. & Eng. 224].

Granting their validity, what construction shall be given to letters patent, No. 147,469, granted to Mr. Bell, March 7, 1876, and in particular to the 5th claim?

The whole fabric of Bell's reasoning, by which he has arrived at certain advantageous conclusions, is based directly upon the possession, by the "undulatory" current, of the very qualities which alone characterize the magneto-electric current.

Bell's statement that this "present invention consists in the employment of a vibratory or undulatory current of electricity, in place of a merely intermittent one, and of a method of, and an apparatus for, producing electrical undulations upon the line-wire," is thus clearly seen to be a statement made directly in the execution of the purpose he had formed to patent "the use of the magneto-electric current."

The newly-described current of varying resistance has not been claimed by Bell, in his patent, for use in the transmission of speech, but for multiple-telegraph purposes alone.

Moreover, the *modus operandi* of the newly-described current of varying resistance when employed in the transmission of speech, is wholly different from that of the magneto-electric current under similar circumstances.

Everything points to the conclusion that Bell appropriated to himself the ideas set forth by Mr. Gray in his caveat.



## Argument of counsel.

First, by means of the new passage and claim interjected into his patent; and secondly, by embodying in the construction of instruments, both the varying resistance and the magneto, and instruments through which he for the first time transmitted articulate speech.

Messrs. E. N. DICKERSON, CHAUNCEY SMITH and JAMES J. STORROW, for the American Bell Telephone Company:

The charge of forgery has been made, fully and elaborately in two of the briefs for the Overland and Drawbaugh Companies.

A forgery committed on the paper in the Patent Office, besides an interpolation; and that the papers were twice stolen from the files in the Patent Office, taken away, and new papers put in place of them as and for the originals.

There has never been in this case, up to last week, any hint, any charge, any insinuation, any suspicion of such a crime, as is now charged. There is no such issue made in the case; I mean no issue which called upon us to put in any evidence bearing upon such charges. It is a new thing.

Bell, before he went to Washington in February, 1875, knew the substance of Gray's invention, because Gray had been describing it in the newspapers; not the speaking telephone, but the harmonic multiple telegraph.

Bell, in the fall of 1875, made a draft of a specification for his patent. The description which he wrote of that in the fall of 1875 stands to-day in the patent exactly as he then wrote it.

He completed his American application in January, 1876. The production of the certified copy of the application itself from the files of the office has that clause exactly as it stands in the patent.

That sort of way of producing undulations—*by varying the resistance*—was not new in Mr Bell's mind at that time. His letter of May 4, 1875, had said that he feared that the magneto mode—that is, by vibrating an armature, would give currents which would be too feeble to be practically

## Argument of counsel.

useful, and therefore he thought the true way would be to use a battery current, which can be made as strong as is desired.

As early as May 4, 1875, Bell had conceived of the variable-resistance plan as the equivalent of the magneto plan for the transmission of speech. The charges that are made against Bell are, that the paper which he filed on February 14, 1876, as his application, was a copy of the George-Brown specification as written in 1875; and that the application so filed did not have this variable-resistance idea in it. The application was filed on the morning of February 14, Gray's caveat was filed on the afternoon of February 14.

Bell was not in Washington that week at all. The charge is that Messrs. Pollock & Bailey got a dishonest sight of Gray's caveat, found the liquid transmitter in it, determined to steal the idea for Bell, did so, abstracted from the files of the office half a dozen sheets, more or less, of Bell's pending application, wrote the stolen idea in, returned the sheets and sewed them up again, and let them stand as if they were the honest original application.

The next charge is an intimation that the examiner in charge of that room was in collusion with them and aiding them.

Now the very first action of that examiner was to say: "Gray's caveat is here, and you cannot have your patent." These men, who owned him, body and soul—that is the insinuation—were blocked by him at the very first thing he did.

Gray never proceeded. He had never made an instrument in accordance with his caveat. All the acts of the examiner, therefore, were pointedly in favor of Gray. The next part of the charge is, that after Messrs. Pollock & Bailey had committed this theft and interpolation, Bell came to Washington, and they then told him what they had done, and he ratified it and approved of it. This is all their imagination. There is not a word of any such thing in the testimony, not a suggestion of it anywhere until last week.

## Argument of counsel.

They say Bell then went to the Patent Office and changed "tone" to "note," etc. There are over thirty, so they pretend, such changes made by him at that time. And he went on to change thirty-eight words in the specification.

They say that the paper, as thus altered in pencil, read as the patent reads, and thus altered, came to be the patent as it was printed and issued. But there is not a word of testimony on this subject. It is all pure conjecture.

The whole charge finally comes down to this keystone, that the paper on the files to-day is (so they say) not the paper which was on the files in 1879; which they say they find from the fact that the paper there to-day is not the paper as printed in the Dowd record and in the Drawbaugh record.

Mr. Storrow here states: "The way it came to be so printed is this: A certified copy was procured by me, or through Mr. Pollock, in 1879, for my own use. That copy was put in evidence in the Dowd case. Upon that copy I, with my own hands, in 1879, interlined words from the George-Brown specification."

*The duration of the sound may be used<sup>made</sup> to indicate<sup>signify</sup> the dot or dash of the Morse alphabet — and thus a telegraphic dispatch may be indicated<sup>can be transmitted</sup> by alternately interrupting and renewing the sound.*

"The original exhibit itself shows (it has got the printer's marks on it) that it went to the printer, and the printer in printing it printed in the words which I had written in pencil for my private memoranda."

A letter was here handed to the Court, written by Mr. Storrow to Mr. Andrews, counsel for the Drawbaugh Company, dated New Orleans, February 18, 1886, as follows:

## Argument of counsel.

“I want to make one correction in the original record of the Drawbaugh case. The file of the Bell patent is in evidence, but the copy of the application is not printed correctly. I believe there are no errors in it which are of any importance, but there were some pencil marks on the copy that went to the printer in the Dowd case, with brackets, etc., and that got reproduced in your case. There has been lately printed a very careful and accurate copy from a photograph of the original papers, and I directed two copies of this to be sent to you from Boston. I propose to you to substitute that for the print that now exists among our exhibits in the Drawbaugh record, and also to stipulate, as enclosed, that the Court on appeal, may, if it desires, refer to a certified copy made by the Patent Office, for greater accuracy.”

And a stipulation was here read as follows:

“It is agreed that upon the appeal of this case (The American Bell Telephone Company v. The People’s Telephone Company), the Supreme Court may, if it desires for greater accuracy, refer to a copy of the Bell patent and file made and certified by the Patent Office.” Signed “L. Hill, solicitor for defendants,” and enclosed in a letter which read: “Herewith please find enclosed stipulation, that parties may, on the appeal, refer to a copy of the Bell patent on file, certified to by the Patent Office.”

A similar letter, requesting the correction, though not stating the reasons so fully, was sent to the Overland Company, September 30, 1886, and they had the new print put into their record.

In the Drawbaugh case they put the print into their record; they reprinted it themselves, at their own expense, and followed it by the note which you will find there (Drawbaugh, Overland Proofs, p. 764).

The original paper from which the transcript was made, which is printed in the Drawbaugh case, was here produced and handed to the Court.

A fac-simile of the certified copy was here handed to the

## Argument of counsel.

Chief Justice. All the pencil marks of the exhibit are here printed in blue. The following is a reproduction of one of the altered sentences, showing the pencil interlineations made by counsel and erroneously printed.

The various words in blue ink are the words interlined in pencil in the original exhibit. The certified copy read in ink exactly as the patent now does, "dependent for effect upon the variations," etc.

The pencil interlineations in that copy were made by scoring out the syllable "ent," and interlining "but all of them," thus:

*There are many ways of producing  
inductory currents of electricity, <sup>but all of them</sup> depen-  
dent for effect upon the vibrations  
or motion of bodies capable of induc-  
tive actions*

The interlined words were the words of the George-Brown copy, written in, in pencil between the lines.

March 26, 1878, interferences were declared in the Patent Office between Bell's patents and the applications of Elisha Gray, J. W. McDonough, T. A. Edison, A. G. Holcombe, A. E. Dolbear, and W. L. Voelker. Evidence was then taken, and the interferences were argued before Mr. J. B. Church, Examiner of Interferences.

He thereupon decided in favor of Bell every issue which, in his opinion, involved the invention of the speaking telephone.

His decision was appealed from by the various parties, and was heard before the Board of Appeals. In the fall of 1884, such Board unanimously decided every issue in favor of Bell.

This decision was appealed from, and the appeal was argued before Mr. Commissioner Butterworth in person.

## Argument of counsel.

March 8, 1885, he affirmed the decision of the Board in favor of Mr. Bell, on all points.

The string telephone has been spoken of by counsel. It is two hundred years old in its various forms. The following is a representation of it:

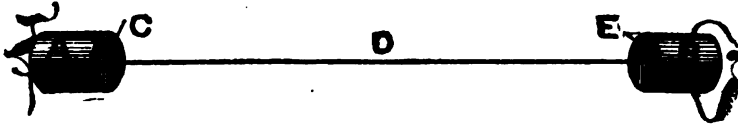

It consists of two tubes, or little tin cases, A and B with a bladder, C and E, stretched over one end of each. A string (D) has one end passed through the center of each, and tied with a knot inside. If I speak into it at A, a person listening at B will hear what I have said. I may make this string a hundred feet long, and carry it into the next room; then if I speak into this, a person in the other room will hear what I say.

What produces the sensation of sound on the ear is the vibration of the air, set in motion by the source of sound, and reaching the ear. All you have got to do to make a person hear the sound is to produce sonorous vibrations of the appropriate kind next to the ear, and the way in which this string telephone does that is, that when you speak into this at A you set its diaphragm in vibration, and it copies the vibrations which the voice produces in the air.

The same air vibrations produced by the voice at one end are reproduced by the diaphragm at the other.

The problem for the inventor of the electric-speaking telephone was to take away that string, and connect those two diaphragms by electricity.

The following is a representation of the Morse instrument: B is the battery; K is the key. The current comes from the battery B to the key K.

When the key is in the position represented in the cut, the two parts K and K' are not in contact, and no current can pass. When I press down the key K so that it touches the

## Argument of counsel.

“anvil” K' they come in contact, and a current can pass; and when it passes it converts the pieces of soft iron inside of those coils at E into magnets for the moment; and that magnet pulls down the armature A (normally held back by the

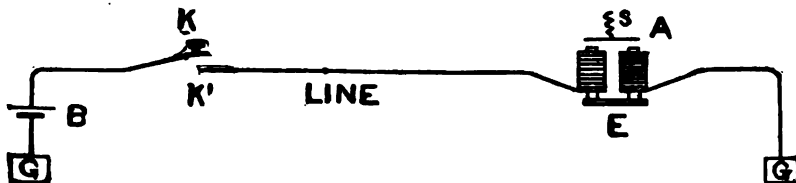

spring S), and that makes the click which you hear. By that instrument I can produce motion at a distant place. I can produce a sound at a distant place; and I can produce just as many motions as I want. But that is all that I can do. That will not accomplish the transmission of speech.

The sound in the air is due to the vibrations in the particles of air.

More vibrations per second give a higher pitch of sound. Vibrations have, in the language of acoustics, a greater or less amplitude which determines the loudness of the sound.

There is a characteristic of sound which distinguishes one sound from another, which is neither loudness nor pitch. The characteristic which distinguishes the sound of a violin from that of the human voice or of a flute, which distinguishes one word from another, and which technically is called “quality,” depends upon the way in which it performs its journey within its allotted time and over its allotted path.

(Counsel here explains the phrase “form of vibration,” by reference to cut given at page 319, *ante*.)

Suppose I attach a pencil to an air particle, while it is vibrating; then if I place a piece of paper under the point of the pencil, I shall get a wavy line. That waviness is due to the vibration. If it vibrates in a different way it will make a different wavy line; each difference of waviness depends upon the way in which this vibrates. The character of its vibration is expressed by the waviness of the curve. From

## Argument of counsel.

exhibiting to the mind a conception of the motion of an air particle, by means of wavy lines drawn, or supposed to be drawn, by an air particle with a pencil fastened to it, people came to speak of the "form of vibration;" by which they do not mean that the particle moves in a sinuous or crooked line, for it moves in a perfectly straight line to and fro. They mean, by that phrase, to signify the curve which the particle would draw if a pencil were fastened to it while vibrating, and a piece of paper were drawn under it.

## THE BELL TELEPHONE.

The first diagram here given is a drawing of Fig. 7 of Bell's patent. The other is a telephone transmitter like said Fig. 7, without adjustment.

In the first diagram, a piece of iron hangs down, marked *c* at the lower end of the corner *A*. The upper end is hinged so that it is free to move. At the lower end, marked *c*, it is fastened at the centre of the membrane *a*. *b* is an electro-magnet. It consists of a bar of soft iron, one end of which just juts out near *c*, with coils of wire wound around it.

As the armature *c* is hinged at the upper end so that its lower end *c*, fastened to the centre of the stretched membrane at *a*, can move freely, whenever that stretched membrane is vibrated by the voice the armature moves just as the membrane does. When this armature *c* is moved or waved in front of the electro-magnet *b*, it induces electrical disturbances in the coil of that magnet.

One end of that coil is connected with the conductor or line-wire *e*, which goes off to the distant station; and as that line-wire is a conductor of electricity, the flow which the disturbance in the coil, caused by waving the armature, tends to produce finds an outlet in that conductor, and the electricity will rush through the conductor *e* to the other instrument *L*.

The essential thing in the mechanic part of this particular instrument is: that there shall be a diaphragm, or its me-



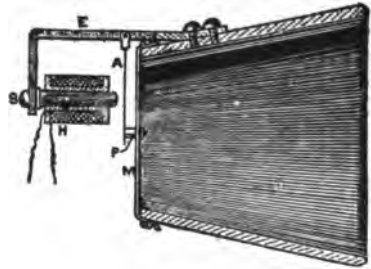
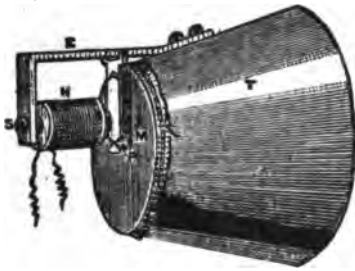
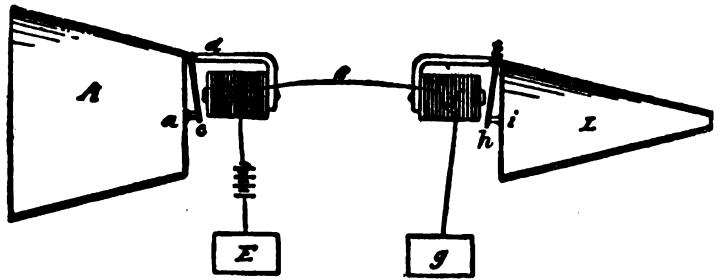

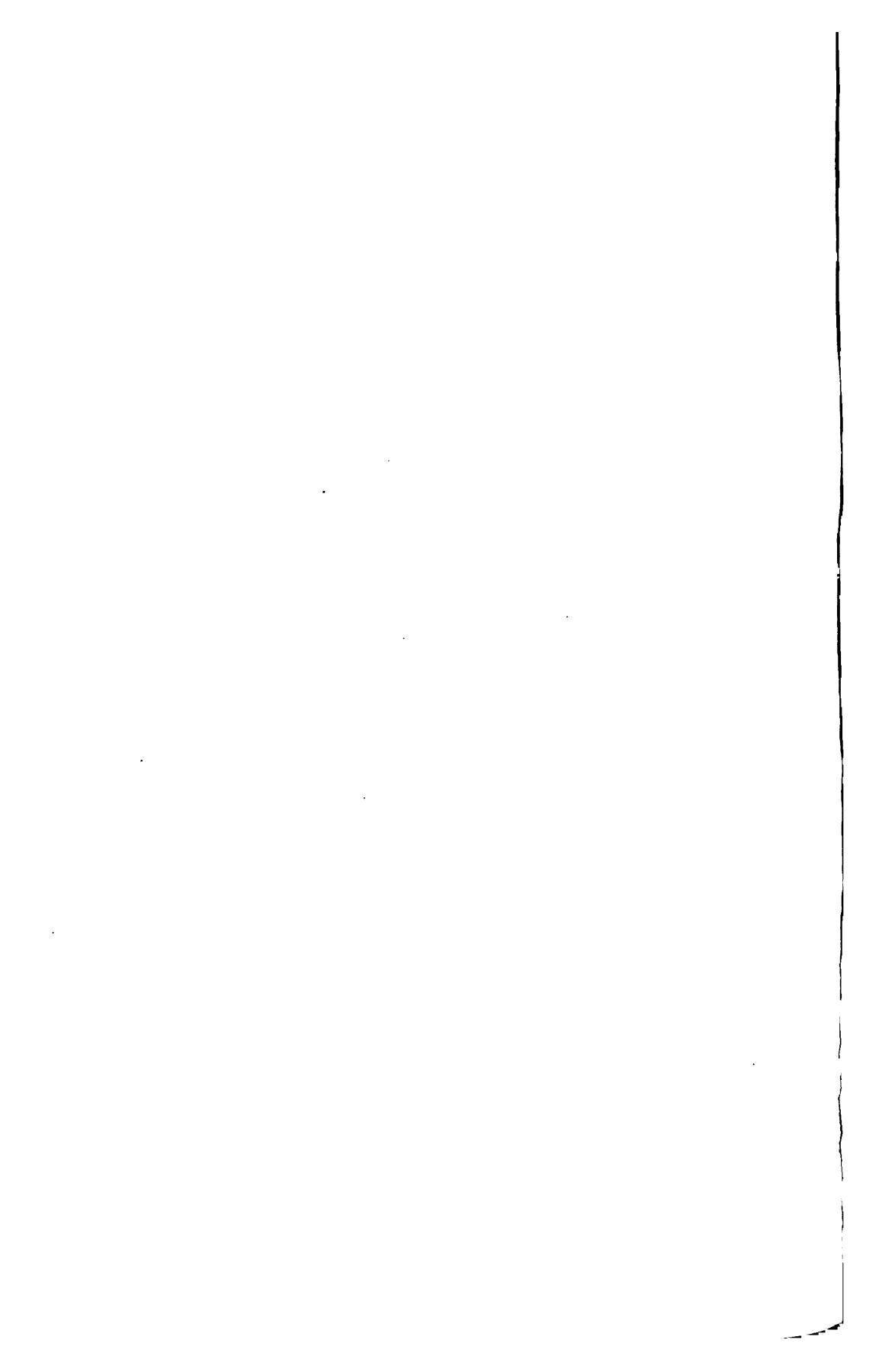

## Argument of counsel.

chanical equivalent, capable of vibrating under the influence of the sound-waves produced by the voice or by any other source of sound ; that an armature shall be fastened to that so that it will move just as the diaphragm does ; then that the armature shall be thus moved close in front of the electro-magnet.

Currents generated in the transmitter *A* pass to the electro-magnet *f*, of the receiving instrument *L*, and as they go around that electro-magnet they cause its core to become more or less magnetic, and cause its magnetic strength at each particular instant to correspond to the motion that is going on in the transmitter at that instant. That electro-magnet pulls this armature *h*.

The varying pull of the magnet is just in accordance with the variations of the current.

The diaphragm of this receiving instrument, not only in the fact of motion, but in every variation in the sequence of its successive motions, to the minutest degree, copies the variations in the movements of this transmitter-diaphragm. The result is that we have got now, by means of electricity, what the string-telephone man had with his string. We have got the receiving diaphragm to copy by electricity the motions of the transmitting diaphragm. That is the Bell telephone.

The motions at the receiver are a copy of the electrical changes ; the electrical changes are copies of the motions at the transmitter. If that holds true, then the thing will talk. Then the same character of vibrations—not only the same number, but the same character of vibrations—which takes place here at the transmitter will take place there at the receiver.

The particular novelty of Bell's contrivance, the novelty of principle, which he first introduced into science and the arts, was not that he was the first who wanted to transmit speech by electricity ; it was not that he was the first who saw that to reproduce speech by electricity or by any other way you must have some distant diaphragm—or it need not

## Argument of counsel.

be a diaphragm, it may be a piece of board, or anything else—copy the vibrations at the receiving end, for the string telephone had done that; he was the first man who conceived of, or who embodied in any description or machine, the conception that in order to do that you must have the electrical disturbances in the wire and in the circuit to be copies of the sonorous disturbances at the transmitter end.

People had been trying to make electrical speaking telephones for many years, but it never occurred to any of them that the electrical disturbance which would accomplish the result was to be one which itself should be a copy of the sonorous vibrations at the transmitting end. That was Bell's conception, and he worked it out.

That made his thing to be a speaking telephone, and the fact that no such conception had been reached or was embodied in any previous man's instrument prevented any previous man's instrument from being a speaking telephone.

These electrical changes are not a manufactured product. You can't take them out of the machine; they are made in the machine, to be used in the machine. The *result* is the transmission of speech. That is what was aimed at.

But these electrical changes are not results. They are made to be used at the instant of their creation.

One of the gentlemen told you that Bell and the owners of the patent wanted to monopolize the transmission of speech, by whatever means. Nothing of the sort. We want to monopolize this particular means which Bell has introduced into electrical science. If anybody can do it any other way, he has a perfect right to do it.

It would be impossible to extend this patent to cover means other than those which come within what he first introduced into the art.

This kind of electrical changes is not a thing that exists in nature like coal and iron and wood.

Bell didn't discover something that existed in nature, and undertake to patent that. He *created* something. These

## Argument of counsel.

undulations are something "created by the hand of man;" or perhaps I should say, by the voice of man. They did not exist before he created them.

He has told you how to create a set of electrical disturbances, and he has told you that when you create those electrical disturbances *you can get speech* by means of them. "You can't get it without them," says Mr. Dolbear. Those electrical disturbances are the *essential novelty* of his apparatus.

The patent law, in express terms, says that you are to describe your machine, and "the principle" thereof, "by which it may be distinguished from other inventions." That is not all you are to do. You are to describe, says the patent law, "the best mode in which you have contemplated applying that principle."

The patent is to be in terms for the "invention or discovery," and not for any particular mode of application.

The Patent Act, by its terms, as the Courts have always done, intends, expects and perceives that a man even may himself contemplate many modes, not only many machines for applying his invention, but many *modes* for its application. It intends that his patent shall be for his *whole invention*, and he has only to describe one mode of applying it. He has to describe one, because until he has done that he has not entered into the improvement of the useful arts, and has not brought himself within the domain of the patent law. When he has done that his patent is for his whole invention.

Bell *v.* Gray, 15 Off. Gaz. 778; Househill Co. *v.* Neilson, Web. Pat. Cas, 683, 715; Evans *v.* Eaton, 7 Wheat. 356 [4 Am. & Eng. 105]; McClurg *v.* Kingsland, 1 How. 202 [4 Am. & Eng. 382]; LeRoy *v.* Tatham, 14 How. 156 [5 Am. & Eng. 313]; O'Reilly *v.* Morse, 15 How. 62 [5 Am. & Eng. 483]; Winans *v.* Denmead, Id. 330 [6 Am. & Eng. 107]; Parker *v.* Hulme, 1 Fish. Pat. Cas. 44; Corning *v.* Troy, I. & N. Factory, 15 How. 451 [6 Am. & Eng. 144]; Burr *v.* Duryee, 1

## Argument of counsel.

Wall. 567 [7 Am. & Eng. 224]; *Jacobs v. Baker*, 7 Wall. 295; *Haworth v. Hardcastle*, Web. Pat. Cas. 484 [2 Am. & Eng. 19].

Specifications are to be construed liberally, in accordance with the design of the Constitution and the patent laws of the United States, to promote the progress of the useful arts, and allow inventors to retain to their own use, not anything which is matter of common right, but what they themselves have created.

*Grant v. Raymond*, 6 Pet. 218 [4 Am. & Eng. 245]; *Ames v. Howard*, 1 Sumn. 482, 485; *Blanchard v. Spague*, 3 Sumn. 535, 539; *Davoll v. Brown*, 1 Woodb. & M. 53, 57; *Parker v. Haworth*, 4 McLean, 372; *Neilson v. Harford*, Web. Pat. Cas. 341; *Russell v. Cowley*, Id. 470 [1 Am. & Eng. 489]; *Corning v. Burden*, 15 How. 252 [6 Am. & Eng. 69]; *Mitchell v. Tilghman*, 19 Wall. 287 [9 Am. & Eng. 174]; *Tilghman v. Proctor*, 102 U. S. 708 [13 Am. & Eng. 29]; *Cochrane v. Deener*, 94 U. S. 787 [11 Am. & Eng. 288]; *James v. Campbell*, 104 U. S. 377 [13 Am. & Eng. 341]; *McCormick v. Talcott*, 20 How. 402 [6 Am. & Eng. 410].

A patentable invention is a mental result. The intellectual element is recognized as the test of identity, for anticipation and infringement.

*Waterbury Brass Co. v. Miller*, 9 Blatch. 77; *Smith v. Nichols*, 21 Wall. 118 [9 Am. & Eng. 425]; *Bischoff v. Wethered*, 9 Wall. 812 [8 Am. & Eng. 213]; *Clough v. Barker*, 106 U. S. 166 [14 Am. & Eng. 211]; *Blake v. Robertson*, 94 U. S. 728 [11 Am. & Eng. 266]; *Pennsylvania R. Co. v. Locomotive E. S. Truck Co.* 110 U. S. 490 [15 Am. & Eng. 148]; *Consolidated S. Valve Co. v. Crosby S. G. & Valve Co.*, 113 U. S. 157 [15 Am. & Eng. 460]; *Blake v. San Francisco*, Id. 679 [15 Am. & Eng. 535]; *Miller v. Foree*, 116 U. S. 22 [16 Am. & Eng. 193].

Bell made one speaking telephone. He described one speaking telephone. Let me assume that he made only one. But the merit of that specification was that he laid down the rule for all future speaking telephones. He said, "get

## Argument of counsel.

into the operation of that machine this which never was in any machine before, and get it in, in accordance with a particular rule," which he stated. Now, every man who has endeavored to improve this speaking telephone since that time has endeavored, not only to avail himself of the fact that Bell found, but has endeavored to conform more and more perfectly to the rule which Bell laid down.

I have described the operation of that particular machine, but I have not described the whole of it. If Your Honors will look again at Fig. 7, you will find that beside the

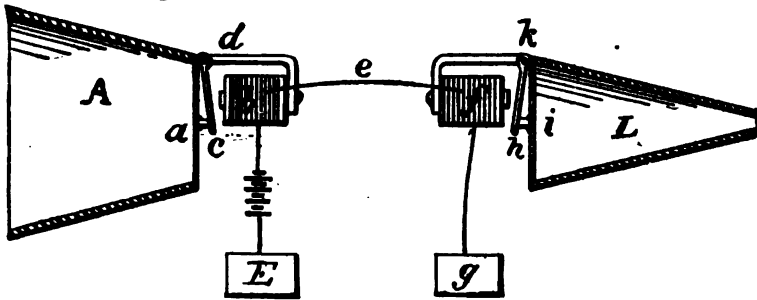

electro-magnet which generates the currents I spoke of, there is a battery in the circuit, shown conventionally by the cross lines, just above E. Now, what happens? The battery sends along a big strong current, which I will represent by a big space between those two lines. The magneto machine (which is the transmitter) is adding to or subtracting from that current, according to the direction of the motions of its armature. It is doing that, and in doing that it is adding a little or is taking away a little of the electric energy from that great stream. Now it adds a little, and now subtracts a little. It makes it a little stronger, or a little weaker. Those changes are very small as compared with the whole. It cannot take away enough to stop it entirely. It makes it a little stronger and a little weaker. The result is that in Fig. 7 of the patent, according to the description of the patent, you get a great, strong stream, always fairly strong, sometimes a little stronger, and sometimes a little weaker.

## Argument of counsel.

It is that stream, or rather the variations of its strength, which work the receiver. Sometimes it pulls it a little stronger, and sometimes it pulls it a little less.

## THE MICROPHONE.

I have here a battery, and a wire from each pole or plate of the battery. If those two wires join so that they make one wire, the current flows through them around the circuit. If I separate them, the current ceases to flow. That is what is called "opening" the circuit. Opening the circuit is opening the wire. When I put them together again the current flows. When I put them together again, I cannot make so good a union as there was between the particles of the uncut wire. The current does not flow so strongly.

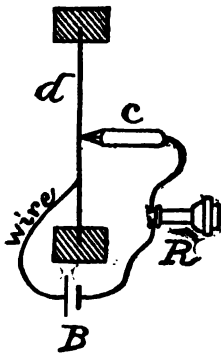

Suppose I have one of the wires beaten out into the form of a diaphragm *d*, and bring the other *c* up to it so that they touch; the current will pass; and if I press them more strongly together the current will pass more strongly; if I press them together weakly the current will be enfeebled. The changes in the current will correspond to the variations of pressure at this point of contact. Suppose now, holding that wire-end *c* there, I speak to the back of this diaphragm

*d*, and make it vibrate gently, not enough to part contact between the diaphragm *d* and the wire-end *c*, but enough to make it vary this pressure, as when I press my thumb with a slight pressure, or a greater pressure, on the table. Thus variations of pressure will be caused by the voice; and not only will they be *caused* by the voice, but the variations of pressure will *correspond* to the vibration which this diaphragm *d* performs under the influence of the voice.

That is the principle of the microphone. It was invented, in the United States, by Mr. Berliner and Mr. Edison in 1877, independently of each other. It was invented independently, by Hughes, in England, in 1878.



## Argument of counsel.

When coupled with a receiver it constituted an improved form of the Bell apparatus.

The essential mechanical features of the microphone are: (1) that the parts should be so constructed that one electrode can be vibrated by the voice while in contact with the other, and that the other shall be so arranged as to mechanically so resist that motion that it shall result in variations of pressure; and (2) that the parts should be so constructed and arranged that the vibrations given to one electrode by the ordinary action of the voice shall not break the contact under ordinary circumstances.

In the diagram, which is taken from an application filed by Edison in July, 1877, the carbon electrode C is mounted on the end of a spring E, strained by a screw F towards the diaphragm electrode D to prevent breaks of contact.

The problem which the microphone solves is this: to introduce into an electrical circuit an electrical resistance, *which resistance shall be in exact accord with sonorous vibrations.*

It is a law of electricity that the strength of the current in the circuit depends upon the amount of electrical energy used to create it, and it also depends upon the resistance.

Hughes' microphone is a contrivance which will produce the same changes in the electric current—the same sequence of successive strengths in the current—by varying the resistance that Bell had in Fig. 7.

The form in which that is commercially used is shown in the Blake transmitter.

Here is a long cast-iron lever L, hinged at the upper end. At the lower end is a screw N, which enables that lever to be moved a little. Down inside you will find a very slender spring A that comes from the upper end. It goes down to

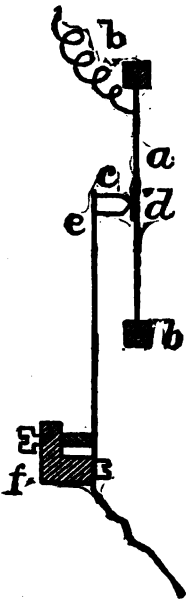

## Argument of counsel.

the centre of the diaphragm, and carries a little knob of platinum K, about as big as the head of a pin. The steel spring S is clothed with India rubber, with a brass knob W at the end. If you draw that back against the large lever, you can separate it from the platinum knob. The electric current comes down through the inner slender spring to the platinum point K, thence passes to C, a little piece of carbon; thence through W, up the spring S, and around to the battery B again. The mouthpiece P is a hole in M. Inside of that, fastened to this rim F is a disk or diaphragm D, of sheet iron. There is a little packing or fold of rubber around its edges. Plate D can come out, and is free to vibrate. When I speak into it through mouthpiece P, I vibrate it like the diaphragm of the string telephone. The thrust which the diaphragm makes against K bears against the carbon C.

The trick in the microphone is to get those parts arranged so as to develop the increase and diminution of pressure as much as possible, but to still keep them always in contact, and that is the end of the business.

The function of spring E is to hold that diaphragm in place. If you take that spring away, and this little clip E', away, the diaphragm would fall out.

There are nearly five hundred thousand of those telephones in this country. I suppose that there are as many more in other parts of the world. Who originated them? Every speaking telephone at work in the world traces its origin right up to Bell. There were no speaking telephones used before Bell made one. Bell is the inventor of it. It was not known before.

And yet the defendants set up that the Reis apparatus was known to the whole world as a speaking telephone, and that nobody of any sense or intelligence ever supposed that Bell was the first inventor.

That the Reis publications, though well known, never in fact taught men how to make a speaking telephone, is *conclusive proof* of their insufficiency.

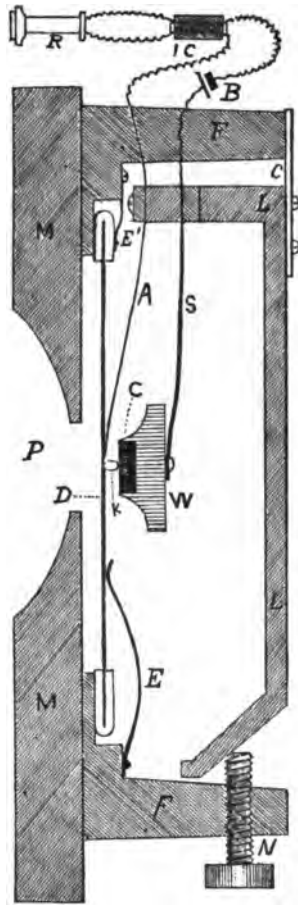

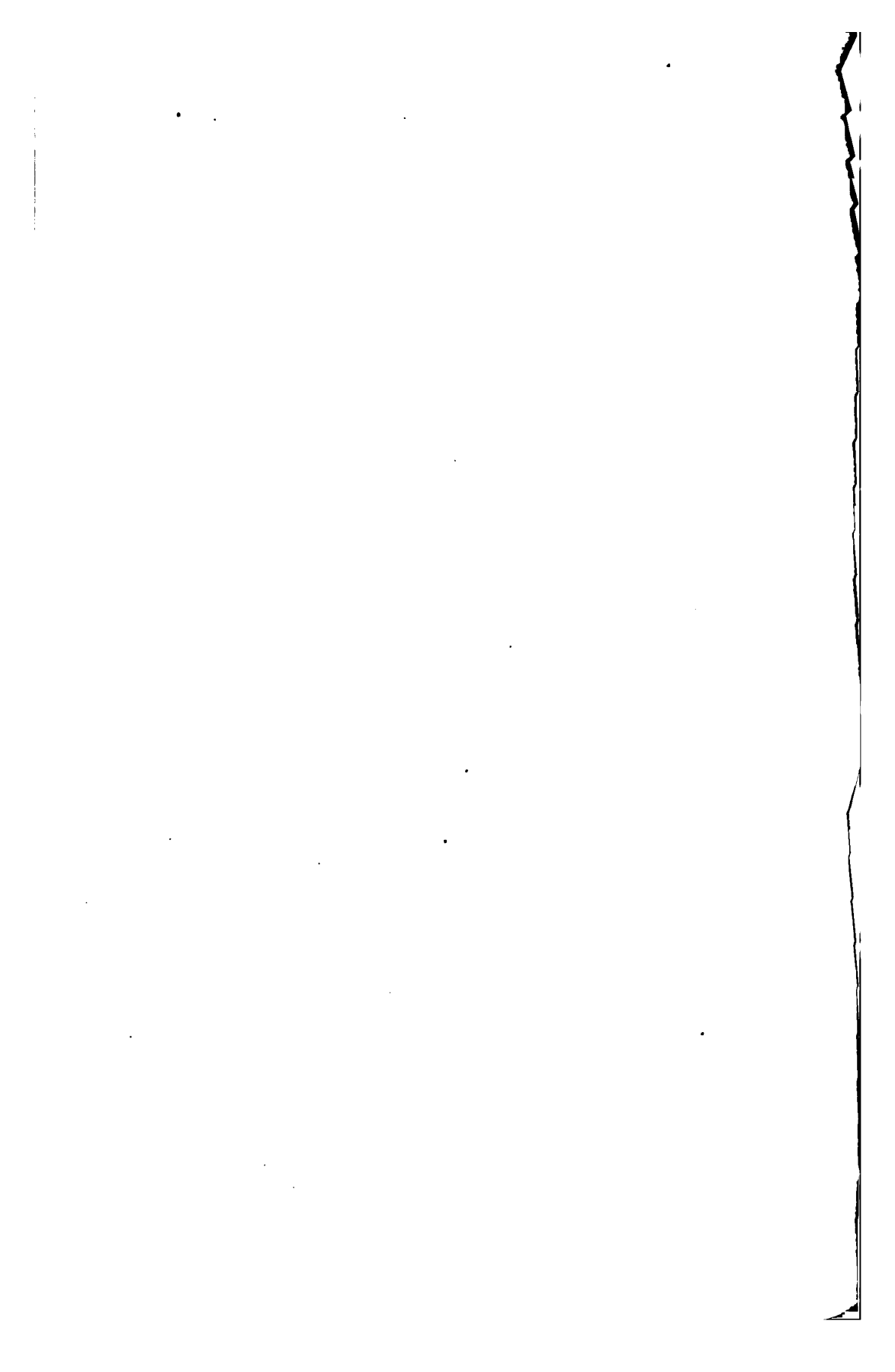

## Argument of counsel.

He never advertised it or sold it as a speech transmitter. He never offered it to any man as such. Nobody ever sought for it for the purpose of transmitting speech. He never hinted in any of his advertisements that speech was the thing to be transmitted by it, and that it would yield speech.

In every case where anybody has testified that in his own laboratory he got speech with the Reis apparatus, we have said to him by way of cross-examination, "Won't you be good enough to repeat that operation in the presence of witnesses, as was done in the Dolbear case?" And they never have done it—never complied with the demand.

Reis *hoped* to make a speaking telephone, but after he had worked for many years with no success, after he had made first one form and then another, and finally got into his hollow box form which was made by the apparatus makers and sold, he never intended *that* for speech. He never asserted it would talk.

I will show you Reis's receiver. This C is Reis's receiver. Its operation is this: That (indicating) is a coiled wire through which the current is passed or stopped, whichever it may be. That (indicating) is a knitting needle run through its centre. The ends of this needle stick out a couple of inches, and rest on the bridge pieces on the box.

This is the final box form of 1868.

When the current flows through that coil and around that core, it elongates the core a very little, and when the current stops it contracts again. Every starting and stopping of the current magnetizes and demagnetizes the needle, as an electro-magnet becomes magnetized and demagnetized by starting and stopping the current. Every time that needle becomes magnetized by the passage of the current it expands a little, and when it becomes demagnetized by the cessation of the current it contracts. That produces in the needle itself a slight vibratory motion, which is imparted to the air and produces the sound.

Here is a dummy which will show the particular working

## Argument of counsel.

parts. Here is a board A with a three-inch hole in it, over which is nailed a piece of pasteboard D to represent a diaphragm.

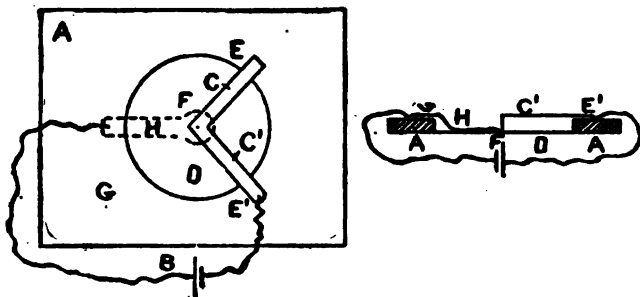

On that rests a little three-cornered piece of metal C C', the two legs of which are hinged or set in little sockets E E', in the framework A, while the middle leg of it projects over and rests—is not fastened, but just rests by its own weight—on a piece of platinum foil on the centre of the diaphragm at F: From the other side of the top at G comes a strip of platinum foil F H, which extends down over the diaphragm to its centre F, where it is glued, so that it moves with the diaphragm. The leg at the angle of the piece C C' rests on this foil at F. The electrical connections are made in such a way that the wires from the battery B come, one to that platinum foil at G, while the other is fastened at E to one leg of the three-cornered piece C C'.

There is no such thing as an “intermittent current.” You can have a succession of flows and starts, and flows and stops, and for convenience that is spoken of as an “intermittent current.”

“Undulatory current” simply means that the current is now of one strength, and at the next instant is of a different strength.

The curves do not represent waves like those of the sea. “Undulatory current,” like “intermittent current,” is merely a phrase which expresses a conception of the successive conditions of the current.

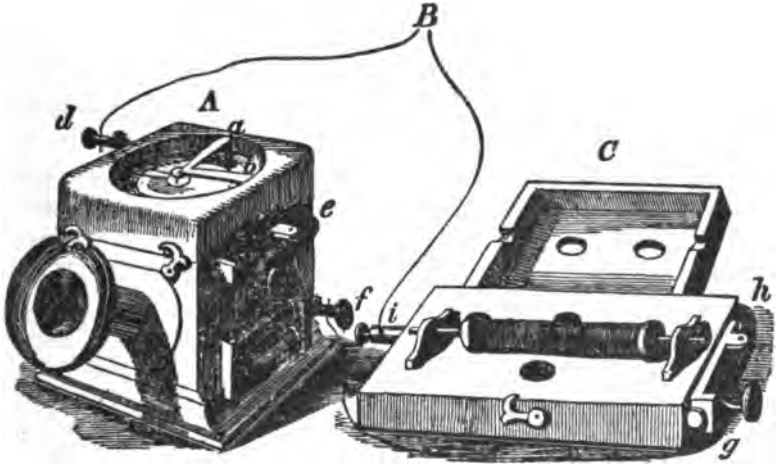





## Argument of counsel.

All sonorous vibrations are "undulatory" in their character, in the technical sense in which that word is used.

The intermittent current is represented by a series of blocks.

This does not mean that there are on the line at any one instant a succession of spurts of electricity—electricity at some parts of the line, and none at others. It means that for a period of time, represented by the length of the block, there is, all over the line, a current whose strength is represented by the height of the block; and that after that, for a period of time represented by the blank space, there is no current at all anywhere. That phenomenon is called an intermittent current.

If, now, a current varies, so that at one instant it is of a strength represented by the height of the line E, and at the next instant of a strength represented by the length of the perpendicular line F, and so on, and the variations of

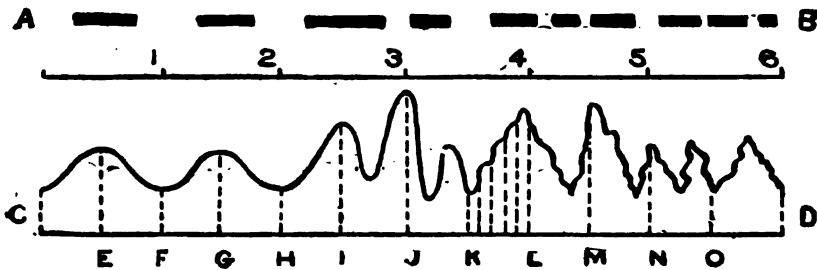

strength, or the curve which represents those variations by joining the tops of those lines, are undulatory in its character, then we speak of that current as undulatory, because of that variation in its strength at successive instants; and those are the symbols that are used in the patent.

Bell was possessed with the likeness between the current which he proposed to use and sound-waves themselves. And that is the substance of his patents; that is the cardinal key and idea of his whole patent.

Bell says in the patent: "In illustration of the method of creating electrical undulation, I shall show and describe one form of apparatus for producing the effect."

## Argument of counsel.

It is Fig. 5 of the patent which he is now describing. Here is a view of one. He puts a number of those on the circuit for a multiple telegraph, and he says when one of them, A, vibrates, it produces a note of a pitch corresponding to the length of that free arm, *c*, and it produces electrical undulations on the wire which correspond to that pitch. When another is on, it produces electrical undulations corresponding to its pitch; and those two electrical undulations going into the wire do not obliterate each other, but they manifest themselves by the composition and by the

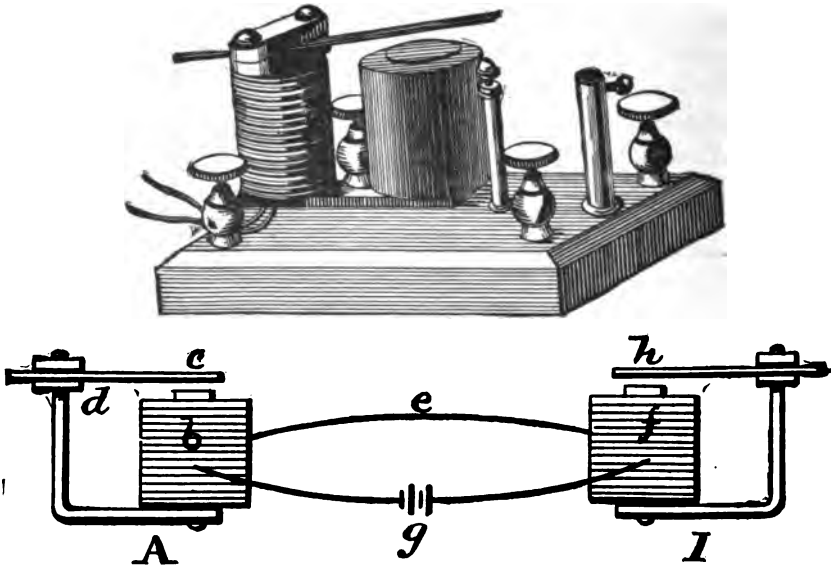

peculiar form of curve which will express the combined result of the two. It is true of harmonic multiple telegraphy that a receiving instrument can be devised, and it was well known (Bell had described it in a previous patent) which could analyze out those two sets, so that one instrument would respond to one note, or set of notes or pitches, and the other would respond to the other.

The patent says: "Hence, by these instruments two or

## Argument of counsel.

more telegraph signals or messages may be sent simultaneously over the same circuit without interfering with one another."

That is the harmonic multiple telegraph.

And the way in which that is done is described in the last four lines of the preceding paragraph: "The duration of the sound may be used to indicate the dot or dash of the Morse alphabet, and thus a telegraphic dispatch may be indicated by alternately interrupting and renewing the sound." And in that way, by those instruments (Fig. 5 of the patent), several telegraphic signals may be sent simultaneously over the same circuit without interfering with one another.

The patent proceeds to describe that these electrical undulations, generally like sound-waves, can be used for other special results, when they copy *special sound-waves*. The patent says: "I desire here to remark that there are many other uses to which these instruments may be put, such as the simultaneous transmission of musical notes, differing in loudness, as well as in pitch, and the telegraphic transmission of noises or sounds of any kind."

The first statement was that he could transmit harmonic multiple telegraph messages by variations of pitch; and he has described that. Nothing more is to be added about that. That is finished. Now he says: "I desire here to remark that there are other uses." I don't see how it would be possible to find more explicit language in which to state that what he is going to say now is not harmonic multiple telegraphy, but it is "another" use.

He goes on and describes: "When the armature *c*, Fig. 5, is set in vibration, the armature *h* responds not only in pitch, but in loudness."

When the armature *c* of one of these instruments is set in vibration, the armature *h* of the corresponding instrument just like it at the other end responds, not only in pitch but in loudness. Thus, when this armature *c* vibrates with little amplitude, a soft sound will proceed from the corresponding

## Argument of counsel.

armature *h* of the corresponding instrument. When this armature *c* vibrates violently, a violent sound will be produced by the armature *h* of the transmitter corresponding to it at the other end.

The patent continues: "The armature *c*, Fig. 7, is fastened loosely by one extremity to the uncovered leg, *d*, of the electro-magnet, *b*, and its other extremity is attached to the centre of a stretched membrane, *a*. A cone, *A*, is used to converge sound vibrations upon the membrane. When a sound is uttered in the cone, the membrane, *a*, is set in vibration, the armature *c* is forced to partake of the motion." That necessarily follows: "and thus electrical undulations are created upon the circuit, *E*, *b*, *c*, *f*, *g*."

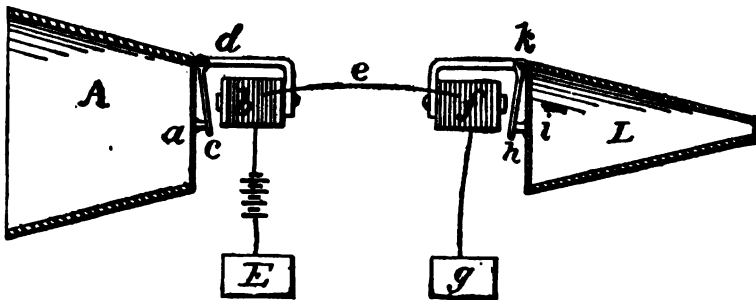

These undulations in this case, where they are caused by the voice, are stated by the patent to be "similar in form to the air vibrations caused by the sound; that is, they are represented graphically by similar curves."

When you speak, when you make any sound in there, the sound-waves vibrate the diaphragm of this instrument, and this armature takes up those vibrations and copies them because it is fastened to the diaphragm. These motions of the armature produce electrical undulations in the circuit; not only undulations, but undulations *similar in form* to the motions of the diaphragm and attached armature; and those undulations when they reach the other end, by reason of their similarity in form, influence that armature *h* of the receiver to copy the movements of this transmitter armature *c*. What

## Argument of counsel.

is the result? A similar sound to that uttered in there at A is heard to come out here at L, as claimed by Bell in the 5th claim.

The patentee describes in claim 3 that you may produce the undulations by the inductive mode; next, in claim 4, that you may produce the undulations by the variable resistance mode; and finally we come to claim 5. That is not a claim for producing undulations; it is, as my brother Lowrey very well stated, and he has got it in his brief, for transmitting speech by means of them, when they are of the particular form specified.

The second Bell patent, No. 186,787, of January 30, 1877, is for mere improvements in the mechanical details of Fig. 7, of the same patent, without altering the nature of the operation in any way.

Mr. Bell subsequently found that instead of employing a battery to magnetize those cores, as the first instrument did, he could employ a permanent magnet.

He made such an instrument in July, 1876, and in the fall of 1876 he talked from Boston to Cambridge, without any battery, by means of a permanent magnet. That is one of the improvements that is contained in this second patent.

*Fig. 5.*

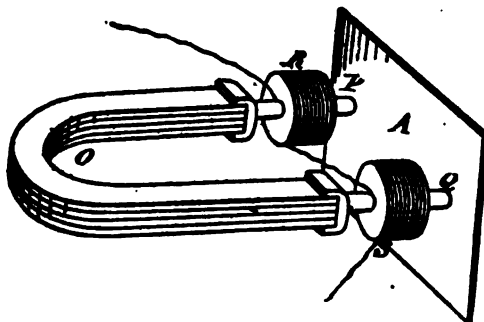

The drawing shows a horseshoe permanent magnet with a soft-iron core fastened to each end or pole, and a short, large coil of wire wound around that core.

## Argument of counsel.

Those soft-iron cores, being screwed into the ends of this permanent steel magnet, become themselves, for the time being, magnetic. We therefore have these cores magnetized without the expense and trouble of a battery. There is no change in the principle, but this particular contrivance was found cheaper and better than the form of the first patent.

There was a third improvement.

This instrument marked "Fig. 2" of Bell's second patent consists of a box. At the front end of it there is an iron diaphragm A. Behind this is the electro-magnet consisting of the bar or core F, surrounded by the coil G. There is a little difference of form, which I will explain by and by. There are two forms. In front of the diaphragm A you see a space of about two inches up and down, a white space about a quarter of an inch wide, an air space, an air chamber. In front of the diaphragm and from the centre of that space a tube E comes out.

*Fig. 2.*

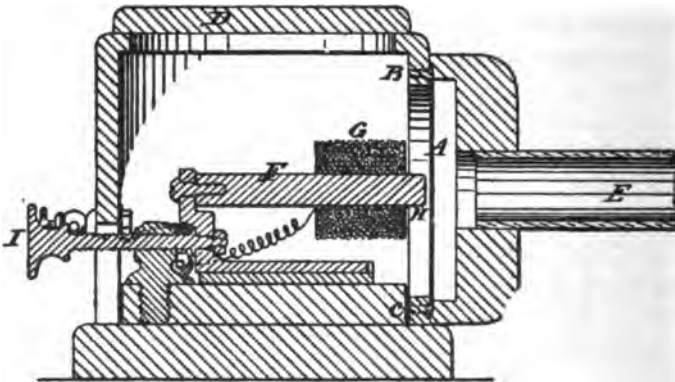

The wood behind this diaphragm is hollowed out so as to make a cavity about two inches in diameter and about one-eighth or one-sixteenth of an inch in thickness, so that there is an air chamber behind—rather I should say in front of—

## Argument of counsel.

that diaphragm. The air chamber communicates with the exterior air by a central opening through the tube E.

Bell found that that particular form of mouthpiece—a narrow air space in front of the diaphragm communicating with the external air by a circular opening at the centre—is the best form, both for speaking and for listening at. It gives less reverberation and communicates the sound better than any other.

The commercial instruments have always taken that shape, very pronounced in these instruments.

The speaking-tube was a convenience for these instruments.

## BELL'S EARLY INSTRUMENTS.

We know now why Bell did not obtain better results in June and July, 1875. All the important parts of the pair of telephones then used remain, and the apparatus has been reconstructed in exact accordance with them. The reconstructions cannot differ from the originals, unless in mere workmanship. In 1879, the reconstructed instruments were taken by a number of witnesses to the precise place in the noisy workshop where Bell tried the originals in 1875, and no words could be made out. They were immediately taken to a quiet place, and conversation was carried on with them.

In the Drawbaugh case two sets of them were made in scrupulous accord with the originals, and, in a quiet place, newspaper paragraphs were read through them in the presence of the defendants' counsel and expert witnesses.

The following are views and sections of the instruments:

## INTRODUCTION OF THE ELECTRIC SPEAKING TELEPHONE TO THE PUBLIC.

Bell's patent, No. 174,465, was applied for February 14, 1876, and granted March 7, 1876. His first public exhibition of his apparatus was made before the American Academy of Arts and Sciences at Boston, May 10, 1876, and published in their proceedings. Sets of his apparatus, shown

## Argument of counsel.

in view and in section in the following cuts, were exhibited at the Centennial Exhibition, in June, 1876:

The particular instruments actually used were the "membrane telephones" as transmitters, and the "membrane telephone" and "iron box magnet receiver" as receivers.

The first instrument that was put out for commercial use in 1877 (see p. 383.)

It was convenient in that to have a tube, because it was a heavy instrument, and you could not get your mouth to it very closely. When you come to a hand instrument, there is no longer any need of that tube, because the instrument itself can be applied to the mouth or ear.

If you will look at the inside of the mouthpiece, the cap piece that unscrews and takes off, you will see a little ledge about a sixteenth of an inch long, running around near the edge on the hard rubber. Take the other piece, the small piece you have in your hand, the cap piece you have just unscrewed, and see the ledge running around inside there near the edge. Now, if you put this black diaphragm on there you have got a little air space below the diaphragm, the size of which is the diameter of that inside space, and the depth of which is the height of that little ledge.

Those two diagrams are "the Bell telephone as usually made with a microphone transmitter," and "the Bell telephone as used by Dolbear."

The above is the Bell telephone as usually made with a microphone transmitter, (p. 385.)

In the last diagram, T is the microphone, B the battery connected with a wire which forms the inside helix of the induction coil IC. The outside helix of the induction-coil goes to line and to the distant station.

The claims of Dolbear's patent are mere claims for mechanical construction, details of construction, particularly in rearranging the plates of an old condenser receiver, so as to vibrate more powerfully, and do a little better than they had done before.



**NOS. 49 AND 60, BELL'S FIRST TELEPHONE OF 1875.**

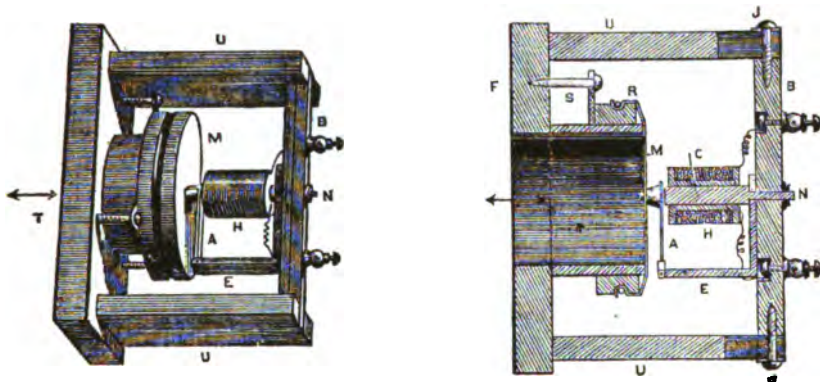

Scale of Section, one fourth of original.

**NOS. 51 AND 52, BELL'S SECOND TELEPHONE OF 1875.**

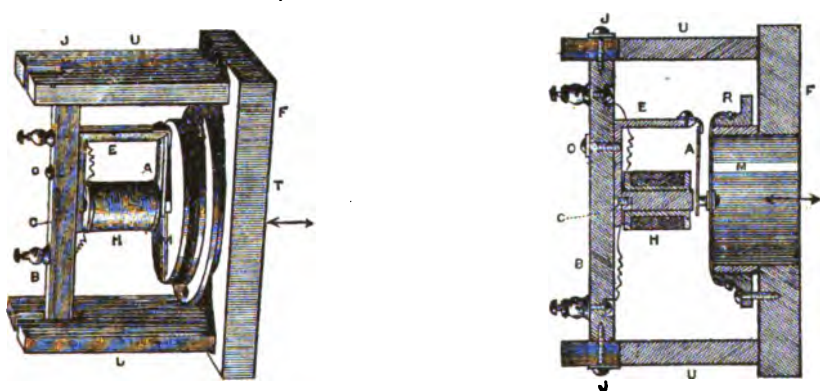

Scale of Section, one fourth of original

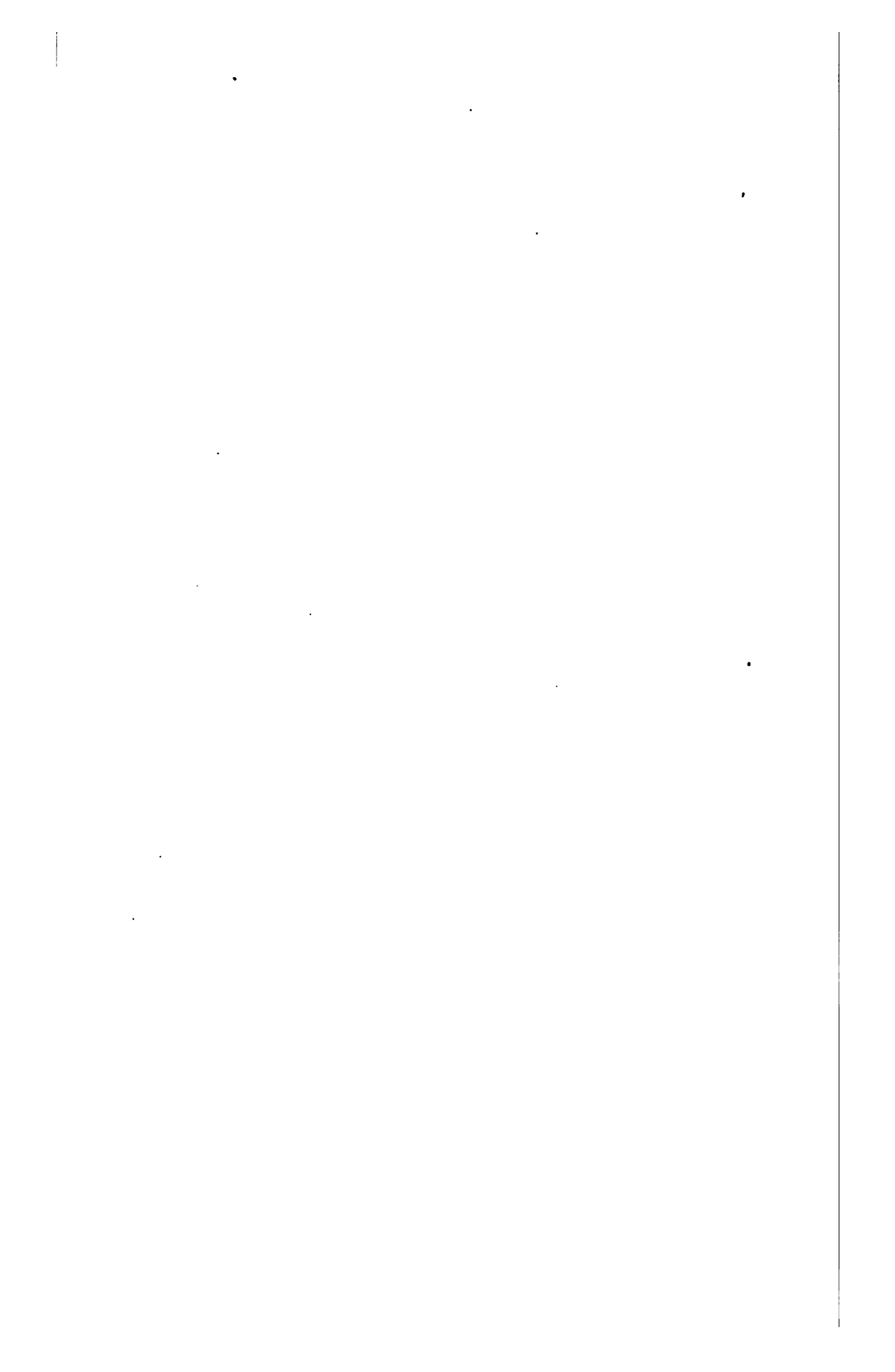

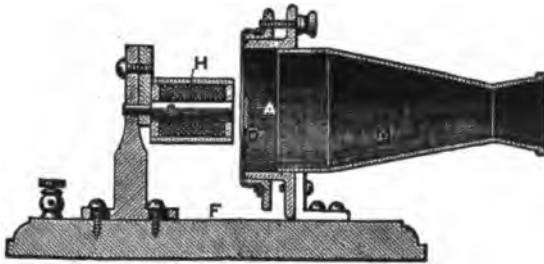

BELL'S CENTENNIAL SINGLE POLE MEMBRANE TELEPHONE.—VIEW AND SECTION.



BELL'S CENTENNIAL DOUBLE POLE MEMBRANE TELEPHONE.  
(Same size as the single pole telephone.)

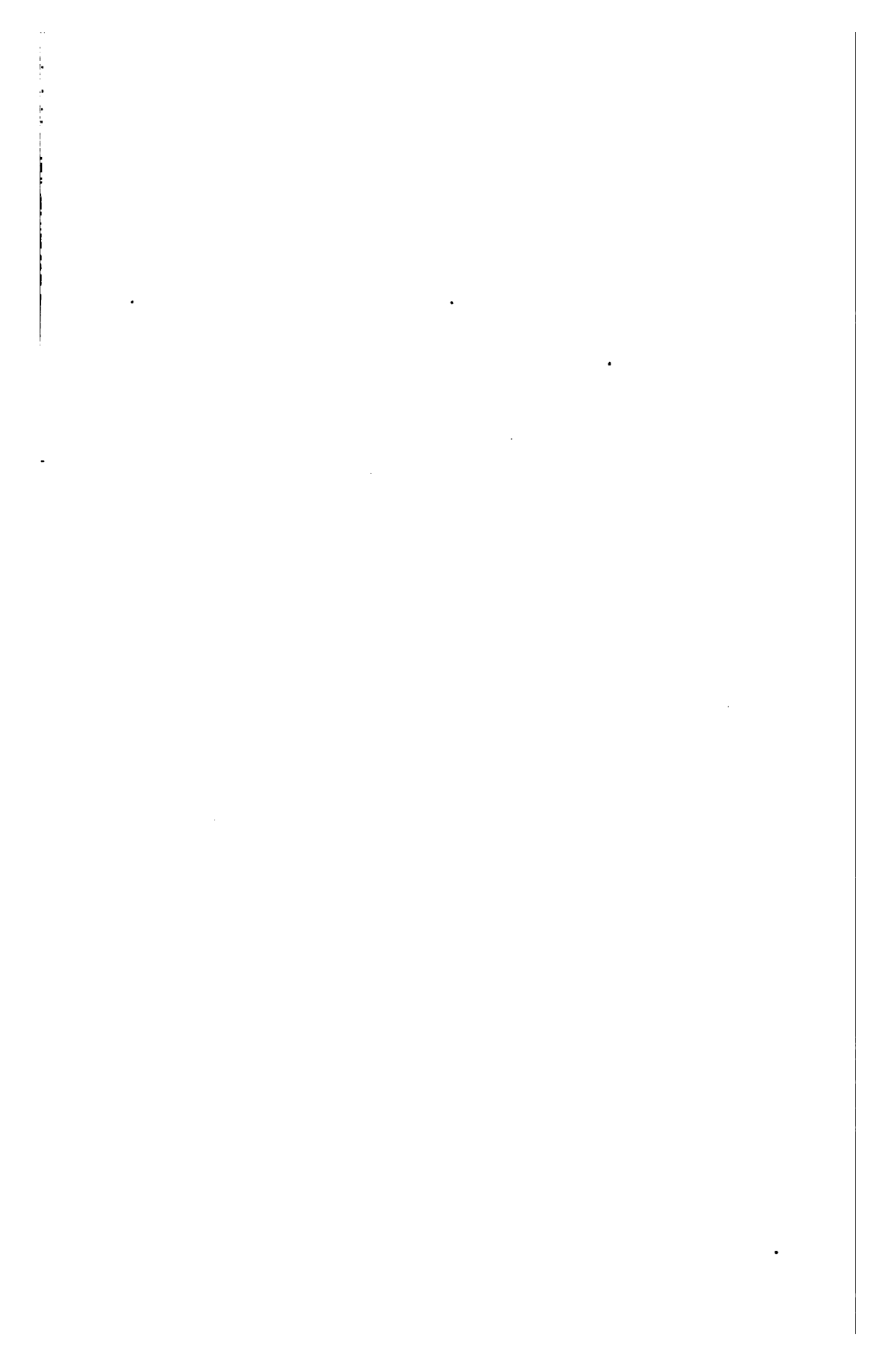

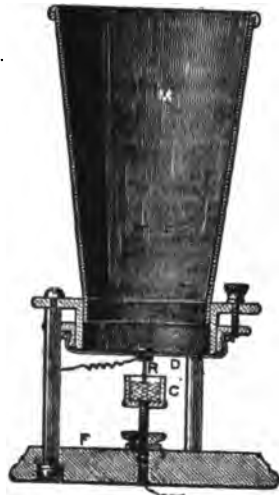

**BELL'S CENTENNIAL LIQUID TRANSMITTER.**

16

**MR. BELL'S CENTENNIAL EXHIBITION.**

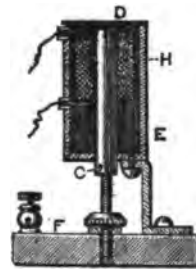

**BELL'S CENTENNIAL IRON BOX MAGNET RECEIVER.**

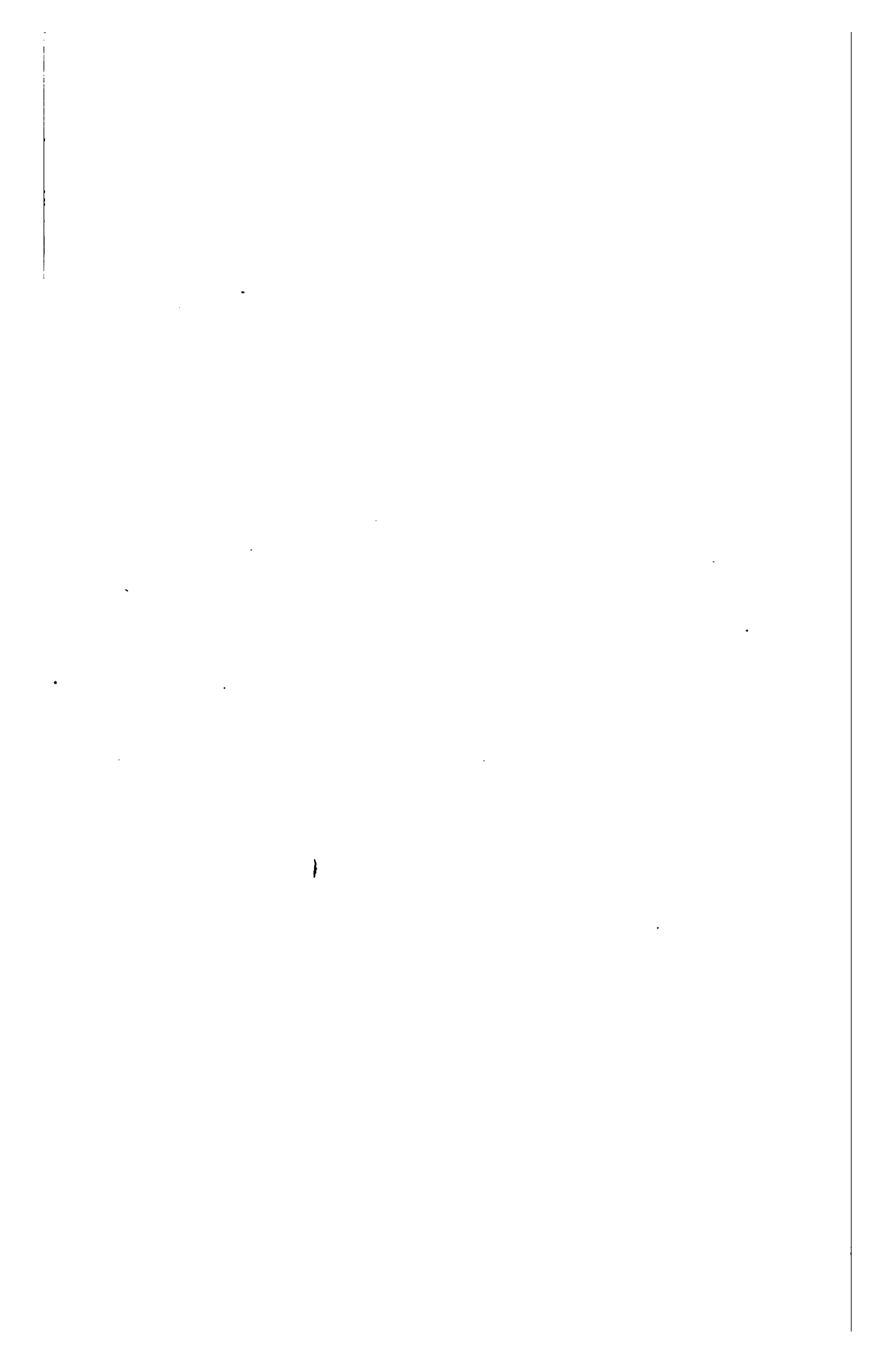

**EARLY FORMS OF MAGNETO TELEPHONES PUT INTO COMMERCIAL USE BY MR. BELL.**



**BOX TELEPHONE, IN USE BEFORE APRIL 5, 1877 (COVER REMOVED).**

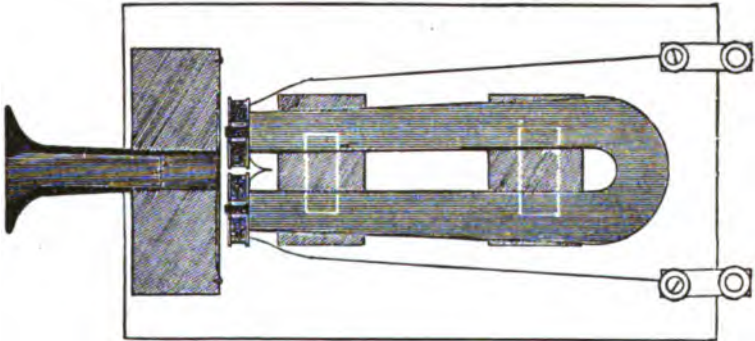

**BOX TELEPHONE, IN COMMERCIAL USE IN JUNE, 1877 (COVER REMOVED).**

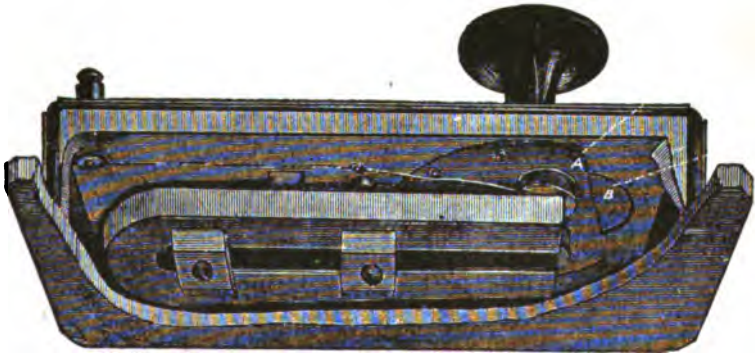

**BOX TELEPHONE, IN COMMERCIAL USE IN AUGUST, 1877 (PART OF BOX OF DIAPHRAGM CUT AWAY), FASTENED TO THE WALL IN AN UPRIGHT POSITION.**





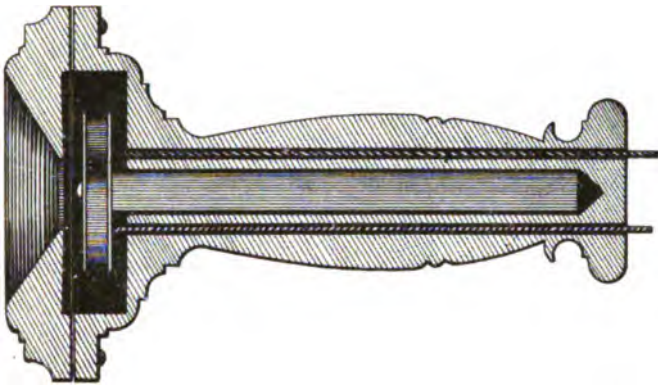

**HAND TELEPHONE IN USE AUGUST, 1877.**

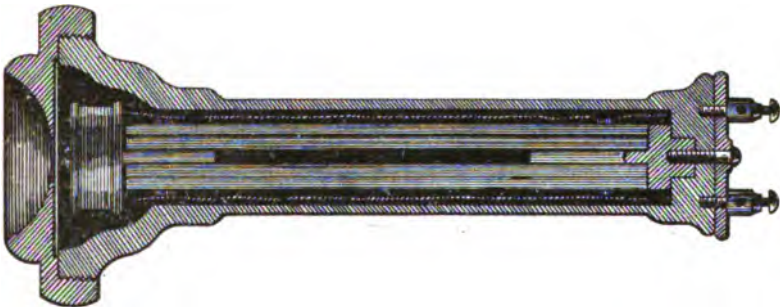

**HAND TELEPHONE IN USE SINCE DECEMBER, 1877.**

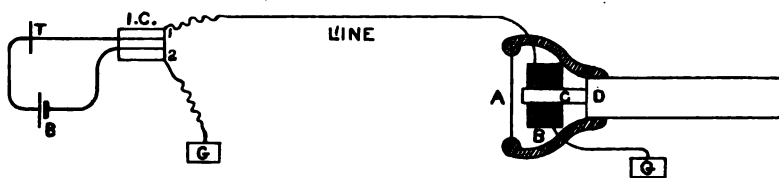

**THE BELL TELEPHONE AS COMMERCIALY USED.**

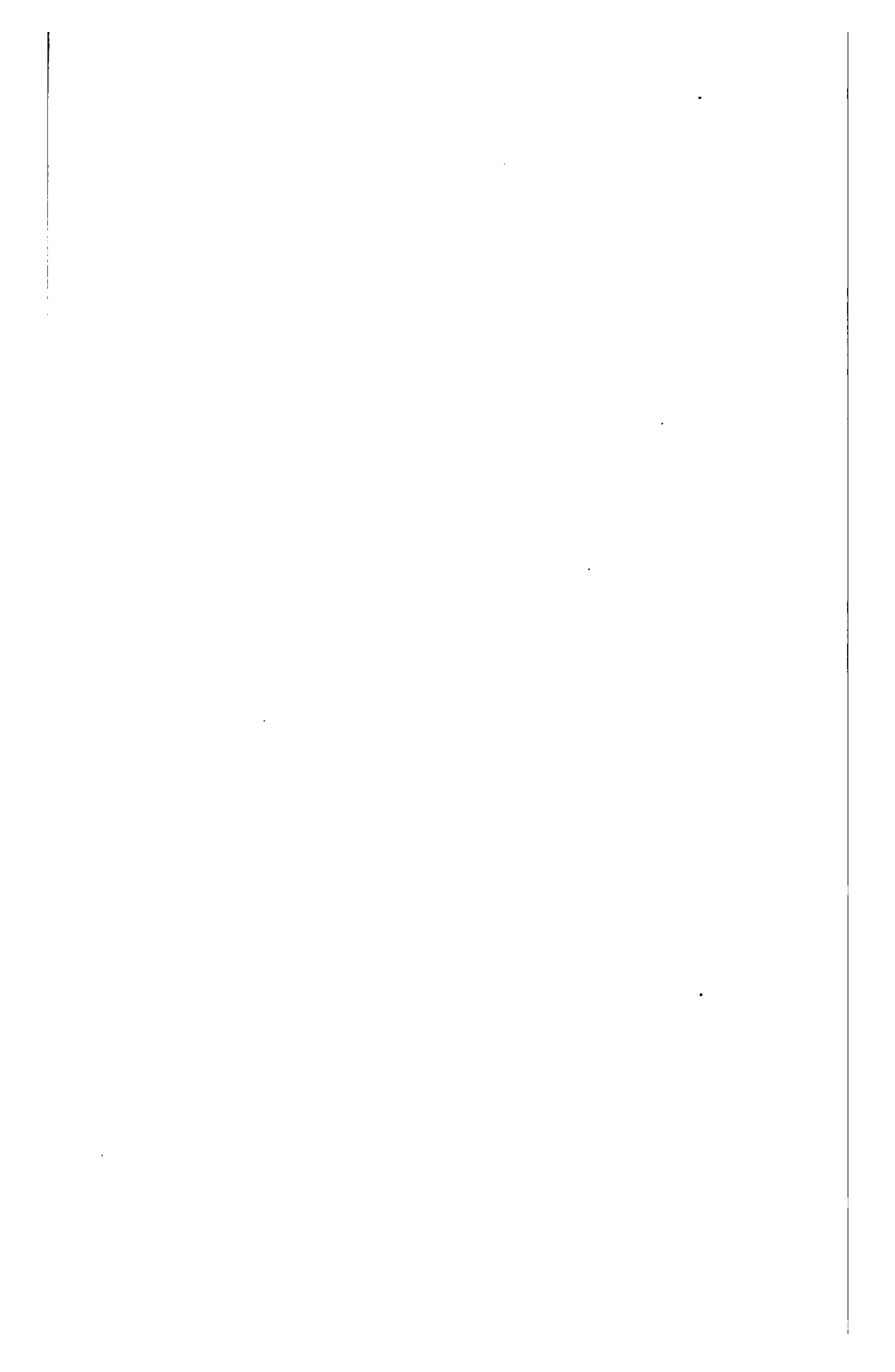

## Argument of counsel.

What makes the Dolbear to be a speaking telephone is not what he invented. It is not what he got from Reis. It is what he got from Bell.

The various defendants allege, in their answers, that the speaking telephone had been described, and the art of transmitting speech by electricity fully disclosed, in more than ninety patents and printed publications, before the Bell patent—many of them a dozen years before.

Yet it is a part of the personal experience of every member of this Court, and is a fact in the history of our times, which is undisputed, that speaking telephones were unknown before 1876.

There is not a pretense that any man ever applied to any useful purpose any of the contrivances which are now alleged to have been speech transmitters.

Yet the public were so ready for the speaking telephone that ten years of Bell's patent have put more than half a million of them into use.

The Reis instruments were well known as instruments which could *not* transmit speech, and the Reis publications never taught any one how to make an instrument that could. Bell's invention is brought within the authorities on the subject.

*Howe v. Underwood*, 1 Fish. Pat. Cas. 162; *Howe v. Morton*, Id. 594; *Penn v. Bibby*, L. R. 2 Ch. App. Cas. 127; *Tilghman v. Proctor*, 102 U. S. 708 [13 Am. & Eng. 29].

The method, and not the form of the apparatus which embodied it, constituted the substance of the invention.

In *Bischoff v. Wethered*, 9 Wall. 815 [8 Am. & Eng. 213], this Court, by Mr. Justice BRADLEY, said: "The whole subject matter of a patent is an embodied condition."

In *Winans v. Denmead*, 15 How. 330 [6 Am. & Eng. 107] (CURTIS, J.), it is said that the inventor before the Court might justly assert: "My improvement did not consist in a change of form, but in the employment of principles or powers in a new mode of operation, embodied in a form by

## Argument of counsel.

means of which a new or better result is produced; it was this which constituted my invention."

*The rule of law about Prior Publications.* That the Reis publications were known for many years without leading to the use of speaking telephones, in the case of a machine so much wanted that the public took it at once the instant Bell offered it, is a proof from experience that the publications were not sufficient under the rule of law.

*Seymour v. Osborne*, 11 Wall. 516 [8 Am. & Eng. 290]; *Cohn v. U. S. Corset Co.* 93 U. S. 366 [10 Am. & Eng. 473]; *Cahill v. Brown*, 15 Off. Gaz. 697; *Atlantic Giant Powder Co. v. Parker*, 16 Off. Gaz. 495; *Hood v. Boston Car-Spring Co.* 21 Fed. Rep. 67; *Betts v. Menzies*, 10 H. L. Cas. 154; *S. C. Goodeve's Pat. Cas.* 51; *Nelson v. Betts*, L. R. 5 H. L. 15; *S. C. Goodeve's Pat. Cas.* 56.

Can any swearing of professional experts now make this Court believe that the Reis was a speaking telephone? Such testimony, and the men who give it, have been characterized by the Courts.

*Nelson v. Betts*, *supra*.

In *McCormick v. Talcott*, 20 How. 409 [6 Am. & Eng. 410] this Court spoke of such depositions as "The opinions (the reveries they may often be called) of a class of men styled experts; men as often skilful and effective in producing obscurity and error as in the elucidation of truth."

It would not be material if, to-day, by applying to Reis' contrivance the knowledge disclosed by Bell and his successors, making it perform a new operation and cause the undulations of the Bell patent, it would produce the new result of the Bell patent.

*Morris v. McMillin*, 112 U. S. 248 [15 Am. & Eng. 310]; *Pennsylvania R. Co. v. Locomotive E. S. Truck Co.* 110 U. S. 490 [15 Am. & Eng. 148]; *Blake v. San Francisco*, 113 U. S. 682 [15 Am. & Eng. 535]; *Consolidated S. Valve Co. v. Crosby S. G. & Valve Co.* Id. 170 [15 Am. & Eng. 460]; *Clough v. Barker*, 106 U. S. 176 [14 Am. & Eng. 166].

## Argument of counsel.

In *Smith v. Nichols*, 21 Wall. 118 [9 Am. & Eng. 425], it is said "A patentable invention is a mental result."

*Winans v. Denmead*, 15 How. 330 [6 Am. & Eng. 107].

Criticisms on the form of the patent are simply attempts to pick a flaw in Bell's paper title to that which he has earned. They are attempts to recall the grant on behalf of that community which has received and enjoyed the consideration he gave for it. The Courts have often expressed their views on this subject.

*Howe v. Underwood*, 1 Fish. Pat. Cas. 162; *Grant v. Raymond*, 6 Pet. 218 [4 Am. & Eng. 245]; *Hinks v. Safety Lighting Co.* L. R. 4 Ch. Div. 607; *S. C. Goodeve's Pat. Cas.* 254; *United Telephone Co. v. Harrison*, *Goodeve's Pat. Cas.* 484.

The Patent Office found at the time that the language of the Bell patent was intelligible, and conveyed some definite idea. This, we submit, is conclusive on that question.

It is in accordance with all the rules of law, that an objection is considered of no avail, if not taken when it could be corrected.

*Roemer v. Simon*, 95 U. S. 220 [11 Am. & Eng. 348], *Webster Loom Co. v. Higgins*, 105 U. S. 596 [14 Am. & Eng. 70].

The description is sufficient in law in the patent.

*Pickering v. McCullough*, 104 U. S. 318 [13 Am. & Eng. 238]; *Webster Loom Co. v. Higgins*, 105 U. S. 586 [14 Am. & Eng. 70]; *Gibson v. Harris*, 1 Blatch. 171.

The presentation of such a patent proves in law a completed invention from the date of filing.

*Dane v. Chicago Mfg. Co.* 2 Off. Gaz. 677; *S. C.* 3 Biss. 380; *S. C.* 6 Fish. Pat. Cas. 130; *Wing v. Richardson*, 2 Cliff. 449; *S. C.* 2 Fish. Pat. Cas. 535; *Wheeler v. Chipper M. & R. Co.* 6 Fish. Pat. Cas. 1; *S. C.* 10 Blatch. 181; *Johnsen v. Fassman*, 1 Woods, 138; *Kelleher v. Darling*, 4 Cliff. 426.

A specification prepared, executed, shown to others, promptly filed, and resulting in a patent, carries the invention back to its date of execution.

## Argument of counsel.

*Webster Loom Co. v. Higgins*, 105 U. S. 594 [14 Am. & Eng. 70]; *Colgate v. Western U. Tel. Co.* 15 Blatch. 365; *Colgate v. Gold & S. Tel. Co.* 16 Blatch. 505.

What constitutes infringement and how to ascertain it, has never been stated better, or with more freedom from confusing refinements, than in the *Sewing Machine Case*.

*Howe v. Morton*, 1 Fish. Pat. Cas. 588.

Bell first accomplished a great result, entirely new in kind, by the use of a means entirely new in kind.

*Tilghman v. Proctor*, 102 U. S. 708 [13 Am. & Eng. 29]; *Corning v. Burden*, 15 How. 267 [6 Am. & Eng. 69].

It is well settled that if the experiments do not result in a useful machine, particular features of it "cannot be dug up in after years and produced to defeat the patent of an independent and successful inventor."

*Aultman v. Holley*, 6 Fish. Pat. Cas. 534; 11 Blatch. 317 (WOODRUFF, J.); *Whiteley v. Swayne*, 7 Wall. 685 [8 Am. & Eng. 70]; *Johnson v. Root*, 1 Fish. Pat. Cas. 366 (SPRAGUE, J.) Same case on a second trial, 2 Cliff. 643 (CLIFFORD, J.)

Mr. WILLIAM W. KER, for the Clay Commercial Telephone Company:

It is alleged in the complaint that the American Bell Telephone is "a corporation duly established under the laws of the Commonwealth of Massachusetts." This is a descriptive allegation, not proved as laid, which is a fatal variance.

2 Greenl. Ev. 82, § 64.

The name of the proposed corporation is not mentioned in the body of the Act. "When a corporation is erected, a name must be given to it, and by that name alone it must sue and be sued, and do all legal acts."

1 Bl. Com. chap. 18, p. 476; *Ang. & Ames, Corp.* 10th ed. § 1; *Dartmouth College v. Woodward*, 4 Wheat. 636.

The title cannot confer the name American Bell Telephone Company upon the corporation. "The title of a statute, it has been repeatedly held, is no part or parcel of the statute."

## Argument of counsel.

Potter's Dwarr. Stat. & Const. 102; Sedg. Const. Stat. 2d ed. 39, 40; Mills v. Wilkins, 6 Mod. 62; Hadden v. Barney, 5 Wall. 107; Commonwealth v. Slifer, 53 Pa. 71; Union Pass. R. Co's. Appeal, 81\* Pa. 94.

The special Act does not give the persons named in it power to assume a name. It gives them power to *organize* a corporation. The Act is to be taken most beneficially for the sovereign, and against the grantee.

2 Bl. Com. 347; Potter's Dwarr. Stat. 146, 215; Dartmouth College v. Woodward, *supra*; Commonwealth v. Erie & N. E. R. Co. 27 Pa. 351.

The special Act refers to chapter 224, by enacting that Bell and his associates might "organize a corporation according to the provisions of chapter 224." The powers conferred by the special Act are limited to the precise language used. The language confers no authority upon the Secretary of the Commonwealth to issue such a certificate as has been offered in evidence.

Commonwealth v. Central Pass. R. Co. 52 Pa. 520; Bowling Green & M. R. Co. v. Warren County Court, 10 Bush. 711; Ellis v. Paige, 1 Pick. 43; Farmers' L. & Trust Co. v. Carroll, 5 Barb. 613; Ang. & Ames, Corp. §§ 81, 111.

The Bell Telephone Company of Philadelphia, is one of the complainants mentioned in the bill of complaint. No Act, law, charter, or evidence was offered to prove that such a corporation ever did exist.

The assignment from the Bell Telephone Company recites other agreements that are a part of the chain of title. The counsel for defendants objected to the reception of the evidence, and, as a part of the objection, called for the agreements mentioned in the assignment. The evidence should have been produced with the agreements mentioned therein, and proper proof made of the execution thereof.

The Bell Telephone Company is alleged to have been incorporated under the laws of Massachusetts "to carry on business for the whole United States outside of New England,"

## Argument of counsel.

and was thus prohibited from carrying on business in Massachusetts, under whose laws it was incorporated. Therefore, the company should be regarded not as a corporation, but merely as a partnership.

“No rule of comity will allow one State to spawn corporations and send them forth in other States to be nurtured and do business there, when said first-mentioned State will not allow them to do business within its own boundaries.”

*Land Grant R. & Trust Co. v. Coffee County*, 6 Kan. 245; *Hill v. Beach*, 12 N. J. Eq. 31.

This judgment and decree are erroneous, because the complainants' proofs show that the American Bell Telephone Company owned but two-thirds of the patent dated March 7, 1876, and but one-third of the patent dated January 30, 1877.

The evidence shows that Bell was not the original and first inventor of the inventions described in the patent. His apparatus is inherently unfit for telephonic purposes in the transmission of articulate speech.

The Court below erred in entering a decree against the appellants, Scott and others, who were officers or directors of the Clay Commercial Telephone Company, and not jointly carrying on the business of telephony.

The Court below erred in entering a decree against the appellant, Henry Clay, who had conveyed to the Clay Commercial Telephone Company the letters patent that had been granted to him, and had no further interest in the patents.

The bill of complaint is defective for want of sufficient parties.

The complainants failed to prove the material allegations set forth in the bill of complaint.

Bell's letters patent are not good and valid in law.

The evidence shows that the instruments used by the Clay Commercial Telephone Company are not arranged or constructed according to the specifications and claims set forth in the Bell patents; and that the defendants had not infringed said patents.



## Argument of counsel.

Messrs. LYSANDER HILL, GEORGE F. EDMUNDS, DON M. DICKINSON, T. S. E. DIXON, CHARLES P. CROSBY, H. C. ANDREWS and MELVILLE CHURCH, for the People's Telephone Company (the Drawbaugh case) and the Overland Telephone Company :

It is conceded that the machines conceived and constructed by Daniel Drawbaugh, which did transmit articulate speech, operated on the principle which has been applied under the Bell patents.

The principle is that of transmitting articulate speech upon wires by a continuous electric current, with the addition of means to cause incidental undulations of the current corresponding with the incidental tones of the human voice.

When applied in the electric speaking telephone the practical result is, that the same air vibrations set in motion by the human voice, and producing sound by their impact upon the tympanum of the ear, are repeated with comparative exactness upon the tympanum or diaphragm of the transmitting instrument, are then by a process carried to a distance, and there with equal exactness repeated upon the tympanum or diaphragm of the receiver, and thence again repeated upon the tympanum of the listening ear.

The issue is simply, Did Alexander Graham Bell or Daniel Drawbaugh first conceive and apply this principle, and clothe the conception in substantial forms which demonstrated at once its practical efficacy and utility?

This Court has clearly laid down the lines within which legal evidence can solve the question in favor of Drawbaugh.

*Gaylor v. Wilder*, 10 How. 477 [5 Am. & Eng. 188]; *Coffin v. Ogden*, 18 Wall. 120 [9 Am. & Eng. 125].

When the Drawbaugh defence is tested by these cases, no attack can reach it.

The policy of the law is to give the utmost possible encouragement and protection to the inventor, not to the patentee.

The vast amounts invested under the Bell patents and in

## Argument of counsel.

perfecting them, the hosts of people who have their "all" invested, the reflections upon "unscrupulous speculators," said to be behind Drawbaugh, cannot add a feather in weighing the matter of priority of invention.

The date of Bell's alleged invention can be fixed no earlier than March 10, 1876; certainly no earlier than February 14, 1876.

But for the purposes of the Drawbaugh defence, we may safely set the date of the conception by Bell at June 2, 1875.

Previous to this he had abandoned experiments with the diaphragm, and it was not until December 28, 1875, in his interview with Mr. George Brown, of Toronto, Canada, that he drew a sketch of his July, 1875, instrument, predicated upon his experiments subsequent to June 2, 1875, and placed upon it these words in his own handwriting: "*First attempt to transmit the human voice.*"

And so, though the evidence permits us to place it later, we fix the earliest date of Bell's invention, June 2, 1875.

We present a history from the first idea conceived by Drawbaugh, of transmitting articulate speech over a telegraph wire in 1859-60, through various experiments by which the conception finally took on mechanical, though rude forms, and became of practical use, down to the finished and nicely-adjusted mechanism; all prior to the date of Bell's invention.

This history rests for its general truthfulness, and for the accuracy of its details, upon the direct and positive testimony of an entire community, and of visitors to that community, representing all classes.

*Over two hundred persons testify to knowledge of Drawbaugh's telephones as an accomplished invention prior to the date of Bell's. Over seventy talked through the machine. Over one hundred and thirty saw the machines, and most of these identify instruments.*

Drawbaugh's shop was a common resort for people, and a place to which visitors were frequently taken; while Draw-

## Argument of counsel.

baugh himself was considered a remarkable man among the people.

The great mass of evidence for the defence is not of illiterate or careless witnesses, but on the contrary is that kind which is admitted to be even superior to that of the mere learned or scientific. There is no room for mistake.

So strong and vigorous was this class of testimony that the Court below was constrained to hold that "The case made by these witnesses is sufficiently formidable to overcome the legal presumption of the validity of the complainant's patent."

It is doubtless true that strong circumstantial should sometimes overcome direct evidence, as in *Howe v. Underwood*, 1 Fish. Pat. Cas. 162.

But the testimony here is far beyond the range of that doctrine. Other rules apply.

In this case we have hundreds of witnesses, each describing either the knowledge of his own senses of a result, or of the hearing of the result, which, if in fact it occurred, or if in fact he heard of it, was the most startling and unheard of thing in all his experience.

It was not merely a wonderful mechanical contrivance, but here was an unseen and mysterious cause, whose processes were not discoverable to the vision, whose force seemed rather of the unnatural, and whose *results alone* impressed the mind and memory.

If the machine *talked*, and the witness *heard* it, there can be no doubt of the accuracy of the impression made.

It is the strongest possible corroboration that the witnesses do not agree in their memories of the, to them, novel parts of the instrument; or are at fault or are mistaken as to the identity of the instruments, or of the difference between the carbon or variable-resistance machines and the magneto machines.

They are agreed in memory of the great, conclusive fact, **THAT THIS MACHINE DID TALK.**

## Argument of counsel

We find repeated and constantly appearing support of the main facts testified to, in perfectly natural and consistent collateral matters.

We find the unlearned and unskilled remembering well the talking machine, when clothed in the familiar garb of a tin mustard box or common glass tumbler, and forgetting other details; we find others remembering the instruments with any peculiarity about them like the spiral magnet better than they can recall other parts; we find the blacksmith remembering the shape and position of the permanent magnet with which he is familiar, and forgetting all about the electro-magnet, of which he knew nothing. We find a farmer, recalling all the details for applying electricity about the machines, but cease to wonder at his accuracy when we find that he had at some time before greatly interested himself about practical electrical machinery. The very diversity of detail, the absence of concurrence in circumstance, in occasion and in time, presents this mass of testimony impregnable against the complainants' theory, that it is the product of consultation or of prearrangement.

Care has been taken, in summoning witnesses to testify; to call no man whose character or whose word could be successfully impeached by any methods known to the law.

The charges of conspiracy and of gullibility against these witnesses rest only upon the bare statements of counsel. The lives of all the witnesses are clean, their characters for truth and veracity unassailed.

We submit an analysis of the testimony, and call particular attention to the absolute certainty of the dates as fixed by collateral matters in every instance.

Complainants have introduced forty-eight witnesses to show that they never saw the machines and *never heard them spoken of*. Of these but ten stand the test of cross-examination and rebuttal. Among these are Theophilus Weaver, who had been employed by the complainants to get up testimony, and was not on good terms with Drawbaugh, and

## Argument of counsel.

David A. Hauck, with whom Drawbaugh had a suit, and who was adjudged, both by the Examiner of Interferences, and, subsequently upon appeal, by the Board of Chief Examiners, to have sworn falsely.

This case affords striking illustration of the wisdom of those settled legal rules for valuing evidence, which give great weight to positive and little weight to negative testimony.

This Court said in *Stitt v. Huidekoper*, 17 Wall. 384: "It is a rule that ordinarily a witness who testifies to an affirmative, is to be preferred to one who testifies to a negative."

See also *Collection of Cases*, 14 U. S. Dig. 642; *Gilb. Ev.* 140; 1 *Stark. Ev.* § 32.

While no person possessing a memory could well forget having talked through one of these machines, yet it may be true, that others who testify that they never heard of it, or did not see it, tell the truth, from lack of opportunity to see or hear it.

The difference in the ability of persons to recall facts is a matter of common observation; and witnesses may be influenced not to remember.

(Counsel here commented on the testimony of complainants' witnesses.)

Negative witnesses cannot stand against the positive testimony of men who saw and talked through the telephone, remember the words, and identify the instruments.

It would be presumable that the three or four witnesses testifying that Drawbaugh did *not* speak to them were omitted to be spoken to by him, because of discouragement, or diffidence, or experience of repeated rebuff, rather than that the positive testimony of himself, and of so many witnesses of character, is wickedly false.

Drawbaugh and his witnesses should have the benefit of the presumption in favor of truth and honesty.

When a man is relating an exceptional experience—an astonishing result, a mystery connected with spoken words—it would be more incredible if he did not remember it.

## Argument of counsel.

Resort has been had, not to the testimony, but to the theory of the inherent incredibility of the defence, and especially of the story of Drawbaugh himself.

Drawbaugh's history of himself and of his experiments and labors upon the electric speaking-telephone from 1860 to 1879, inclusive, must be either a truthful statement, or one manufactured by a wicked mind; yet, all the methods known to the profession have been applied for the purpose of breaking down his testimony, *and without success*.

Upon the course and path of his life, and his relations and dealings with all men from his boyhood down to his fifty-eighth year, the complainants have focused a light which has made luminous every detail. But we find that he bore a character, and had a life record whose honesty and truthfulness could not be assailed. All bear testimony to his steadiness, his industry, his enthusiasm in physics, and especially in electric science.

The record is full of evidence of the employment of "agents" from the community, by the complainants, in a search for matter wherewith to attack him.

It has never been true in the history of jurisprudence that a fabricated story, covering a long period and series of transactions, could stand the tests applied to it in the courts of justice.

Drawbaugh's testimony covers 332 pages, of which 180 pages are cross-examination, and the complainants commanded every available resource and all the ability and knowledge, both scientific, legal and common, that would by any possibility be put into an attempt to break a witness by cross-examination.

A careful reading of this testimony is convincing of its truth. The very faults of Drawbaugh's memory, the immaterial contradictions and changing of immaterial dates only go to strengthen the conviction that the history as related is genuine and truthful. It is without a trace of the inflexibility which characterizes fabrication. The man that speaks

## Argument of counsel.

is in harmony with the history of the man's character as related; in harmony with all knowledge of the honest, ingenious, open-minded genius, as portrayed by the account of his life.

It is said by the complainants that Drawbaugh was not a learned man; that no one but a scientist could have invented the telephone; and the fact of his busying himself with other inventions in mechanical contrivances is used as showing that he could not have conceived or had his mind upon so great a discovery as that of the transmission of articulate speech.

So far as the learning is concerned, it can be shown that successful inventors are not the product of the universities, but of natural conditions and of tendencies common enough in American civilization. Genius is innate, and the man possessing it is the man who must advance in its use.

No mere theory can give the accurate and ready knowledge which practice imparts. Von Humboldt found at Calabozo an electrical machine, the work of a man who had never seen any instrument, who had no person to consult, and who was acquainted with the phenomena of electricity only by reading the treatise of De Lafond and Franklin's Memoirs.

The Royal Society of London once elected to honorary membership a man who first demonstrated that lightning and electricity were one, whose reports as to his experiments with a kite and a key, it had formerly refused to receive and had made sport of. He stands in history and science as among the most eminent of natural philosophers. He was a "Yankee tallow chandler's son, a printer runaway boy," for whom the schools did nothing.

Michael Faraday, the son of a blacksmith, gave his attention to practical experiments with electricity, resulting in the discovery of the induction current.

Hugh Miller's great conceptions took form when, without education, he was working as a laborer at the Cromarty stone yards.

## Argument of counsel.

Ampere worked out difficult mathematical problems with sticks and stones before he had learned the names or forms of figures.

But it is said that Drawbaugh busied himself with mechanical contrivances of comparative insignificance.

So did Robert Fulton, Guttenberg and Franklin. Again, the attack is made upon the credibility of Drawbaugh's story, upon the ground that such an invention would have been widely known, and would have commanded all the resources necessary to present it to the public.

But the telephone seemed a mystery and a novelty, of no practical utility, to the learned and the rich of the great cities, long after Bell's patents were issued.

Morse, who conceived the electric telegraph, for twelve years thereafter struggled with poverty, to secure any consideration for it.

Elias Howe for years suffered the pangs of poverty and failure to get friends or capital interested in the sewing machine in this country, or in England.

Now, what is there in this case that so distinguishes it in the domain of judicial investigation as to require a reversal of settled rules of evidence?

Direct and positive affirmative evidence, unimpeached and uncontradicted, seems in the Court below to have failed of legal virtue when applied to this particular controversy; and the rule as to presumptions is so radically altered that the testimony of four doubtful witnesses that they did not hear of a fact—no, that they did not remember hearing of it—shall be received as finally closing the door against the possibility of its existence, and against the recognition of all direct and positive testimony of twenty-seven equally credible men and women, that they actually did see and hear of the thing.

And although he did apply to twenty-seven others, it is conclusively assumed that he did not have a telephone, because he did not apply to these four gentlemen. As well



## Argument of counsel.

might it have been assumed that Howe did not invent the sewing machine, because, after repeated attempts, he ceased his applications.

Although the greatest inventors and discoverers have died in poverty, or succeeded only after long failure, yet, because Drawbaugh could not at once command recognition and influence, his story is stamped as a fabrication from beginning to end.

The community corroborating him are called knaves or fools. A mind active in the direction of other invention is held evidence that this discovery was beyond his scope.

The learned Court below seems to demand a new and a special law of evidence, and a reversal of all the commonly received notions of human nature, to fit this case.

As the complainants' whole theory and the decision of the Court below rest upon the basis that Drawbaugh is a fraud, and has had the ingenuity to set up the story and the influence to get it so overwhelmingly corroborated, we submit from the record a brief sketch of "His history, surroundings and testimony."

If a charlatan, unlike his kind, he has not led an itinerant life. All that can be told of him from boyhood to age, all the evil or good that is known of him, all evidences of character, all the impressions, are written of Drawbaugh in one place and upon one community.

The story from his earliest to his latest years is a very simple and homely one. If it be true that he developed into a Machiavelli in his fifty-third year, the incongruity is worth consideration.

He was giving attention to electric science in 1860, and then conceived and talked of "*speaking through a telegraphic wire by electricity.*"

Between 1871 and 1874, Drawbaugh showed Exhibit "C," and said that the *voice* produced "*pulsations*" upon the machine.

## Argument of counsel.

At that early time he was experimenting with electricity, which seemed to be his hobby.

He was a person of remarkable ingenuity and skill. At thirteen he made a rifle, and at a later period was skilful in wood-working. At twelve he made a part of a clock. At sixteen he manufactured a small steam engine. In 1857-1859 he constructed and operated a photographic apparatus, making even the lenses himself. He made a solar transit, and a machine for wrapping electric wires. He made his galvanometers. He was applied to by others to invent, and did invent, machines for them—the tack machine for Patton, the paper-bag machine for Sengsier, and other machines for the pump company and for the axle company. He was a great mechanical genius and a “great inventor.”

All the witnesses concur as to his sobriety, his truthfulness, and his incessant and tireless industry, and of his labors, extending far into the night. He was generous and kindly, and negligent in money matters. His wife refused to sign the deed when he wished to sell their little home, to put money into the “talking machine.”

(The counsel here reviewed the evidences showing Drawbaugh's poverty.)

The able opinion of the circuit judge is exhaustive in its treatment of Drawbaugh as a conspirator, a perjurer, and as a general fraud.

(Counsel here discussed the evidence on which this charge rests.)

A BRIEF SKETCH OF THE CONCEPTION AND PROGRESS OF DRAW-  
BAUGH'S TELEPHONE.

He early began to study the subject. He experimented with the vocal organs, and had learned the fact that sound set up vibrations in solid substances.

He pursued the principle always, that the current must not be broken, and from the first his conception was of a continuous current.

## Argument of counsel.

(Counsel here goes into the evidence on this subject, showing his experiments and the progress of his invention.)

The story of Drawbaugh then, and of the record, overwhelmingly corroborated by the witnesses for the defence, is as follows:

Early conception and experiments with the continuous current, 1862, 1866, and 1867.

Tea-cup transmitter and receiver, 1866 and 1867.

Tumbler and tin cup and mustard can ("F" and "B"), 1867 and 1869.

Improvement upon "B" ("C"), 1869, 1870.

Further improvement upon "C" and the more perfect magneto instrument "I," 1870, 1871.

Mouthpiece changed to centre, and adjusting screw inserted (Exhibit "A"), 1874.

"D" and "E," perfectly adjusted and finished magneto instruments, January and February, 1875.

"L," "M," "G," and "O," from February, 1875, to August, 1876.

"H," August, 1876.

"J," "N," and "P," 1878.

The reason why Drawbaugh was seen by some of the witnesses working with the earlier machines, after the perfection of the instruments "D" and "E," on other earlier magneto instruments, was that Drawbaugh, on discovering that the magneto receiver "B," as improved and organized in the improved "C," in 1870, would serve as a transmitter, temporarily abandoned the variable resistance transmitters, "F" and "B," and did not return to experiments and progress on them till 1875. From them, through a series of experiments and improvement, came finally the perfect carbon instruments in 1878.

As to the claim that Drawbaugh was still experimenting, when defendants' evidence shows he had accomplished the invention, the answer is that the instrument in his view "was

## Argument of counsel.

not loud enough for practical purposes." He wanted it to talk out as a man talks.

The charge that Drawbaugh *did not make known his invention to his associates* in the shops where he worked has nothing to rest upon.

(Counsel reviews the evidence on this point, and also the testimony of thirty-seven of defendants' witnesses, establishing the invention of Drawbaugh.)

Without continuing an extended analysis we refer briefly, in addition to the foregoing, and in addition to the witnesses discussed and quoted, to the following equally strong and positive testimony (citing the testimony of about seventy additional witnesses).

Ephraim R. Holsinger, a newspaper man and job printer, was called by the complainants who proved by him that he published a card for Drawbaugh before June, 1874, containing a partial list of inventions, and not mentioning the telephone.

This card is as follows:

We say of it:

1. It was prepared by Holsinger, without Drawbaugh's supervision.
2. It purports only to give a list of patented inventions.
3. It purports to give a list of practical and every-day tools, used among the people where the card was issued.
4. The advertisement in it of a double machine for telephoning would have been absurd.
5. It was early in 1874, and Drawbaugh had no telephone machines ready for sale, and the card purports to advertise only for sale to the class of people about there, and it omitted the gas governor and wire wrappers and the stamp canceller, for the same reason, *i. e.*, such people did not use them.
6. Drawbaugh would not care to advertise to patent pirates the matter of his greatest work, to no good purpose.
7. His object was to get every-day work without calling attention to his "hobby."

**Daniel Drawbaugh.**

**INVENTOR, DESIGNER**

**and**

**SOLICITOR-PATENTS.**

Also Models Neatly Made To Order.

**Eberly's Mills,**

*Cumberland County, Pennsylvania.*

**Dan'l Drawbaugh,**

**INVENTOR** 

**THE FOLLOWING PATENTS.**

Shave, Heading & Shingle Cutter.  
Barrel Machinery.

**STAVE JOINTING MACHINE**, Many in use.  
Tram & Bed-staff for levelling face of Millstone.  
Blow and Driver for running Millstone.  
Nail Machinery for Feeding Nail Plates.

**PUMPS, ROTARY & OTHERS.**

*Hydraulic Ram.*

**THE DRAWBAUGH Rotary Measure-**  
ing Faucet. very extensively used.

**CARPET RAG LOOPER**-- A little  
device by which rags are looped quick and firm,  
without Needle or Thread.

**ELECTRIC CLOCK.**

**MAGNETO ELECTRIC**   
**MACHINE,**

For short line Telegraphing. Fire Alarm.  
and Propelling Electric Clocks. It can be  
applied to any form of Electric movement.

Gives entire satisfaction **USEING NO**  
**GALVANIC BATTERY.**

**For SIMPLICITY it has NO RIVAL.**

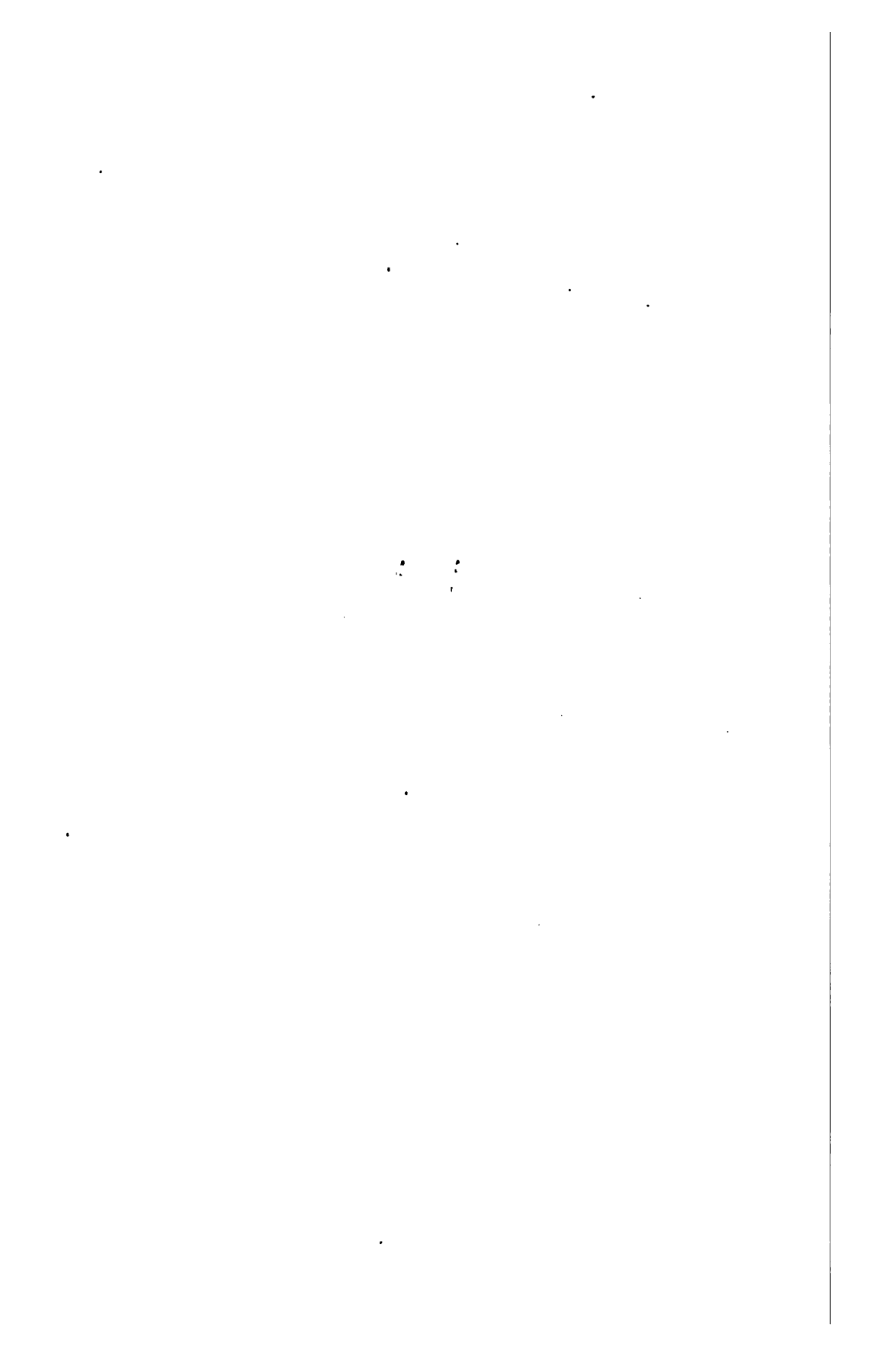

## Argument of counsel.

8. Holsinger talked through the, to him, perfect, because finished, machines "D" and "E" (not finished until February, 1875), in the summer of 1875, a year after the card; and the "experiments," as he calls them, of 1874, were with the rude and unclosed machines "F," "B" and "C."

Finally, the witness Holsinger distinctly states that his testimony for defendants is correct.

Of the witnesses, all, with the exception of eight, give their testimony as to having seen or talked with the machines prior to June 2, 1875, the date of Bell's invention; and in every case the testimony shows that the date has been fixed accurately by collateral and convincing circumstances.

To corroborate the dates we called a number of witnesses, who testified as to being told of the machines and of the common report of the machines, at the dates which the foregoing witnesses have fixed as the time they saw them; and this latter class of witnesses as accurately fix the dates.

We have, in almost every instance, called a stranger to the witness giving the direct testimony, to establish the date of such collateral fact.

(Counsel here recites the evidence.)

A number of the original parts of these instruments exist and are in evidence, and from the parts and from the testimony of Drawbaugh and other witnesses describing them, reproduced instruments were constructed, in order to show the Court how they appeared and acted, when completed in all their parts. Of the reproductions "F" was the only one of the four which was a carbon instrument.

The Court below lays great stress upon the failure of these instruments to do satisfactory work in the New York tests. The instruments were again reproduced and properly adjusted at Philadelphia, and worked perfectly.

It is difficult to see wherein the essential parts of these machines differ, and it is perfectly plain that the New York tests failed of perfect action from the rough treatment the

## Argument of counsel.

machines had had, and, from having been shaken out of adjustment.

Mr. GEORGE F. EDMUNDS, for the People's Telephone Company (Drawbaugh case), and the Overland Telephone Company:

The Court below was right in its theory that this method of transmitting speech by electrical contrivances actually existed at the time that the defendants' testimony in the Court below said that it did, or else that the whole of the defendants' testimony is false.

It was found by the Court below, that the story that was told by Drawbaugh and his witnesses was untrue.

If the things took place that the testimony tends to show, then Bell's case, as a prior inventor and entitled to prevent the use of these machines invented by Drawbaugh, has no place in this Court.

The question that you are now to pronounce upon is not whether Drawbaugh shall have a patent; it is the question of whether he and those who have taken up his cause shall have a right to use their instruments against the intervention of Bell as a prior inventor.

It is of no consequence whether Drawbaugh has an application for a patent now pending, or whether he never made an application, or thought of making an application, for a patent.

The point is whether Bell is the first and prior inventor of a useful invention, and has made a proper application for its exclusive use.

What is to become of the Drawbaugh invention or the Gray invention has nothing to do with this case.

A telephone is a contrivance for transmitting speech; an extremely useful, ingenious and valuable invention.

Are you to say that every man who lived in this neighborhood in Pennsylvania, and that this old unlettered man, Drawbaugh, whose life had been pure from beginning to end, are liars?



## Argument of counsel.

I deny it. It is against human experience; it is against human morals; it is against every principle and test.

I want to ask Your Honors to read this testimony both of the complainants and of the defendants, in this People's cause, and the Overland cause, which brings in some later testimony, and see whether you can say, as Judge WALLACE did, that the statement of this poor old inventor himself is a fabrication, and that every other part of it, as to events that they say took place before this patent of Bell was applied for, was a pure delusion, and that the testimony of scores and scores of men and women, having no common concert, was a fabrication.

Suppose Drawbaugh had applied for a patent before Bell, and the Commissioner of Patents had said: "I will not grant you this telephone patent because it is not a useful invention," and we appeal and come here with this testimony, could there be a doubt that you would say that that thing did exist, and that Drawbaugh did it? It is impossible to deny it.

I believe you all would have thought, as Orton thought, and as the Stock Exchange thought at New York, and as everybody else thought at that period of time, "We cannot grant this patent because it is a mere toy."

I think the key to the whole of it is, that at the time when this invention was being carried forward by this man, nobody believed it was otherwise than the idea of what is now called a crank. Some people—for people differ in their emotions and their sensibilities and their perceptibilities—said, "It is impossible."

Nobody believed it. That would dispose of one class of these witnesses, who said it was impossible. The other class said: "What good will it do that you can speak through this piece of wire and by this contrivance?"

It took a year or more before Bell and all his coadjutors, with millions of capital and enterprise and ambition behind to push it forward, and not an over amount of scruples

## Argument of counsel.

before to retard it, brought his invention to be believed in and invested in and operated by the public as a useful invention. It turns out to be useful.

If Drawbaugh had done the same thing that Bell had, in the same time, you would have believed the whole thing was a conspiracy and a lie, and that the thing did not exist now. You would not have believed the evidence of your own senses.

Witnesses are called upon, one by one, to state what they remember; that they saw the thing and heard the voice. How are you going to disbelieve it? Why, Judge WALLACE says: "It is absolutely incredible that Drawbaugh could have done that thing." That is the honest statement of the judgment of the Court below, and it is the best ground on which the complainants' case below and the appellees here can be put.

That is the ground upon which the Court below held that the Drawbaugh contrivances, machines, instruments, operations and facts never existed.

Now, I beg that Your Honors will not commit yourselves to any such theory of the weighing of human testimony as that. But let us see how they treat Drawbaugh alone. I don't mean to leave Mr. Drawbaugh in the category in which Mr. Justice WALLACE left him.

How are you going to tell whether a man is an honest man or not? All that we can judge by is the life and conversation of the person in question. If a man has been an immoral man, you doubt him.

Suppose a man, whose life from his birth to the day of giving his testimony has been pure, has been upright, has been respected, and that in the whole forty years that he had lived in that community never a shade or a suspicion had touched it; and he tells you a tale of an event that he himself was the doer of, and which is within the range of sanity; would you believe him, although two years, five years, ten years after, a scientist, glorified by capital and by fame, had

## Argument of counsel.

said: "I have done that thing, and therefore you could not have done it before?" That is a statement of this case as applied to the testimony of Drawbaugh himself, if you took him alone.

And he is surrounded and fortified by scores and scores of honest and respectable people, whose characters are not impeached any more than his is, who say that they saw and heard that thing done long before Bell's discovery. So that I submit that you cannot fail to say that it is proved that this old man, in that obscure place, did do the thing that Bell did, in 1876 or 1877.

I am under the impression that it is not really disputed by the gentlemen on the other side that if the things took place at Elberly's Mills, from 1869 to 1875 and '76, that the defendants' witnesses say did, and that Drawbaugh says did, then Drawbaugh used the same principle, employed the same method, the same process, in substance and in effect that were employed by Bell.

If, therefore, the contrivance is the same in substance, and it existed before, then Drawbaugh and his friends ought to be allowed to use it. If it is not the same, then clearly, of course, they ought to be allowed to use it, because it does not infringe Bell's patent.

Something has been said about Gray's having applied for a telephone patent in 1876, the same day that Bell did, but I will not dwell on this. What I have said is, to my mind, the key to the whole thing on the question of priority.

Judge WALLACE stood on the idea that it is intrinsically impossible that Drawbaugh could have had such a conception. Why? Because it required what is called scientific training. A force of nature has never been discovered by such logical steps as Judge WALLACE thought necessary. Bell himself was struggling and struggling to do something which he could not reach. How did he get it at last? Accidentally. It was not logic that did it. It was not logic that led Franklin to put his kite up in the sky. It was not logic that has

## Argument of counsel.

led anybody to discover anything. It is not training that does it, although training is useful.

Take Arkwright, the great English inventor of the cotton spinning machinery; was he a student, a professor, a teacher of any kind of science? Not a bit of it. He was a barber.

Watt, another Englishman; where was his scholasticism, his great accumulation of scientific knowledge?

I can run down through Fulton, and Whitney, the cotton-gin man; and what was he? A man skilful in mechanics? No; he was a lawyer in an obscure country town in Georgia, living on a plantation, and teaching the children.

This lawyer invented the cotton-gin. Up start my brothers on the other side and say, as Judge WALLACE said below, "Why it is utterly impossible."

I could go through, of course, innumerable illustrations which demonstrate that the correlation between what we call scientific knowledge and education, and the discovery of these important forces of nature and their application, has no connection whatever. And that it is more often than otherwise that the obscure genius whom God made, and whom the schools did not make, and the obscure mechanics have been men who have brought to the knowledge of mankind most of the things which we now consider to be the most useful to us.

I must say that in respect of the topic to which I have called Your Honors' attention, that it is the end of this case, if Your Honors will take this testimony as to what took place in an honest and respectable community in Pennsylvania for years and years, year in and year out, proved by the whole body of the community, of every calling, in support of this honest old man whose career is not questioned as a man of purity of life, of uprightness of character, although poor and sorrowful; there is an end of it, and if you will only read the testimony, I have nothing more to say.

Oral argument of Mr. JAMES J. STORROW, for the American Bell Telephone Company, on the Drawbaugh defence:

## Argument of counsel.

Drawbaugh's story is that he had electric speaking telephones for eight years before the Bell patent, at his machine shop at Eberly's Mills; and yet these telephones were never used for any useful purposes whatever.

According to his story they were kept in a box, and he took them out once in a while to experiment with, or to entertain visitors. That was the only use he ever made of them.

It is impossible that a practicable telephone, successful, operative, could have been there without coming into use.

Not a human being in the world ever transmitted speech by reason of any information derived from Drawbaugh. The telephones which have come into the world are the result of the independent inventions of other persons, and are not due to any information from Drawbaugh.

We know how Bell's instruments astonished the world, how his feeble instrument at the Centennial made him famous.

Such an invention could not help publishing itself. If it exists, it gets published necessarily.

The argument that was made yesterday was that Mr. Orton, the president of the Western Union Company, saw the telephones of Bell, in the spring of 1877; examined them, and pronounced them to be a mere scientific toy.

The facts are that in the summer of 1877, Mr. Orton said that the Western Union *must* have the speaking telephone, and on September 6, 1877, made a contract with Dölbear to at once put out telephones, and about the same time made a similar contract with Gray.

On December 1, 1877, Mr. Orton had organized a new company, the "American Speaking Telephone Company." In the spring of 1878, Mr. Orton's companies were actively engaged in furnishing telephones for commercial use.

Drawbaugh was first set up to anticipate the Bell patent by a statement in the newspapers, in the summer of 1880, that his associates had proposed to obtain a patent for him as the first inventor of the speaking telephone.

## Argument of counsel.

That was the first announcement of Drawbaugh to the world. This suit was brought in October, 1880, and resulted in a preliminary injunction.

There was a hearing on a motion against the Overland Company at Philadelphia, in which the Drawbaugh defence was set up.

The Drawbaugh case, on its merits, has been considered by Judge WALLACE and by no other judge.

The defendants did not use and never intended to use any telephone made or devised by Drawbaugh. A company formed in the beginning of 1880 had proposed to use telephones devised by Klemm and by Tisdell, and were afraid they would be enjoined, and after they had started in that enterprise, they bought Drawbaugh's pretentions.

Drawbaugh is set up as a prior inventor to destroy the Bell patent. Drawbaugh's telephones were never used practically for any useful purpose. That they were not used is proof that they did not then exist or were not then capable of use.

All the apparatus alleged to have been made before 1875 by Drawbaugh has gone so far into ruins that it is impossible to transmit sound with it, except instrument "A" alleged to have been made in the fall of 1874. That instrument is a good *receiver* for a speaking-telephone, but it is not a speaking-telephone. It takes two instruments to make a telephone.

Of these instruments alleged to have been made in or before 1874, the parts absolutely required to make any sound cannot be restored, or their character learned, except from Drawbaugh's deposition.

After the injunction and the answer and replication, we put in our usual *prima facie* case, proved our patent and infringement. Then the defendants took testimony about Drawbaugh's story—one hundred and twenty-five witnesses. Then we took about one hundred witnesses on the Drawbaugh story. Then they took about two hundred, and then we took some more, and so on, until after about three years

## Argument of counsel.

and a half of work, in June, 1884, the case was completed and ready for argument.

The case then went to a hearing, and was decided by Judge WALLACE in favor of the Bell patent, about the first of December, 1884.

When the Drawbaugh decision was announced, the Overland Company had not completed their testimony, and they took more testimony about Drawbaugh.

By agreement that was incorporated in the Drawbaugh case, and laid before Judge WALLACE, and argued before him on the last of November, 1875, and upon that hearing he affirmed his former decision.

We are justified in saying that whatever they did not supply at the second hearing does not exist. Mere oral recollections never yet made out a case.

In such cases, the defendant's proof must remove doubts; every reasonable doubt should be resolved against him.

*Coffin v. Ogden*, 18 Wall. 120 [9 Am. & Eng. 125]; *Parham v. American Buttonhole, O. & S. M. Co.* 4 Fish. Pat. Cas. 468.

Oral recollections cannot prevail against reasonable inferences from conduct.

*Wood v. Cleveland Rolling Mill Co.* 4 Fish. Pat. Cas. 550; *Atlantic Works v. Brady*, 107 U. S. 192 [14 Am. & Eng. 380].

Such testimony should be weighed with care, and the defence allowed to prevail only where the evidence is such as to leave no room for a reasonable doubt upon the subject.

*Howe v. Underwood*, 1 Fish. Pat. Cas. 162; *Roberts v. Reed Torpedo Co.* 3 Fish. Pat. Cas. 630; *Boulton v. Bull*, 1 Carpmael Pat. Cas. 137 [1 Am. & Eng. 59]; *Kendall v. Winsor*, 21 How. 322 [7 Am. & Eng. 1.]

Incomplete attempts to construct a machine amount to nothing as evidence to support such a defence.

*Kelleher v. Darling*, 4 Cliff. 424; *Judson v. Bradford*, 3 Ban. & Ard. 539; *Ely v. Monson & B. Mfg. Co.* 4 Fish. Pat. Cas. 79.

## Argument of counsel.

The inoperative character of the machine disposes of the oral testimony.

Johnson *v.* Root, 2 Fish. Pat. Cas. 292; Cahoon *v.* Ring, 1 Fish. Pat. Cas. 408; S. C. 1 Cliff. 592; Hayden *v.* Suffolk Mfg. Co. 4 Fish. Pat. Cas. 94; Motte *v.* Bennett, 2 Fish. Pat. Cas. 642; McCormick *v.* Seymour, 3 Blatch. 213; Seymour *v.* Osborne, 11 Wall. 516 [8 Am. & Eng. 290]; Aultman *v.* Holley, 6 Fish. Pat. Cas. 534; S. C. 11 Blatch. 317; Colt *v.* Massachusetts Arms Co. 1 Fish. Pat. Cas. 116; Parham *v.* American Buttonhole, O. & S. M. Co. 4 Fish. Pat. Cas. 468; Smith *v.* Fay, 6 Fish. Pat. Cas. 450; Brown *v.* Guild, 23 Wall. 181 [10 Am. & Eng. 1].

The disuse of a machine may be explained.

Hayden *v.* Suffolk Mfg. Co. *supra*; Snow *v.* Tapley, 13 Off. Gaz. 548; Goodyear *v.* Day, 2 Wall. Jr., 283; Roberts *v.* Reed Torpedo Co. 3 Fish. Pat. Cas. 630; Roberts *v.* Schreiber, 18 Off. Gaz. 125.

This is an attempt to defeat a meritorious patented invention by proof that something similar had been previously known, though it had never been perfected, and had never been any useful contribution to human knowledge or convenience.

Smith *v.* Fay, 6 Fish. Pat. Cas. 446; LaBaw *v.* Hawkins, 1 Ban. & Ard. 428; Ransom *v.* Mayor of N. Y. 1 Fish. Pat. Cas. 252; Cahoon *v.* Ring, Id. 397; Goodyear *v.* Day, *supra*; White *v.* Allen, 2 Fish. Pat. Cas. 453; Gottfried *v.* Phillip Best Brewing Co. 5 Ban. Ard. 4; Putnam *v.* Hollender, 19 Blatch. 48; S. C. 6 Fed. Rep. 882.

The defendants' proof must remove all doubts; a bare preponderance is not enough.

Washburn *v.* Gould, 2 Robb Pat. Cas. 206; S. C. 3 Story, 122; Magic Ruffle Co. *v.* Douglas, 2 Fish. Pat. Cas. 330; Roberts *v.* Dickey, 4 Fish. Pat. Cas. 532; Smith *v.* Fay, *supra*; Crouch *v.* Speer, 1 Ban. & Ard. 145; Stilwell & B. Mfg. Co. *v.* Cincinnati Gaslight & Coke Co. Id. 610; Hawes *v.* Antisdell, 2 Ban. & Ard. 10; Wood *v.* Cleveland Rolling



## Argument of counsel.

Mill Co. 4 Fish. Pat. Cas. 550; Parham v. American Buttonhole, O. & S. M. Co. Id. 468; Comstock v. Sandusky Seat Co. 3 Ban. & Ard. 188; U. S. Stamping Co. v. Jewett, 18 Blatch. 469; Rogers v. Beecher, 18 Off. Gaz. 793; Doubleday v. Beatty, 11 Fed. Rep. 729; Thayer v. Hart, 20 Fed. Rep. 693; Patterson v. Duff, Id. 641; Worswick Mfg. Co. v. Buffalo, Id. 128; Gloucester Isinglass & Glue Co. v. Brooks, 19 Fed. Rep. 426; Lockwood v. Cutter Tower Co. 18 Fed. Rep. 653; Atlantic Works v. Brady, 107 U. S. 192 [14 Am. & Eng. 380]; Woodman v. Stimpson, 3 Fish. Pat. Cas. 98.

Testimony should leave no room for a reasonable doubt upon the subject.

Crouch v. Speer, and Hawes v. Antidel, *supra*; Judson v. Bradford, 3 Ban. & Ard. 539; Willett & Fister, 18 Wall. 91.

The Courts attach great importance to the failure of the party, on whom the burden rests, to produce the best qualified witnesses.

Smith v. Whitman, 6 Allen, 564; Clifton v. U. S. 4 How. 242; Gay v. Parpart, 106 U. S. 679; The James Martin, 5 Hughes, 448; National Car-Brake Shoe Co. v. Terre Haute Car & Mfg. Co. 19 Fed. Rep. 514; Standard Measuring Machine Co. v. Teague, 15 Fed. Rep. 390; Commonwealth v. Webster, 5 Cush. 316; McDonough v. O'Neil, 113 Mass. 92; Cheney v. Gleason, 125 Mass. 166.

The defendants must prove their case, beyond a reasonable doubt, earlier than Bell's conception, and the burden to do this is on them. They must prove a complete invention.

O'Reilly v. Morse, 15 How. 108 [5 Am. & Eng. 483]; Brodie v. Ophir Silver Mining Co. 4 Fish. Pat. Cas. 137; Dixon v. Moyer, 1 Robb Pat. Cas. 324; Adams v. Edwards, 1 Fish. Pat. Cas. 1; Woodman v. Stimpson, 3 Fish. Pat. Cas. 98; Draper v. Potomska Mills Corp. 3 Ban. & Ard. 214; Reed v. Cutter, 1 Story, 590; Reeves v. Keystone Bridge Co. 1 Off. Gaz. 466; Kneeland v. Sheriff; 2 Fed. Rep. 901; Webster Loom Co. v. Higgins, 105 U. S. 580 [14 Am. & Eng. 70]; Roemer v. Headley, 19 Fed. Rep. 205.

## Argument of counsel.

Evidence is to be weighed according to that which it is in the power of one party to introduce and the other to contradict.

Clifton v. U. S. 4 How. 242.

If the proof in the record does not come up to what the story would furnish, if true, it is disproof of it.

Of written proof there is none on the side of the defendant. Drawbaugh has got nothing but the recollections of men, except the testimony of these *remains* of his machines. These are said to be the earliest remains. This tumbler F and tin can B were made and used in 1867 or 1868. That tumbler never was of any value. It is no part of an electric speaking-telephone. The story is that that was made in 1867, and that it talked in connection with this, the can receiver B.

A bladder was tied over its top on the line M; C, E, D were the working parts; the rod C hung down, terminating with the round plate D. The plate E was supported above the plate D by a rod, which went from the point *e*, on the upper plate E, to a diaphragm M, which was a bladder tied over the mouth of the tumbler at M. If a metal rod were continued up from *e*, the centre of plate E, to the line where the bladder M is, or where the bladder is said to have been, that would be what Drawbaugh says was the condition.

You would get E held by a strut from the under side of the bladder. It must be a stiff rod; a string would not do, because it is necessary the plate should follow the motion of the bladder, and it must be pushed down as well as pulled up.

If you have got a bladder tied over the top of that tumbler and these parts inside, or to be put inside, and you want to change them or alter them, or adjust them or arrange them, the bladder being tied on there cannot be taken off, because the bladder, put on wet, stretches itself on being allowed to dry, and you could not get that off without having to wet it and stretch it all over again.

The "reproduction" has an iron diaphragm, and all the

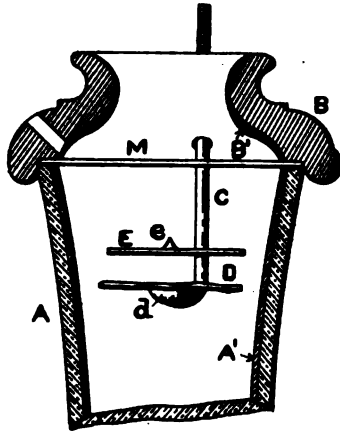

*Broken Tumbler, F, 1/2 size.*

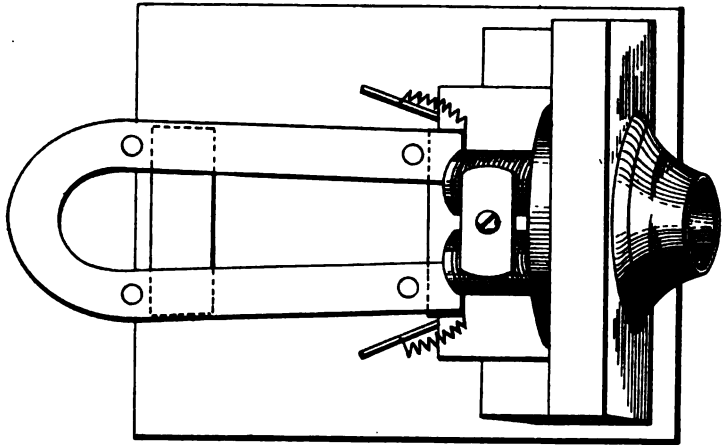

*Drawbaugh's Alleged Reproduction of C.*

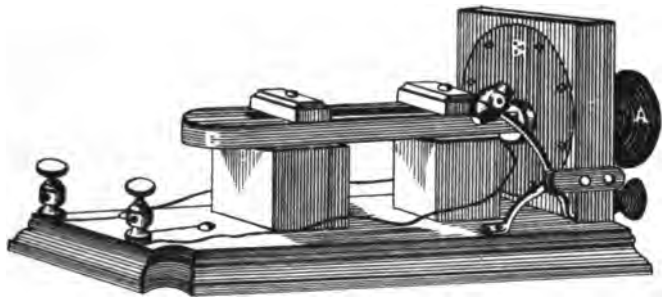

*Bell's Telephone in use before Apr. 5, 1877.*

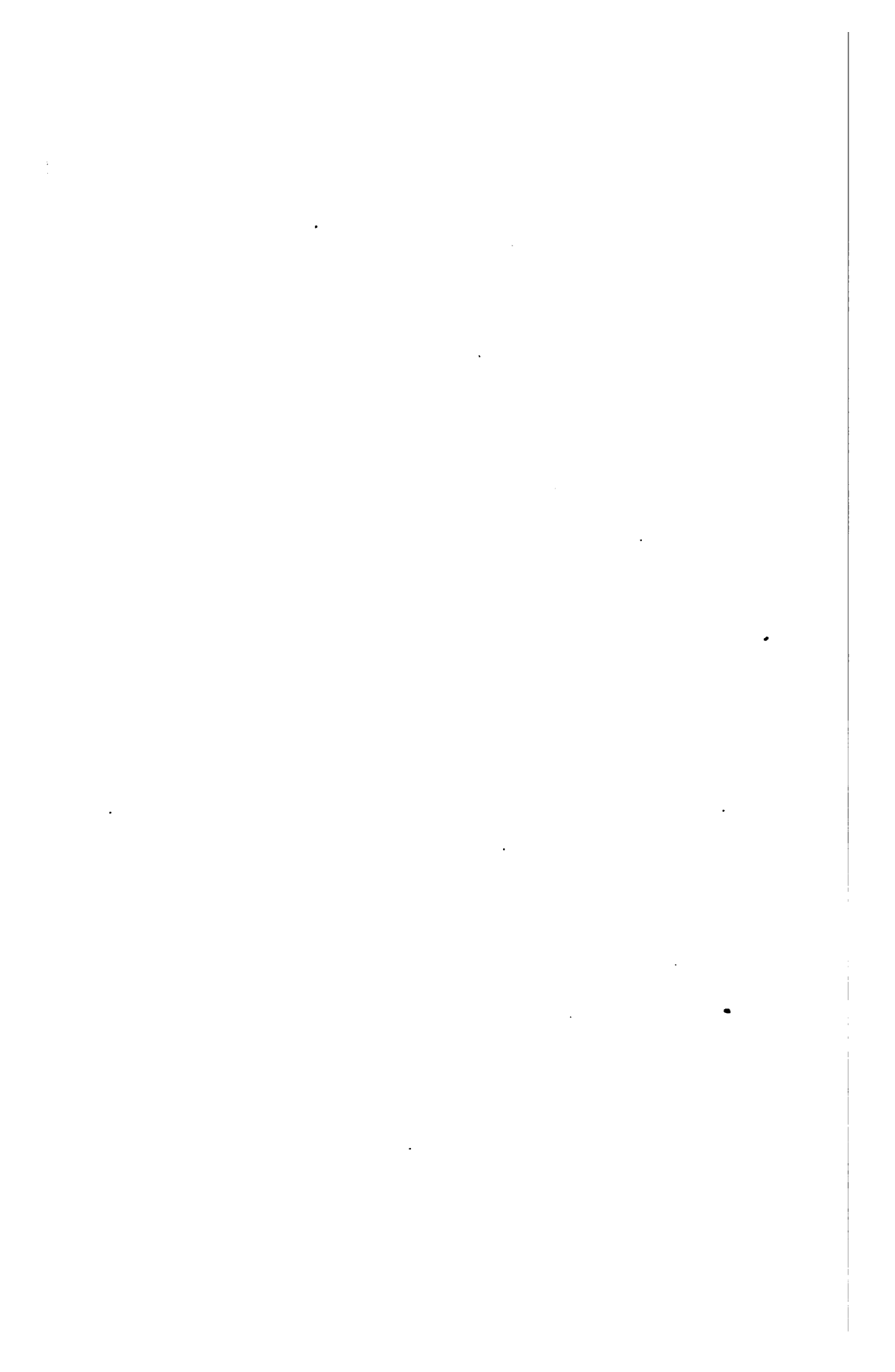

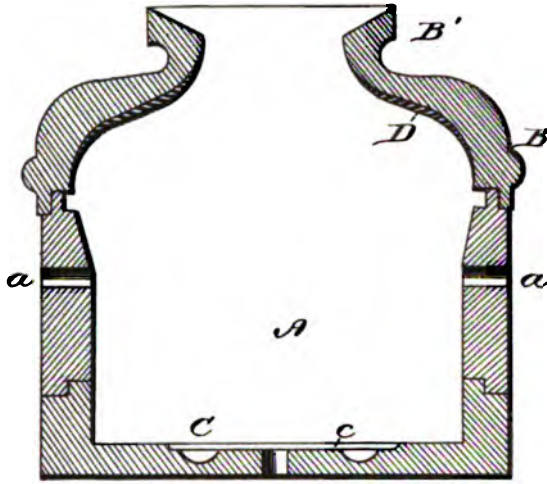

1, As first sworn to.

*Longitudinal section showing  
electro-magnets and diaphragms.*

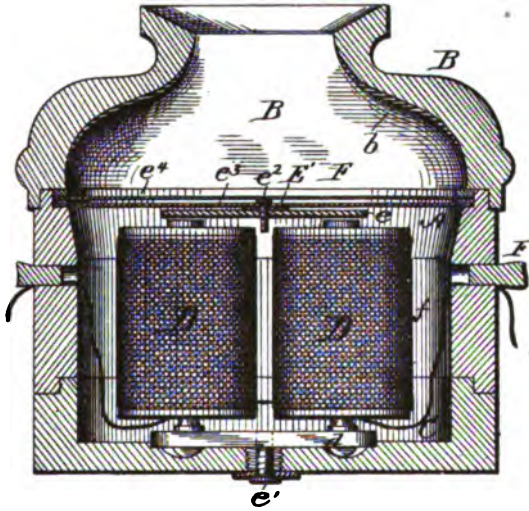

1, As added to by Draubach, after it was first sworn to.

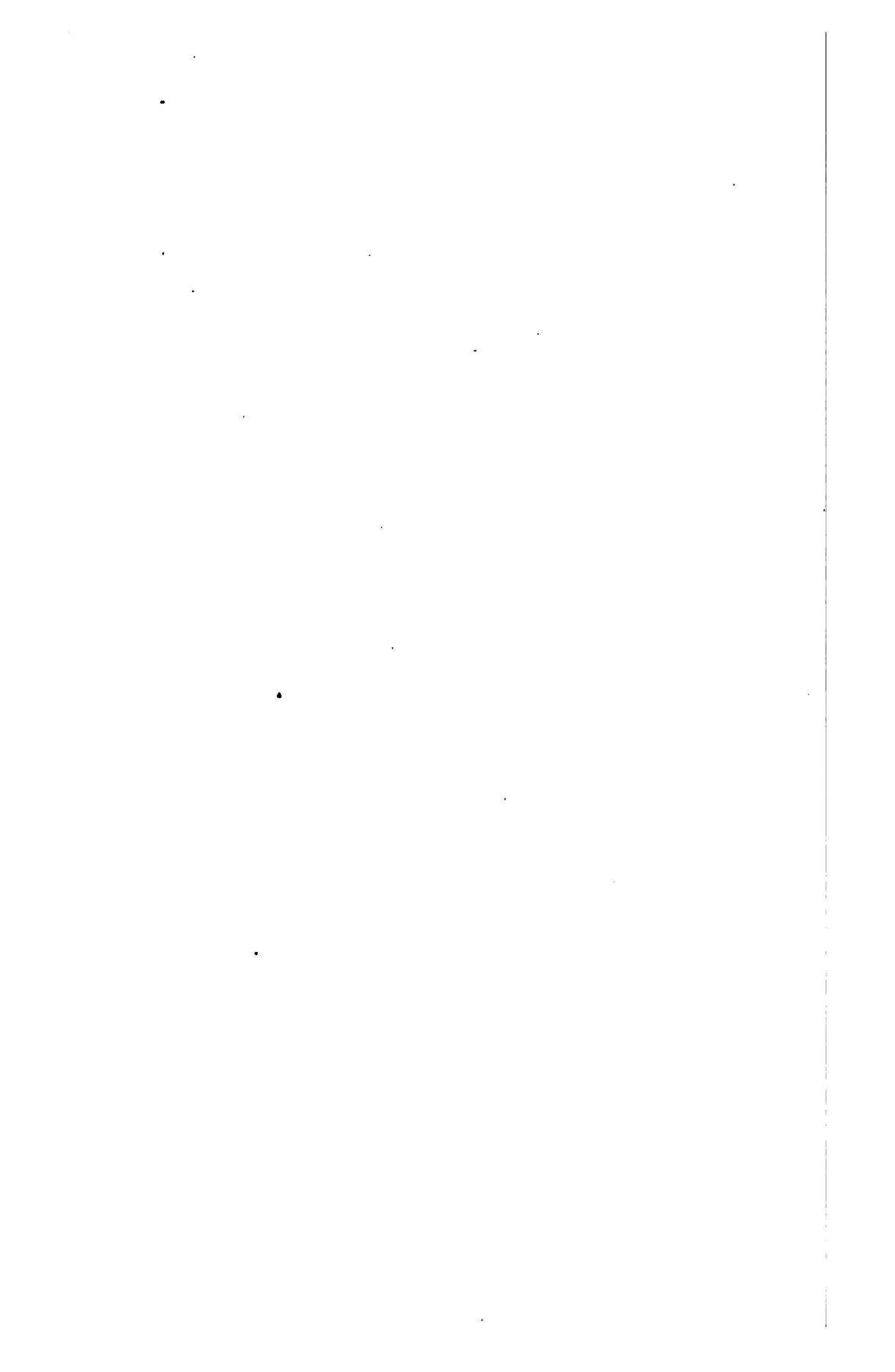

*Instrument marked A full size  
Harrisburg Pa, May 2<sup>nd</sup> 1881.*

*W. H. H. Knight,  
Del.*

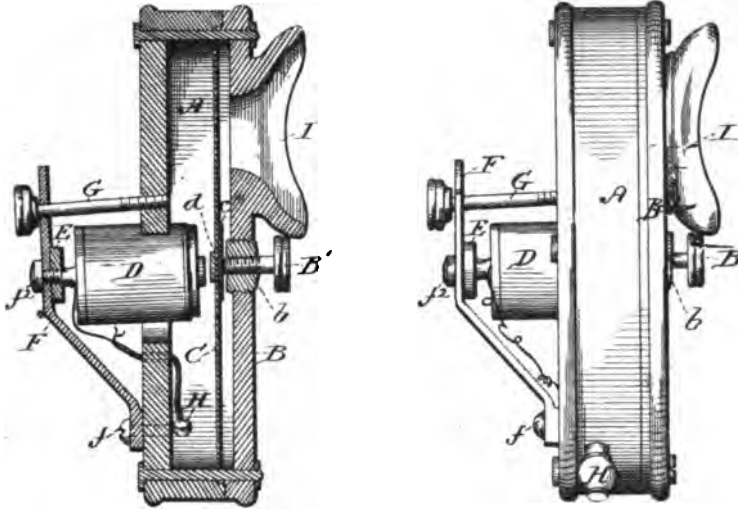

*References.*

- A. Case of black walnut.*
- B. Cover or cap to same.*
- B'. Adjusting screw for diaphragm; brass.*
- b. Screw block in cap through which B' passes.*
- C. Diaphragm; of thin black walnut.*
- c. Rubber cemented to C.*
- D. Electro-magnets.*
- d. Armature on diaphragm.*
- E. Plate connecting magnets.*
- F. Bracket to support magnets.*
- f. Screws securing same to case.*
- f'. Screw holding plate E to bracket.*
- G. Adjusting screw for bracket.*
- H. Screw cups.*
- I. Mouth or ear piece.*
- i. Conductors or wires.*

*W. H. H. Knight.*

1

2



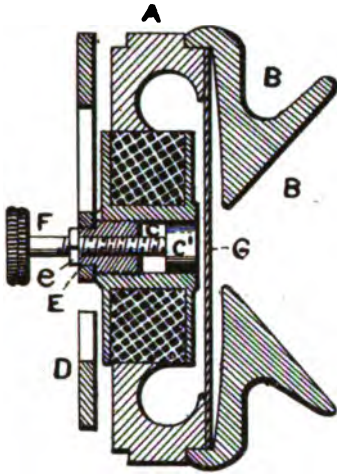

*Section of D.*

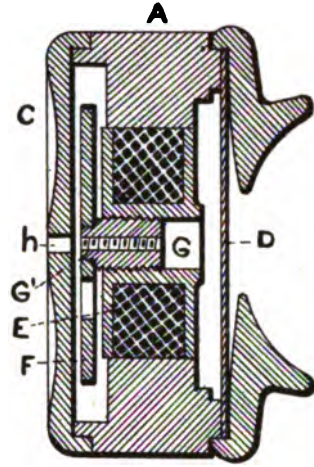

*Section of E.*

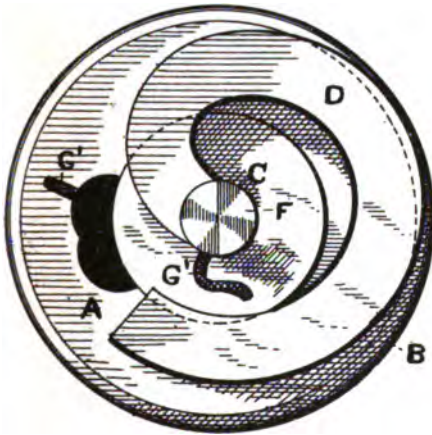

*Draught's Exhibit D.*

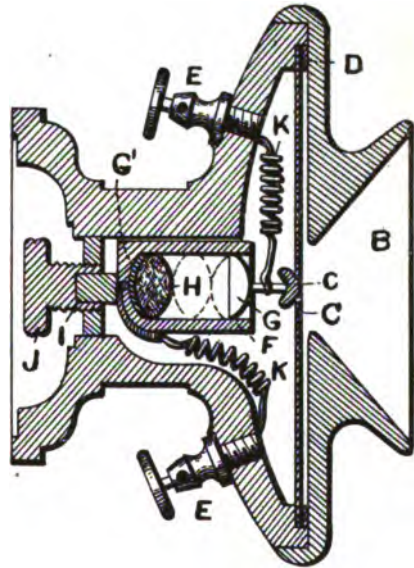

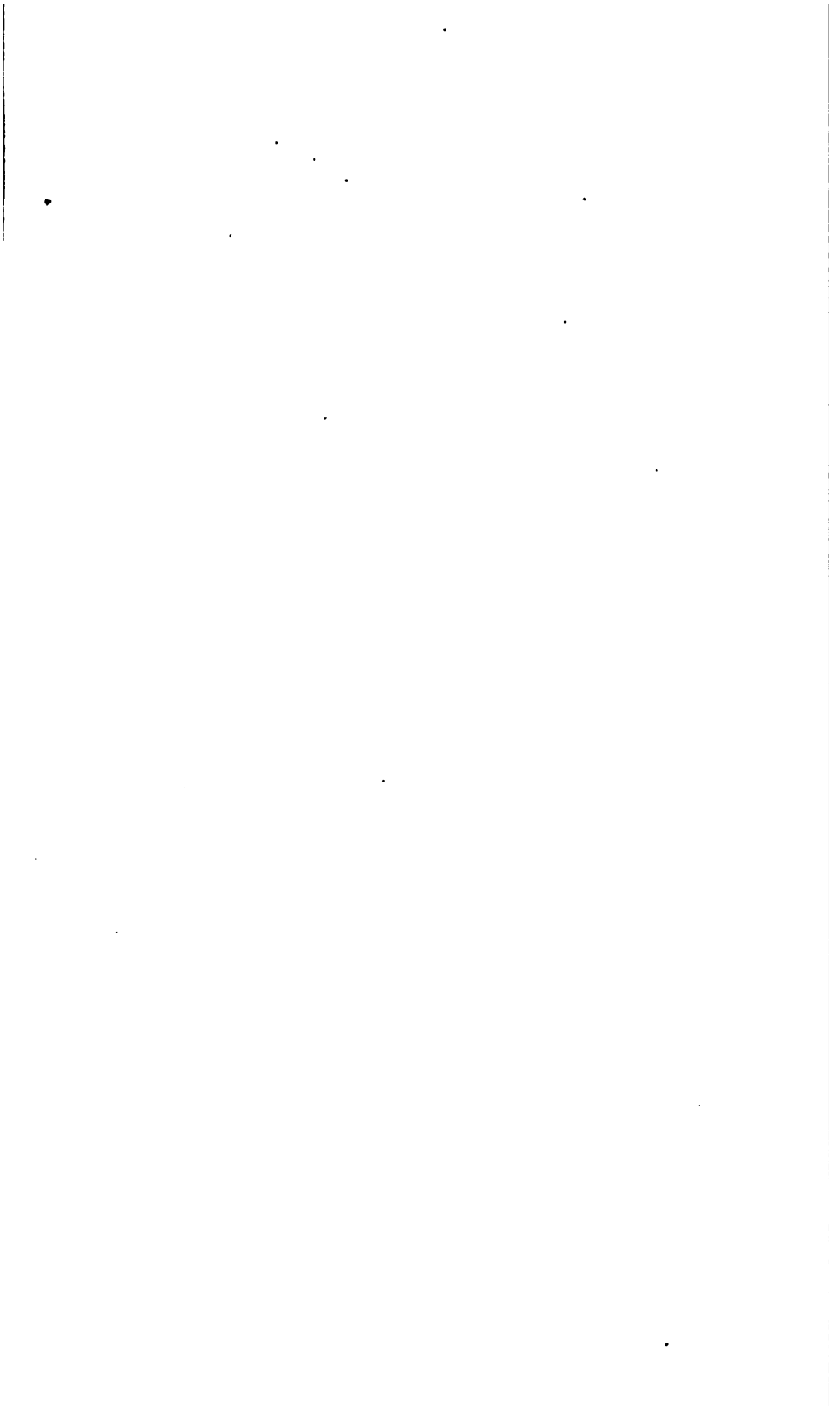

Instrument marked H full size Sheet 2.  
 Harrisburg Pa. June 20th 1881.  
 W. H. H. Knight.  
 Del.

X  
 Front elevation, open.

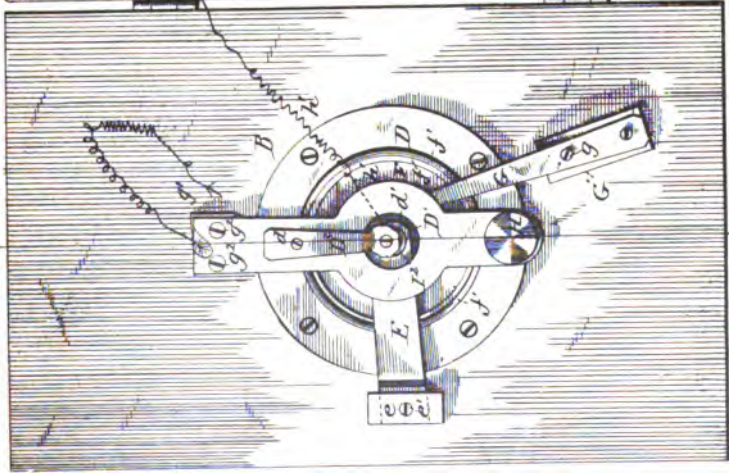

Longitudinal section  
 on line X-X.

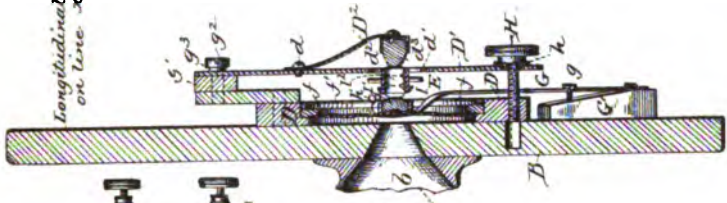



*Instrument marked F Reproduced.  
Harrisburg August 8<sup>th</sup> 1881.*

*W. H. H. Knight.*

*"Full size"*

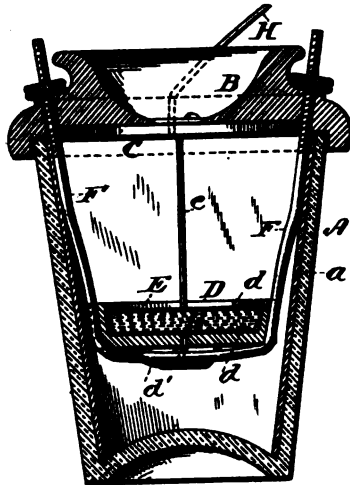

*Lower plate.*

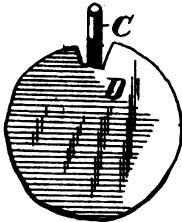

*Upper plate.*



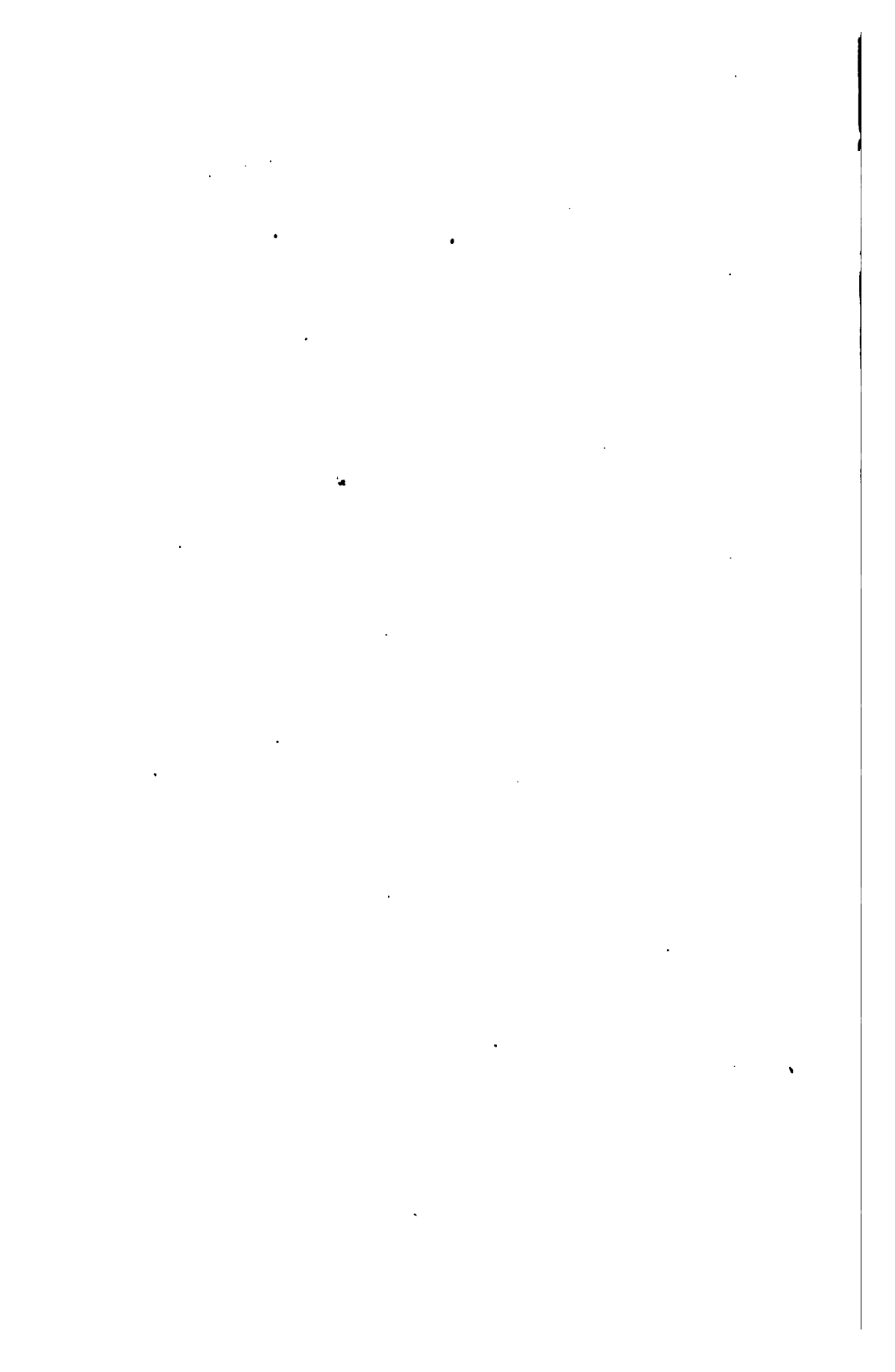

## Argument of counsel.

parts fastened to that. It is quite a different arrangement. If you throw away the whole tumbler of the "reproduction" it would work just as well; so if there was a bottom to the tumbler and you wanted to put in the working parts or adjust them, you could not do it. If Drawbaugh had that tumbler with a bottom on, he never had such parts inside.

He says that at a very early time, if the tumbler ever had a bottom to it, it was broken off; and every witness, with one or two exceptions, swears that when they saw it there was no bottom. That may be true, or it may be merely because they see no bottom on it now. (Counsel here refers to cut given at page 71 *ante*.)

This is the receiver B, which he said he made first out of an old paint can, strapped to a board by a piece of tin laid over it and one tack driven at each end. That tin can is said to have been covered with a bladder across this end, tied on with a string, next the thing in front of it in the drawing; and it is alleged that an armature was fastened to the centre of the diaphragm, and that this thing in front of it was an electro-magnet placed in front of it. He says that was a telephone receiver; it is called the *tin can receiver B*. If his description is true, that would make a receiver on the principle of the receiver of the Bell telephone. The *Scientific American* of September 9, 1876, described Bell's *first* form of telephone as made of "a tin can with an armature glued to it, and an electro-magnet in front of it." (See cut at p. 73, *ante*.)

It is said that C is the remains of the next instrument. The allegation is that the instrument when first made was something like this "reproduction;" that it had a diaphragm, somewhat as now; that it had this magnet on it, like this, an electro-magnet in front of the diaphragm, and this permanent magnet behind it, to magnetize the core of the electro-magnet.

The resemblance between Drawbaugh's alleged second form and Bell's second form is also striking. Then the story is that the next instrument made is this. When this was

## Argument of counsel.

produced in the case, and sworn to by the first lot of witnesses, it was nothing but a shell without works inside.

During the taking of the testimony they put in a diaphragm which was made for the purpose. That diaphragm was not made in there when it was first sworn to. They also put in, during the taking of the testimony, and after several of the witnesses had sworn to it, an electro-magnet which they said had been found in Drawbaugh's garret and he thought might be the original; but when it was first put in and sworn to by the first lot of witnesses, there was nothing in it except a wooden box,—no diaphragm, no magnet. So before they finished taking testimony they got it into this condition. The other parts were found in 1881, while we were taking the testimony.

The magnet which they found and brought in was spoken of by Drawbaugh as the magnet which was in use with that instrument.

The next instrument which they speak of is this, called A. Here is a section of it. It contained inside a diaphragm of walnut veneering C. In front of it is the thin air chamber, like the second Bell patent, and then one small opening into it with a mouthpiece I. You can see the diaphragm, the heavy black line C, and this opening I into it. At the centre of the diaphragm, at the back side, is to be seen a piece of soft iron *d* to serve as an armature, and behind that is an electro-magnet D, which you see projecting out at the rear; and there is an adjusting screw *g*, to enable you to regulate the distance between that projecting magnet and the armature.

The next pair of instruments which they say was made was this pair marked D and E.

E is essentially a copy of D, except that it has a wooden cover over the back to cover in the snail-shaped magnet. Drawbaugh says that D had such a cover, but it got broken or lost. These, whenever they were made, were very good speaking-telephones.



## Argument of counsel.

They have got a small core, very short, C'. The heel piece of it (the back end of it) is screwed into a permanent magnet, D, which is coiled up in order to get it into small shape. There is one just like it in E, covered by a cover. So that they have got the improvements described in the second Bell patent,—a soft-iron core magnetized by applying a permanent magnet to the back end of it. They have got the metallic diaphragm, an iron diaphragm G (it is common "tin," I suppose, a plate of iron tinned over), placed close to the pole of the magnet. In front of that they have got the peculiar thin air space of the modern commercial telephone, and the centre opening B.

Every refinement that is in the modern telephone of to-day, every refinement that is in the Bell telephone, is in these magnetos D and E, said to have been made in the spring of 1875.

That peculiar air space which Bell got as the result of experiment after experiment is in the most perfect form in D and E.

These were put in evidence in 1881. They are sworn to by various witnesses, as having been made in the spring of 1875.

Drawbaugh says he does not know in what year they were made and the case has got to turn on the question whether those were made the year before the Bell patent or after.

These instruments, D, E, have got a rather large core compared with the permanent magnet, so that they are not as efficient as they ought to be, but it does not prevent them from talking.

The next instruments which are said to have been made are those carbon microphones.

There are four, G, O, L, M. A variable resistance carbon microphone is two pieces of hard carbon in contact, one carried on the diaphragm and the other supported behind it, so that the vibration of the diaphragm will vary the pressure between them. These are said to have been made

## Argument of counsel.

before the Bell patent. The next pair are two, L, M, which are not different in substance from some of the others.

The next instrument which they produce was H, which they say was made in the summer of 1876, about August, 1876, perhaps improved a little after that. You will see if you open the Blake transmitter the resemblance between them.

This has the mouthpiece like the Blake and the thin air space inside.

The next instrument said to have been made is called J. It does not differ from H, except that it has two sets of contact, each of which is the same as in H, mounted on the same diaphragm. This was not an improvement on H. These instruments are very nicely made; the same is true of G, O, L, M, N.

Now it seem to me that a man who had the capacity and the skill, and tools and materials to make these nice instruments, could not have gone eight years with that rude contrivance, the broken tumbler F, as one of the best he had, if he had believed that it contained so precious a thing as a speaking-telephone.

The New York tests were in March, 1882; the Philadelphia tests were three years later, in February, 1885, with a new set of instruments, made in 1884.

In the New York test all that Mr. Benjamin heard from the tumbler and tin can used together was "a sound and now and then a word."

The whole case for the defence rests upon the assumption that when a large number of men have sworn to speech through instruments at Drawbaugh's shop, the fact is proved beyond doubt,—even though the instruments are proved to be incapable of doing what is sworn to. More than half of them swore to speech through instruments which cannot talk.

When Mr. Benjamin, after these trials, testified about them, the best he could say of "F reproduced" and "B reproduced" was: "I recognized and repeated *words* and *parts* of series of irregular numbers."

## Argument of counsel.

The test continued through three days, but they never after the first forenoon ventured to repeat any tests with "F reproduced" and "B reproduced."

The inside of this tumbler, in this "reproduced" instrument, consists of two rods F F running down on each side. They support this box *d*, which is of wood; a metal plate laid in its bottom inside at *d*; a rivet goes up from the rods at *d'* to the metal lining-plate *d*.

The consequence is, that an electric current, brought in by a wire attached to the upper end of this rod F, will come down the rod, up through the rivet to the metal lining *d* inside of the box, then through the carbon powder, which is placed in a mass on that metal lining, to this upper plate E. Then the current goes up that rod *e* to the diaphragm *c*, which is of metal, and then off from that diaphragm by a wire H around to the battery, and so on.

The work is done by varying the pressure upon the mass of carbon powder in the wooden box, by compressing it more or less by the vibratory movement given to the upper plate E by the diaphragm *c*, when the diaphragm is spoken to. That plate E is loose, in the wooden box of the "reproduction," so it can vibrate.

The difference between the reproductions and the originals showed that the originals could not have transmitted anything.

Why did it happen that the instrument which Drawbaugh had sworn to as a reproduction in 1882, and tried in New York, could not talk, and that the one which we tried in 1885 did talk?

In the first place, they didn't call Drawbaugh or a human being to say that this was a true reproduction. They called Professor Barker, and he said that so far as he could see the new one, the Philadelphia one, was like the New York one; but he did not know what was inside of it in certain ways, and he did not know the manner of its use. In New York it was laid down upon a table upon a block of stone.

## Argument of counsel.

When we went to Philadelphia to try it, the gentleman who did the talking, Mr. Hill, took this tumbler up in his hand, sat at the table, held it in his hand, moved it around, and shook it as much as was convenient or not, just as it came handy, paid no attention to keeping it still, talked into it in a steady voice, and there was no trouble in transmitting.

About 1881 Hunning, in England, invented this improvement in telephone transmitters. He found that it was impossible with the instrument held in the horizontal position to get any speech, but if you hold it perpendicular, and put in granular powder like sand, and, when it gets packed, occasionally tap it with the fingers, you have got a first rate transmitter. And he patented that.

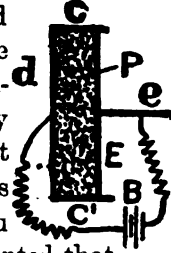

Drawbaugh never conceived of tipping that up so as to make it talk, and shaking it and using coarse powder. He says he kept it horizontal. When we got to Philadelphia, they changed the powder of the New York test into powder which was a little granular, which is of some importance, and then took the instrument and tipped it up and got in substance Hunning's conception,—his idea, inside of that tumbler, and then the thing talked.

If you took the instrument, not as Drawbaugh described it, but altered by putting the Hunning's invention inside, changing it so that it conformed to Hunning's idea, by using coarser powder and tipping it up that way and tapping it, it would make a first-rate speaking-telephone. That is what the defendants did in Philadelphia.

Drawbaugh never had that notion, and swears he used his tumbler in a way which excluded that notion.

In his original that he produced he had these rude plates.

He never had a carbon-holding box around it, and if he did not, he could not have tipped it up. But even if he did, it is impossible with plates having those rude jagged edges to make a tight box that will not spill out fine granular powder when it tips up edgewise.

**Daniel Drawbaugh.**  
**INVENTOR, DESIGNER**  
**and**  
**SOLICITOR-PATENTS.**  
 Also Models Neatly Made To Order.  
**Eberly's Mills,**  
**Cumberland County, Pennsylvania.**

**Dan'l Drawbaugh,**

**I** **NVENTOR**   
**THE FOLLOWING PATENTS.**

Stave, Heading & Shingle Cutter.  
Barrel Machinery.

**STAVE JOINTING MACHINE,** Many in use.  
Tram & Bed-staff for leveling face of Millstone.  
Blow and Driver for running Millstone.  
Nail Machinery for Feeding Nail Plates.

**PUMPS, ROTARY & OTHERS.**

*Hydraulic Ram.*

**THE DRAWBAUGH** Rotary Measure-  
ing Faucet. very extensively used.

**CARPET RAG LOOPER**-- A little  
device by which rags are looped quick and firm,  
without Needle or Thread.

**ELECTRIC CLOCK.**

**M** **AGNETO ELECTRIC**   
**MACHINE,**

For short line Telegraphing. Fire Alarm.  
and Propelling Electric Clocks. It can be  
applied to any form of Electric movement.

Gives entire satisfaction **USING NO**  
**GALVANIC BATTERY.**

**For SIMPLICITY it has NO RIVAL.**

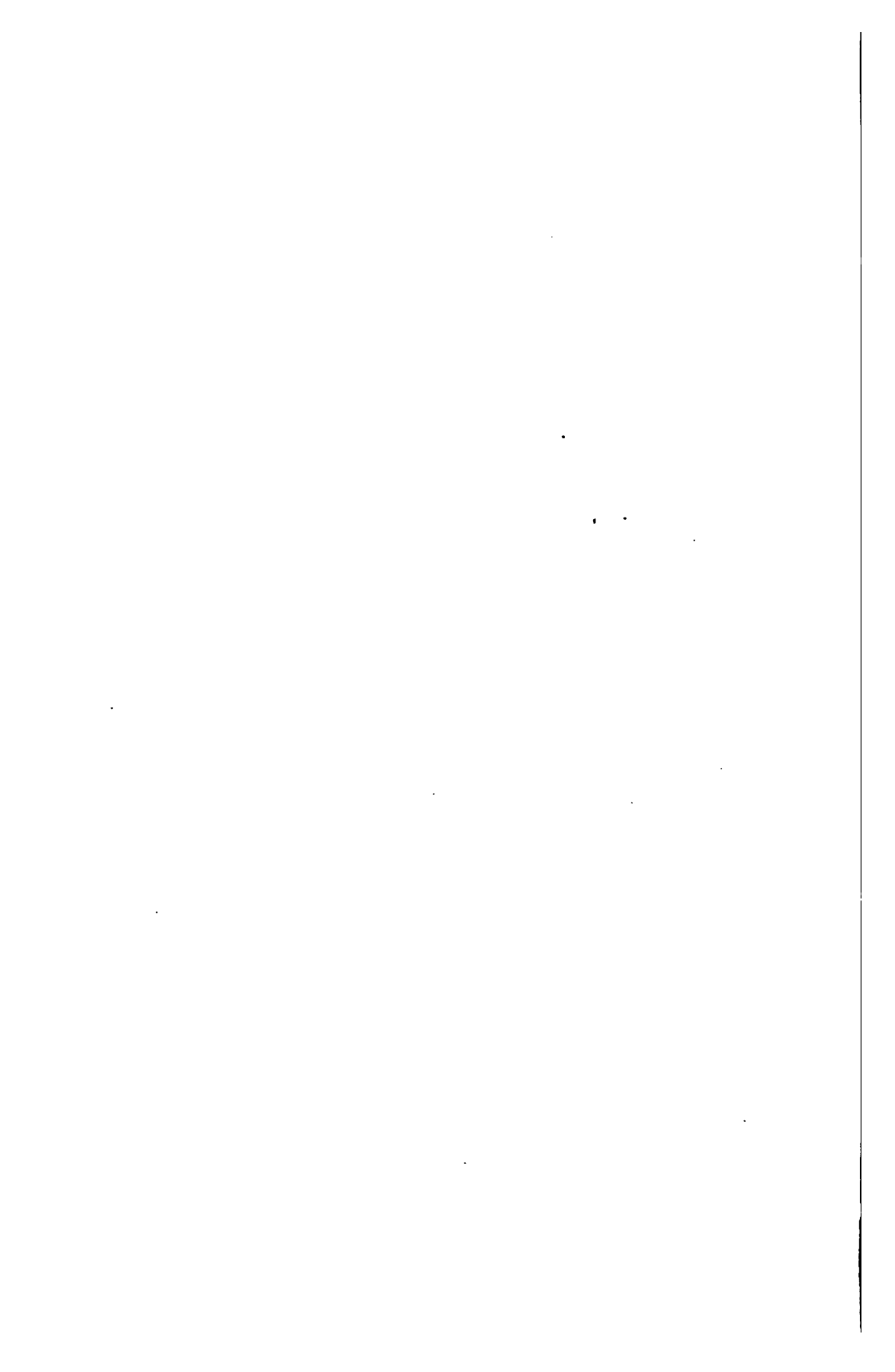

## Argument of counsel.

But the instrument used in Philadelphia had that plunger piece quite tight, so that when they tipped it up edgewise it wouldn't run out.

The result, then, is that the pair "F" and "B," sworn to by more witnesses than all their other instruments put together, cannot do what the witnesses profess to recollect.

I now come to the instruments "D" and "E." There is no doubt that those are good instruments enough to destroy any telephone patent. They will talk. The only question is their date.

Drawbaugh says he does not know in what year those instruments were made, and out of the four hundred witnesses they have called, they only found seven who pretend to have heard speech through that pair of instruments before the Bell patent. More than half of their witnesses swear to the tumbler and tin can.

The appearance of the tumbler and tin can at Drawbaugh's shop at any time as exhibition instruments, is perfect proof that the alleged better instruments did not then exist.

If, after the Bell patent he was using the tumbler and tin can habitually in his shop as the best he then had, it is perfectly certain that he did not have those pretty little magneto instruments "D" and "E," did not have those two refined vase-shaped microphones G and O, did not have the Blake transmitter "H."

Defendants' answer says: "That Drawbaugh for more than ten years prior to the year 1880 was miserably poor, in debt, with a large and helpless family dependent upon his daily labor for support, and was from such cause alone utterly unable to patent his said invention, or caveat it, or manufacture and introduce it upon the market."

All those allegations of the answer, important as they are, were displaced by his own testimony.

It is not a case where there was poverty, which prevented him from reducing his invention to practice.

## Argument of counsel.

(Counsel here stated Drawbaugh's history and testimony as to his inventions.)

It was part of the story of Drawbaugh, that it was impossible for him to draw a specification for a caveat.

Afterwards we found this card, one edition of one hundred and fifty of which was printed in 1874, and another edition of one hundred and fifty more was printed between 1874 and the fall of 1876; in which he holds himself out as a patent solicitor and model maker.

If he held himself out to the community as a solicitor of patents, he can hardly stand up and say that he was grossly incompetent to draw a caveat for his own invention.

They took the depositions of two hundred and fifty witnesses after that; but they never put Drawbaugh on the stand to explain how he could have left the telephone out of that list, if he had had it.

In 1878, nearly two years after the Bell patent, Drawbaugh began to be talked of as a man who was *then* making telephones.

In 1878, the newspapers mentioned him as a man who was making *improvements* in telephones.

There were four, five or six articles in 1878 which spoke of him as an *improver* of the telephone.

He went to the telephone office in Harrisburg, in the spring of 1878, and carried instrument A with the mouthpiece off one side, said, "Let me look at your telephone."

They showed him the "Phelps's snuff-box" form.

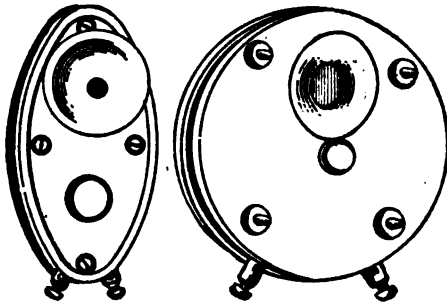

He placed his "A" alongside of it. "Is this patented?"



## Argument of counsel.

said he. "Yes." "Then mine is most too like it:" instead of his saying that the thing they had had for only six months, he had had in use four or five years.

At that time, he had exhibited his nail machine, his faucet, and his pump; he was then mentioned in the newspapers as an exhibitor. If he had wanted to make a sensation at that State Fair, why did he not take over the speaking-telephone?

If he had got it into the papers it would have been known; and there would have been no mortal use for Bell being born, after that had been done. The speaking-telephone would have been given to the world, if he had done that, ten years before Bell's patent.

The State Fairs where he exhibited his other things, but no telephone, were in 1868 and 1869. These improved instruments, he alleges, he had in the summer of 1876, and some of his witnesses testified that those improvements were in his shop; that, in the summer or fall of 1876, they saw all of them.

The dates which they allege in their brief are that these L, M, G, O, were made in the beginning of 1876, just before the Bell patent; and this, the Blake transmitter H, in the summer of 1876.

The *Baltimore American*, of November, 1878, is the only paper in existence which refers to Drawbaugh as having thought of the subject of speech, or of a telephone, or of the transmissions of sounds by electricity before the Bell patent.

But his poverty, says the article, prevented his bringing even the experiments that he made to a successful result. That states him as a man who experimented, not for speech, but for sounds, through what is known as a phonetic telegraph.

The value of the testimony of a large number of our witnesses does not rest upon either mere recollection or veracity. Their whole course of conduct, as well as Drawbaugh's course of conduct, is consistent with our belief that his story is untrue, and inconsistent with the story itself.

## Argument of counsel.

Mr. EDWARD N. DICKERSON, for the American Bell Telephone Company :

The defences in the Dolbear case are : That Bell has invented the only way in which it is possible to transmit speech; that Dolbear does not infringe, because he is using one of the old, well-known kinds of receivers for sound, which Bell never used, and which is not an equivalent of the receiver of the Bell patent; and that Reis was the first inventor.

The defences in the Molecular case are: That Bourseul and Reis described the invention of Bell in circumstantial detail, so that any one can read it out of their descriptions; and it needs, therefore, no invention to do it after those full explanations have been given to the world; that the interpretation of Bell's patent ought to be such as to secure Bell in the exclusive enjoyment of that tin and bladder contrivance on the table, known as Fig. 7 of the patent; but that he ought to be confined strictly to that; that such an interpretation secures what Bell invented, and enough of what he discovered to enable him to work his invention, while not excluding other inventors from access to the universal storehouse; and that the reason why Reis' invention did not get into public use at all was, that Reis freely *gave* it to the world; and that Bell never thought he invented a telephone; that Fig. 7 is not a telephone, never was meant by him to be one; that it is in fact a "*multiple telegraph*," and never was meant to be anything else.

*The Overland-Drawbaugh-combination defence.*

It is inconsistent with the theory of Drawbaugh to admit that Reis was the inventor of the telephone; because, if he were, the patents that Drawbaugh and Company are going to have by Act of Congress, when this Court decides that he was the American "Faraday" who did it, would be of no value; for the Reis publications would have destroyed them. And therefore it is necessary for them to say that Reis did not invent the speaking-telephone; that he never had that

## Argument of counsel.

invention, but only had a musical telephone. But they say that Drawbaugh did invent it.

They also assure us that Gray invented it ; but he invented it after Drawbaugh did, and before Bell.

The combination also sets up that Bell did not invent at all ; but being a man, as they say, of "transcendent abilities," he devoted his talents with great success to a miscellaneous variety of felonies, in consequence of which he came out with a first-rate, highly scientific description of a telephone in his pocket, and upon that he succeeded in imposing upon the world.

In the Clay case, the defences are : The Varley patent and that it was a speaking-telephone ; and that there is no such company as the Bell Telephone Company. There is another part of that defence—that is the testimony *in pais*. We had supposed that the publications abroad were all that in law could constitute a defence ; but in Germany were found seven persons who were willing to say that the telephone of Reis was a talking-telephone in 1860-61.

So they took out a commission in the Overland case (and it is before you, and made a part of the evidence here), subject, of course, to objection, and sent that abroad ; and they managed to get the depositions of five or six of these German persons who knew that Reis was the inventor of the telephone. That was all ruled out by His Honer Judge WALLACE as incompetent, as we think it obviously is ; and that ruling is before Your Honors to pass upon here on appeal.

That is the testimony which is to supplement the publications.

The Gray defence has grown into immense proportions. It is the last vain hope of the infringers.

The Western Union, in the Dowd case, set up that Bell had "surreptitiously obtained a patent" for that of which Gray was "the first inventor, who was using due diligence" in the Patent Office to procure a patent ; and the whole story

## Argument of counsel.

of this caveat was set out in the answer in the Dowd case in 1877. Gray was a party to that Dowd litigation. Dowd was a name only—the real party was the American Speaking Telephone Company, and Dowd was their agent. That company was to be composed of three parts: Gray and his partner, S. S. White, of Philadelphia, were one part. One-third of that company was designed for Dolbear, the other first inventor, but they kicked him out.

After the eviction of Dolbear, the Gold and Stock Company, a subordinate of the Western Union Company, owned two-thirds of that stock, and do so to this day; and Gray and his partner owned one-third. After the Bell patent was established by the judgment against Dowd, that company got one-fifth of the profits of the Bell Company for the patents and property surrendered by the Western Union Company, and its stock became valuable, and Gray sold four or five hundred thousand dollars' worth of that to the community, and got his money; all founded upon the fact that Bell was the first inventor, without which it was worthless, and which fact he is now trying to destroy.

Gray went on the stand and told his story, fighting for that one-third of the business of telephony in the United States; and his story was that the first conception he had of a telephone distinct enough to mention to any one, or to put upon paper, was on the 11th day of February, 1876, which was twenty-two days after the Bell specification had been sworn to, and was waiting in the hands of Mr. Pollok to be filed. He said that he then made a sketch of his idea, and gave it into the hands of his very able and respectable counsel in this town, Mr. Baldwin, to file as a caveat; which Mr. Baldwin did, on the 14th day of February, 1876, on the afternoon of that day, the Bell application having been filed in the morning of that day.

After hearing Bell's telephone talk, Gray concluded that he would try his conception which he had got on paper; and so he made one, but he could not get anything through

## Argument of counsel.

it. That is the only time that that experiment was ever tried, from that hour to this.

Gray tried that transmitter himself at Philadelphia and it would not talk; and he has also testified that Bell was the first inventor of the magneto telephone like Fig. 7.

The magneto telephone, of which Gray knew Bell was the sole inventor, figures as Gray's Fig. 5 of his application.

The usual term for the Bell invention was "a speaking telegraph" in those early days, and so it was called by Gray and others generally. It was not called a "telephone" until some time after the patent.

(Counsel here presented the correspondence between Gray and Bell, in 1877, after the issuing of the Bell patent and read a letter from Gray, recognizing Bell as the inventor of the speaking telegraph.)

Gray's application for a patent is for the broad art of telephony and contains three plates. The first plate is for the details of his caveat drawing; the second is for his caveated machine in operation; and the third is for the Bell magneto telephone.

It differs from this Fig. 7 of the Bell patent only in the circumstances that the converging cones are similar at both ends, and of slightly different shape; whereas, in Bell's patent one is a tapering cone and the other flaring.

(Counsel here reviewed the evidence as to the alleged fraud on Gray, in copying from his caveat the principal alleged discovery in Bell's patent, and replied to the charge that a part of Bell's specifications were taken from such caveat.)

When Bell conceived this idea of using true "undulatory" currents, that were to be made in unison with the sonorous vibrations of the inciting cause, that was a complete new revelation. It came like a flash to him. That application of the undulating method forms the greater part of his patent.

Go back with me now to the history of this litigation. Beginning with the Dowd case, it was pleaded that Gray

Argument of counsel.

was the inventor; that Bell had "surreptitiously" obtained his patent for that which Gray had invented, the caveat for which was on file; that the Commissioner of Patents had unlawfully decided the question of dates,—it is in the amended answer in the Dowd case, and it all broke down upon the testimony itself; for whatever might be true, Gray admitted that the first he ever did was, on February 11, 1876, to make a sketch. That ended the question, because Bell had sworn to his application on the 20th of January before; had conceived, invented it, written his application for it on October of the year before; and therefore it was entirely important what Mr. Gray did or did not do after that time.

But by degrees this monstrous calumny began to grow. At first it was confined to that legal plea, and the evidence accompanying it; but it began to grow in dimensions until, like a tornado, it was sweeping through the air and carrying everything before it, and it is claimed that Bell had committed a monstrous fraud on the office; he had bribed the Examiner; he had stolen the Gray caveat; and that grew into immense proportions. Whoever has read the newspapers in the last two or three years can hardly see one where that story is told, and it came ultimately to assume that form in the Courts. It has been set up in lawsuits, and published upon the wings of the wind to the uttermost parts of the earth. It came to trial in the New Orleans case and the whole gang were witnesses, and in that case the Court decided "The fact that Bell's invention certainly dates from January 20, 1876, and that it covers a speaking telephone, transmitting articulate speech by means of an undulatory, oscillatory, or vibratory current of electricity, renders it unnecessary to pass upon the evidence relating to the tergiversations and claims of Gray; the alleged frauds of Bell in advancing his application for a patent; the illegal conduct and conflicting statements of Examiner Wilbur; and many alleged vices and irregularities, the evidence of which forms the bulk of the record, and apparently the main defence in the case.



## Argument of counsel.

“At the same time, it is proper to say that in all the evidence we have found nothing that shows that Bell has done, or caused to be done, anything inconsistent with his right to be called an honest man, with clean hands.”

The hypothesis in that case was that Mr. Bell had got the Gray caveat in his patent by these formal amendments, made regularly after the 27th of February. But there stood his application, with all of what they say is the Gray caveat in it, sworn to on the 20th of January, and filed on February 14, and declared by the Examiner on February 19 to contain the substance of the caveat, before he ever amended his application in respect to these immaterial things.

He is entitled to his patent if he is the first inventor; and if he has committed any of these crimes he must be punished for them by law; but you cannot confiscate his patent for that reason; there is no such punishment for crime in the statute.

The whole of the Gray caveat was in Bell's specification of the date of January 20, three weeks before the Gray caveat existed.

According to the latest and wonderful theory, Bell proceeded to mutilate his own record by interlining into it words in pencil, which were not there in the fair-written ink application.

If that application had had in it these interlineations, they would have appeared in the patent; just as those amendments that were lawfully put in do appear in the patent. Mr. Edmunds, counsel also for the Drawbaugh and Overland Companies, and Mr. Hill's leader, said that if there was a fraud “It was without the co-operation of Mr. Bell.”

In his interference proceeding with Gray, in his preliminary statement on this record, Bell told the story exactly as it was—that he made his first liquid transmitter in Boston on March 10, 1876, three days after his patent; when all the while, according to this ingenious hypothesis, he was defrauding Gray.

TELEPHONE CASES.

[Sup. Ct.

Argument of counsel.

Mr. Gray subsequently wrote him that letter which I have  
, containing these words, "I gave you the credit for the  
ing feature of the telephone."

The evidence as to the George-Brown specifications was  
reviewed by the counsel.)

After Mr. Brown had got his specification, there occurred  
several devices that are now described in his patent;  
liquid transmitter, vibrating the plates of the battery,  
those other different things now in the patent.

These amendments made to the American copy in Bell's  
did not get into Brown's papers in Canada, of course.  
When Brown came to New York they were not inserted.  
During all these years of litigation it never has been sug-  
gested by or to a human being, until it was done at this  
bar, that the Brown transaction had anything to do with  
the faith of Professor Bell.

It is all supposed, and it is perfectly true in law, that if the  
amendments to the American specification were not the  
patent would be just exactly as strong in law as it is  
with them in; because that Fig. 7, in connection with the  
specification, discloses the whole method,—a truth which  
everybody swears to,—and all variable resistance devices and  
the detailed plans, alternative and equivalent forms. Mr.  
Gray and other witnesses all swear they are plain equiv-  
alent. Therefore, it was of no consequence in a strict legal  
sense whether they were mentioned or not in the speci-  
fication.

When George Brown came home and Bell got those papers,  
he brought them to the Patent Office, and laid them there before  
Mr. Gray, with whom he was in interference.

Every certified copy of Bell's specifications known to  
the court is just like the present paper. That is physical proof  
that these passages were all there February 14, 1876, when  
the paper was filed. We produce record proof which is con-  
clusive.

Now we come to the McDonough case, which has not been





## Argument of counsel.

touched orally on our side nor on the other, but is set out fully in both briefs. McDonough invented what we call the tambourine telephone. It is the same in substance as Reis'.

McDonough was a wholesale manufacturer of furniture in Chicago. Having a little taste for science, and having got hold of the Reis publications, he thought he would make one of those things himself; and he modified it in respect to the form of a triangular hopping piece, and he modified the receiver by using a diaphragm on it like Bell's. Having done that he applied to the Patent Office for a patent on this thing, after the Bell patent was out, and called it a "teleloge," or far talker. The Patent Office rejected him, and said: "You can't have a patent for that, because it is anticipated by Reis, and it is not a talking telephone anyway."

It was April 10, 1876, when he made application; and the Patent Office rejected him because he was anticipated by Reis, *quoad* the whole machine, and by Bell *quoad* the receiver.

After he was rejected he attempted to amend his specification by writing Bell's invention into it, and Reis out of it, but was prevented by the Office.

He did not have a talking telephone.

McDonough then formed the usual telephone company, with several millions of stock; not to use his apparatus, of course,—that was a Reis machine—but to use the ordinary telephone; and he was then sued in the Courts and enjoined.

Then there is the Varley patent, which is claimed to have anticipated Bell. I will ask attention for a minute to another way of putting into your minds the conception of a current of electricity.

An undulatory current is represented by a curve like a wave of the ocean.

What is meant by the words "current flowing" is, that the entire conductor or line-wire is charged with electricity from end to end.

In an "undulatory current" there is no interruption at all,

## Argument of counsel.

and the line is *always* charged with electricity; but the *degree* of charge varies from instant to instant, and that variation is represented by the rise and fall of the curved line above a certain base.

There is no such thing in electricity as a *flowing current*, or an onward movement of matter.

There is an *impulse* transferred from molecule to molecule all the way through, like a jelly that is shaken, but nothing travels from end to end.

The transmission of electricity is much like the transmission of light through the ethereal medium.

Then again, there is no such thing, excepting conventionally, as a "*to-and-fro current of electricity*." We use those terms for convenience; but we know what they mean, and that they do not mean an actual flow of an actual current either way.

(Counsel here replies to attacks on Judge WALLACE's decision in Drawbaugh case.)

The principles of law which govern the Drawbaugh matter are, that in any case where a patent is assailed, particularly by a stale claim made four years after the patent has been bruited all over the world, the assault must be maintained beyond any doubt, and that if there be any doubt created, that doubt at once destroys the defence. Or, as the Courts put it, "To create a doubt is to resolve it in favor of the patent."

Whatever doubts there may be in this confusion of testimony we are not to be called upon to clear up and resolve.

Doubtful defences enough can be raised; but they cannot overcome the *prima facies* of the patent granted upon examination.

We have shown you that in respect to the time, many of these witnesses are grossly mistaken.

I propose now to show you that Drawbaugh was a charlatan and a dishonest imposter, and that he was surrounded by a gang who used him for the most dishonest purposes.

## Argument of counsel.

(Counsel here reviewed the evidence as to the Drawbaugh inventions and claims, and, after a long examination of the facts of the case, spoke of the treatment of Mr. Bell.)

Mr. CAUSTEN BROWNE, for Dolbear *et al.*:

The Dolbear Company's defence to the Bell Company's suit is different in kind from the defence of any other appellant here. It is this: That the Dolbear method and apparatus do not infringe; that they are based upon a discovery of Mr. Dolbear as original and as fundamental as that of Bell; that he, as well as Bell, started from first principles to deal with the problem of electrically transmitting speech; that Bell proceeded by one road, while Dolbear proceeded by a road discovered by himself; and that, except in reaching the result of electrically transmitting speech there is no resemblance between the two methods or the apparatus employed by the two inventors, so far as regards any patent protection enjoyed by Bell.

All the defences of other appellants may fail, and yet the defence of the Dolbear Company remain untouched.

No construction of Bell's patent will cover the Dolbear method as an infringement, except a broad construction *for the use of electricity for the purpose of transmitting articulate speech.*

A theory of invention dangerously broad was asserted by the counsel for the Bell Company. The 5th claim of the patent is limited by the expressions: "as herein described" and "substantially as set forth."

I suppose that one of these refers to the description of "electrical undulations," and that the other refers to the description of the way in which those undulations are produced and used.

Causing the sonorous motions of the air to bring about corresponding electrical changes, which electrical changes bring about sonorous motions of the air, like the first—is the patented invention, as the appellees contend.

Mr. Justice GRAY says, delivering the opinion of the Court

## Argument of counsel.

in Spencer's case, that Bell discovered a new art, that of transmitting speech by electricity, and that his patent *is not* limited to a particular form of apparatus, but includes the process or method.

This, while denying Bell a patent *in terms* for the use of electricity to transmit speech, gives it to him *in substance*.

Dolbear as a witness is attacked upon two grounds. The first is that he said in his testimony about the working of the Reis instrument something which contradicted what he had said in his published book. Now, that is a mistake.

In these two cases the fact is that Dolbear, the witness, was speaking about two different instruments, and the alleged contradiction in the testimony of Dolbear disappears when you come to see what he is talking about.

Then again he wrote a letter to Bell in 1877, which may be fairly construed as an offer to keep back from the public a book which he was about to publish upon the telephone, if Bell would recognize his claim to the invention of the use of the permanent magnet. This claim of invention Dolbear believed to be just. Nevertheless I agree that that letter ought not to have been written.

Dolbear was unfortunate in having counsel at that time who did not see, any more than he did, the impropriety of writing it, for the letter states that he had written it with the approval of his counsel.

Two years afterwards the road to the new use of electricity which constitutes Dolbear's invention, was opened to him, and then the invention was made which he and his assignees now claim at your hands the right to practice.

I claim full consideration for the evidence of Dolbear upon the point I stated a little while ago—that the correspondence of electrical changes with the sonorous air changes made in speech is that in which the *electrical transmission of speech consists*.

It was a physical truth, known among scientific men and practically applied, that the electrical transmission of *sound*

## Argument of counsel.

*in general* consisted in the production, in the line conductor, of electrical changes corresponding to whatever sonorous changes were made in the air by making the sounds, and the utilization of those electrical changes to produce sonorous changes in the air like the first.

Reis certainly transmitted *some* of the sonorous air vibrations made by speech, by having them produce corresponding electrical changes in the line conductor, which electrical changes produced sonorous air vibrations like the first.

The air is moved in speaking by way of vibration, the air particles moving to and fro in straight lines only. Every movement of air particles to and fro is a vibration, relatively long or short. In speech, every air particle moves or vibrates in obedience to a combination of impulses. It is the mixture of fundamental vibrations and overtone vibrations which gives what we call quality. Every vibration has some pitch, and some amplitude.

Condensation and refraction mean variations of pressure produced by movement of air particles to and fro. It can mean nothing else.

There is a scientific article, published in 1863, in which Reis's work up to that time was discussed, showing that the problem was there stated, namely: *Let all the sonorous air vibrations of speech be electrically represented; let them all be translated into electricity; let there be electrical changes corresponding to the sonorous air vibrations, and let them reproduce sonorous air vibrations like the first; if you can do that, you will transmit speech.*

The construction which was given to the Bell patent in the Court below, and which is pressed against us here, is that doing that anyhow is patented by Bell.

I read from a scientific writer of 1863, in a commentary on Reis, to show that the problem, the statement of which is called Bell's patented invention, to-day, was as well recognized then as it is now. Says the writer: "*If we succeed in transmitting with the galvanic current the oscillations of a sound-*

## Argument of counsel.

*ing body to a distance, so that there another body is put in equally rapid and, in respect to each other, equally strong oscillations, the problem of 'telephony' is solved."*

The writer continues: "*For then exactly the same phenomena of waves are called forth on the distant points as the ear receives at the place of origin; therefore they also must make the same impression.*"

The writer tells you if you can find a way to transmit upon the galvanic current these changes, absolutely and proportionally, then you can transmit speech.

Bell solved that problem, and that was *all* he did.

The decision of the Court in *Tilghman v. Proctor*, seems to me to be quite conclusive of this case. The opinion says, upon page 729 of the report in 102 U. S. [13 Am. & Eng. 29], that *the claim of the patent is not for a mere principle*. The chemical principle or scientific fact upon which it is founded was not discovered by Tilghman. He only claims to have invented a particular mode of bringing about the desired chemical union. *This is a process*.

In the present case also, there is a principle or scientific fact involved. If you would transmit speech, you must have the electrical condition of the wire vary with the varying conditions of the air brought about by speech, and produce again like varying conditions of the air. This is the alternative statement of transmitting speech by electricity.

What was the method invented by Bell for solving the problem? When he took his patent, there was but one agent that had ever been used for variably attracting any object so as to make it vibrate and beat the air and give out audible sound. That agent was *magnetism*. There was but one practical use to which electricity had ever been put for the purpose of so causing a body to vibrate and give out audible sounds; and that was as *a flowing current making an iron core an electro-magnet*, the variations of current strength causing like magnetic variations. Bell found a way to get electrical changes, corresponding in form to the sound-waves, in the

## Argument of counsel.

current traversing the coils of an electro-magnet, and so to produce corresponding variations in the magnet, and corresponding vibrations of a receiver armature.

Electrical charge or tension may be brought about by rubbing an object, sealing wax for instance. This is the property which has been *reduced to the service of mankind for the first time by Dolbear.*

The power of a body charged with electricity to attract anything, though known for two thousand years to exist, had never been put to any practical use in the arts when Dolbear made his invention; certainly it had never been supposed that variations of electrical attraction could cause corresponding vibrations of an armature.

Dolbear's receiving apparatus is properly enough called a condenser, because in structure it generally resembles the old condensers. That is to say, it has two plates electrically insulated and charged. But the operation is radically different from that of the old condensers. No operation of vibrating either plate by variations of electrical charge was contemplated or performed in the case of any of the old condensers.

In all these old condensers the elements were placed close together, with a non-conductor (I do not mean air, but a solid non-conductor) interposed and closely fitted between them, so that the electricity might be condensed, which non-conductor prevented any practical vibration of either of the elements.

In the Dolbear receiver, on the contrary, one of the plates is held firmly so that it cannot vibrate, and the other is held so as to be free to vibrate according to the variations of electrical charge, and beat the air and give an audible sound; the two plates being separated by a body of air, so that no current can pass. Here was a change in construction, designed to produce a new operation, for a new purpose, without which change that operation could not be performed nor that purpose answered.

It will not be denied that if Reis had known that to get

## Argument of counsel.

variations of magnetism at his receiver exactly corresponding to the sonorous air motions of the speech uttered against the transmitting membrane diaphragm, he must keep the circuit closed, and had so adjusted his means of making contact between his electrodes that the vibrations of the membrane would not break the circuit, but only vary the current strength, and had so used the instrument, he would have had Bell's method, and substantially his apparatus. That is just such a change as Dolbear made in the construction and use of the old condensers. He altered their structural arrangements a little and thereby altered their operation enormously.

To hold one element of a condenser still, so that it shall not vibrate, and suspend the other so that it shall vibrate, and then make use of its vibration according to variations of electric charge, was wholly and absolutely new. No such instrument existed. No such use of any instrument had ever been proposed or supposed to be possible. It cannot be said, with any show of reason, that any equivalent for it was found in any of the old condensers.

For the purpose of transmitting and reproducing any sound by variations of electrical attraction, causing vibrations of any armature, nothing in the construction or use of the old condensers furnished a known substitute for the magneto receiver.

Dolbear's discovery of the capacity of variations of electrical attraction to make an armature vibrate accordingly, was accidental.

He is not now setting up any anticipation of Bell; only claiming the right to freely use a distinct method and apparatus of his own, based upon a distinct discovery of his own.

When he showed it to scientific men, without exception they expressed their astonishment at hearing that variations of the electric potential of a terminal plate could practically produce any sound vibrations of an opposed diaphragm comparable to those produced by the varying attractions of an electro-magnet.



## Argument of counsel.

It is, I submit then, the truth that Dolbear, like Bell, has made an application of the laws of nature which no one had ever made before, which no one had thought of before, by an instrument which did not exist before, the *result only* being the same—that is to say, the electrical transmission of speech; or, in other words, making speech bring about corresponding electrical changes on the line conductor, which in turn bring about corresponding audible vibrations at the receiving station.

But the appellees say that there are flowing currents in Dolbear's method. In a sense this is true; but not in the sense of the Bell invention or of the Bell patent. The current in which the electrical changes corresponding to the sonorous air changes are produced is the current *on the line conductor* extending from the generator through the transmitter, through the receiver and back to the generator.

These currents are, in Bell, the well-known circuit currents converted into magnetism by traversing the coils of an electro-magnet at the receiving station. In Dolbear they are merely the currents which move to or from the receiving plate, which is thereby variably charged from instant to instant, so that it may exert its variable electrical attraction, *there being no magnetism at all*. The currents in the two are thus seen to be *essentially different in character, purpose and result*.

The currents of Bell do their described work of transmitting the speech to the receiving station and there delivering it, by virtue of flowing, and only while they are flowing through the coils of the receiving electro-magnet, whose corresponding magnetic variations vibrate the receiving diaphragm. All that vibrates the receiving diaphragm in Dolbear is the variations of charge of electricity in his attracting plate.

Neither Bell nor Dolbear could patent the correspondence of the electrical changes with the sonorous air changes, because that was the known law of electrically transmitting sound.

Reis tried to transmit speech by variations of current

## Argument of counsel.

strength in an interrupted circuit. Bell tried, and succeeded, in transmitting speech by variations of current strength in a constantly closed circuit. Dolbear transmits speech by variations of electrical attraction, using no circuit, and no flowing current for that purpose at all.

He who transmits speech by Dolbear's receiver, operating by variations of electrical attraction, uses Dolbear's method and apparatus, *whatever else he does as a separate matter*. And he who only transmits speech through Bell's receiver, using *magnetic variations* to produce the vibrations of the receiving armature, does not use Dolbear's method, but uses Bell's.

But if anything in the description of the method of, and apparatus for, transmitting speech is *characteristic of* and *essential to* Bell's invention, it is this: That the current from transmitting station to receiving station, on which the required electrical changes are to be impressed, is a current traversing the coils of an electro-magnet, and that the operative power for vibrating the receiving diaphragm is the varying magnetism so produced in that electro-magnet.

No such current is employed by Dolbear for transmitting speech. No magnetism is used by him for reconverting the electrical changes into sonorous air changes. His method is new, because based upon a mode of using electricity not at the time of Bell's patent known to be practicable, and is substantially and fundamentally different from Bell's. His apparatus is new, and it is essentially different from Bell's, for the same reason.

The only resemblance between Bell and Dolbear is that each produces, somehow, electrical changes in the line conductor corresponding with the sonorous air changes made by speaking, and reconverts those electrical changes, somehow, into sonorous air changes at the receiving station. But this cannot be validly patented by Bell (even if his specification would bear such a construction) because it is, under another form of words, patenting the use of electricity for transmitting speech; and this, it is agreed, cannot be done.

## Argument of counsel.

Mr. WHEELER H. PECKHAM, for the Molecular Telephone Company :

Reis conceived the idea that quality might be or must be transmitted in order to produce speech. He knew and expressed what quality was.

The first electrical machines of which we know were magneto machines. Among the earliest were the Gausse & Weber machines, as they are called—the earliest telegraphic instrument. It was a magneto machine, and it was followed by a number of others.

Varley first gave to his currents, so-called, the word undulatory.

Wheatstone's device, a printing apparatus, operated upon the same principle—the magneto principle.

There is another method of effecting electrical work, by using a battery current and then putting a device in the wire through which that current runs, and making or breaking, or changing the current. Those two methods of effecting electrical work were well known at the time Reis made his inventions.

When Reis came to make his invention he adopted the constant current, the voltaic current, and his method was by interrupting to operate upon that current by means of a diaphragm actuated by sound-waves.

Bell, at a very much later period, speaks of an intermittent current as one which was pulsatory.

The *Industrial Gazette* says: "Successful experiments in telephony were made in 1861 by Reis," so that it seems not impossible to carry on conversations at miles distance, and even convey the voice itself, with its peculiar undulations.

Reis used the voltaic current, and subjected it to interruptions or variations by means of the vibration of a diaphragm, caused by the action of sound therein and transmitted to a receiver, including the sounds of the human voice, and produced musical notes; and all the Reis articles speak of the production of speech.

## Argument of counsel.

Beyond that we have the testimony of a series of witnesses who say that at the time when Reis himself was operating, and when others operated it, that it did produce speech.

It does it far better than Bell's device (Fig. 7) ever did until after several years had elapsed, and the world had learned by constant practice how to produce instruments that would transmit speech, because the best that was ever said of Bell's instruments until the year 1879 was that they produced a faint muttering, and nothing else.

We emphatically claim that the evidence does show that the Reis telephone did produce speech, and that it was intended to produce speech, and that whatever be the theory or whatever be the explanation by which, and through which, speech is produced, that theory and that explanation were adopted and existed in the Reis telephone.

It was done to a far greater and better extent than Bell did it, prior to 1878 or 1879, by the instruments described by Fig. 7 of the first patent.

The moment you put an improvement in mechanical construction in the shape of a receiver, like the Bell receiver, this Reis transmitter will talk.

If you put the microphone with the carbon points in place of the old Reis transmitter and attach it to that Reis-Legat receiver, that will talk.

A simple improvement in the mechanical construction of the instrument, and this Reis telephone springs up into an active, strong, vigorous, practical instrument, and commercially has taken the place that otherwise would have been occupied by Bell's invention at the present day.

If Reis gave the wrong explanation, that does not affect the fact that he has produced an instrument and device operated by sound-waves made by the voice, which will convey what a person speaks into the instrument—precisely the same thing in the way of transmitting the vibrations to the ear that is in the receiving instrument of Bell.

There is a fallacy in the statement of Bell as to the opera-

## Argument of counsel.

tion of his instrument. Bell says that he undulates this voltaic current, but he did not.

Reis took a voltaic circuit; he had a method of working that circuit by means of air-waves—sound-waves. That is the great invention. That is the initial step; that by means of the voice you can speak to a diaphragm, and have that diaphragm affect a voltaic circuit or affect a current of electricity, so that it will produce similar variations at the other end and be heard. Reis did that.

Varley came afterwards, and he adopted the magneto method again and he transferred sound.

He did it in three ways: First, by making and breaking a primary circuit; second, by vibrating his transmitter by the air; third, by revolving a wheel, upon the periphery of which were bar magnets, before the poles of an electro-magnet.

All those things were before Bell came. Now, what did Bell do? Bell, adopting the magneto method of effecting electrical results, *took the apparatus of Reis and adapted it to that magneto method. He did not do anything else.*

By the term "method" in the 5th claim of his patent, Bell meant *the magneto method and nothing else.*

Bell's letter of August 14, 1875, gave simply the idea of telephonic or telegraphic action—telegraphic work—*by means of the magneto current.* (Mol. Rec. p. 1618.)

He did nothing after his letter prior to the taking out of his patent, in the way of experiments, other than one, or two, or three experiments made in the early part of July, and which resulted in merely obtaining a sort of muttering effect. The draft specifications and claims of Bell, and his George-Brown specification or copy application, speak of a production of or causing electrical undulations which, by the terms of the specification, is necessarily confined to the magneto method, because the specification says that there is no other method.

And then when we have by some means, whatever they may be, whether fair or unfair, fraudulent or honest, new

## Argument of counsel.

thoughts from Gray or from himself, or whatever may be the reason, the idea suggested to him and put into his patent that electrical undulations can be caused by the variations of the resistance of the circuit, we find a claim put in to correspond to that; but we do not find any change or any variation whatever of the 5th claim.

There is not in that patent to be found anywhere, from the beginning to the end, any suggestion that there is any other method of causing electrical undulations by sound-waves than the one which is pointed out and illustrated by Fig. 7. All prior methods of producing electrical undulations have reference to, and are involved in, the production of telegraphy. Some of them are ways that it is absolutely impossible to use in connection with the production of sound-waves; as, for instance, the vibration of a wheel with magnets on the periphery before the poles of the magnet.

We claim that Bell's patent should be construed as a patent for a multiple telegraph alone; that if not for that it should be construed as a patent for the magneto method, as contrasted distinguished from the voltaic method, or the resistance method; and that if construed more broadly than that, it is void as being a patent for a principle or an art; and further we claim that the two instruments, give the patent what construction you will, those used by the defendant and those used by the complainant, or those described in the patent sued upon, are so completely different, so varied in their principle and mode of action, that the one cannot be held to be an infringement upon the other.

Closing argument of Mr. LYSANDER HILL, for the People's Telephone Company and the Overland Telephone Company:

When an application is filed in the Patent Office, the practice is to allow that application to be amended, formally or informally, upon the specification remaining in the Patent Office.

Then there is another class of amendments made by filing formal papers in the shape of a letter or document addressed

## Argument of counsel.

to the Commissioner, formally amending the application. When that is received the Examiner places it on file, goes to the specification, and marks around the passage that is amended, red lines, striking it out and noting on it that the amendment marked A, B, or C, or whatever it is, is substituted for that passage.

But when the patent finally issues, that document, with its amendments, is sent to the government printer, and the government printer prints it as finally corrected, and the original is sent from the government printing office back to the Patent Office, and remains on file there, and is a part of what is called the "File wrapper and contents." It is a part of the contents of the file wrapper.

When any party applies to the Commissioner of Patents and asks for a certified copy of that file wrapper and contents, he gets a certified copy, among other things, of the document which was originally filed, with all the marks which were on it, whatever they may be, and however they may have been placed upon it.

The Commissioner is careful to make an exact fac-simile copy; hence, in this case you can gather nothing from the printed patent of March 7, 1876, as to the prior history of the application in the Patent Office.

But if you take the certified copy of April 10, 1879, as printed in the Dowd record, that being a certified copy, you get not only the original document which was filed in the Patent Office, but you find noted on that copy the various changes which were made in it while it was there and before the patent issued.

The document of April 10, 1879, shows you how it had been corrected before the issue of the patent.

The damaging facts with regard to the George-Brown paper have not been explained. My learned friends say that there is no evidence as to when Brown got that copy from Bell; but yet it is proved that Brown got that copy from Bell on January 25 or 26, 1876, in New York.

## Argument of counsel.

What explanation had they to make of the fact that those two papers were together there, that they were both papers relating to the same subject matter, but that there were declarations of the most important character in one which do not appear in the other, declarations in one which are entirely inconsistent with those in the other?

My learned friend, Mr. Dickerson, says Bell understood perfectly that those two currents were equivalents and did not think it necessary to put it into the George-Brown specification; but Bell did not regard them as equivalents, for he had put into that George-Brown copy an explicit statement which excluded the variable resistance current from the invention.

When Brown left New York he must have known that there was not only the current that was shown in his papers, but that there was another current, the variable resistance current, which would do the work equally well; and yet, as a capitalist, he was going to Europe to patent the invention and to secure the monopoly of it.

Can you conceive of a capitalist taking an invention abroad, spending his money upon it, and trying to get a monopoly of it, under such circumstances, leaving the door wide open, losing his monopoly, throwing it away?

The George-Brown copy of the specification stated only four advantages for multiple telegraph purposes of this current.

If this variable resistance matter has not been interpolated into the American patent since George Brown left for Europe, there was another advantage of that current stated in that document which would strike George Brown as of very great importance. This discovery included a means of preventing the lagging of cable signals. This was a practical improvement which would address itself to him as of great importance. Now, that advantage was not contained in Brown's specification which he took to Europe. When did it come in, and how? That was one of the three interpolated matters. It came in with the variable resistance inter-



## Argument of counsel.

polation, and is of itself a strong proof of the interpolated character of the whole thing.

Before these interpolations were made, Bell had nothing in his mind except the magneto currents caused by the induction of an armature.

Bell never dreamed of using them for ocean cables; but when his associates or his attorney learned of this new current of Gray's, this current by which you can vary the resistance of a battery current, then you had something which you could use on ocean telegraphs, whereas the former current, a description of which Brown had taken to Europe in his document, could not be utilized.

The interpolated description in the specification describes two or three different ways of varying the current.

So far as Bell had any idea of varying the resistance in May, 1875, that idea was limited to one form of apparatus—to vibrate a stretched rod or wire, varying the current.

That idea was tried, failed, and was abandoned. Nothing further appears until you read it here in this patent which issued on March 7. Where did it come from?

On February 14, 1876, Gray had filed his caveat describing the wire dipping in liquid and varying the current by that means by placing the poles nearer together or moving them farther apart in a liquid. That was Gray's thought in the caveat. All of the things described in Bell's patent are on the same principle.

Although there are three different ways of doing it, the only thought, the only principle involved in those three different ways of doing it, is simply using the liquid, an idea which has never before appeared in Bell's history.

It is very curious that without an experiment or thought or word in any letter or memorandum of his, there should suddenly appear in this document—after Brown had left for Europe with his paper containing not a word of it,—three ways, all of which should involve the use of a liquid to vary the resistance.

## Argument of counsel.

Nobody has any right to inspect any model in the Patent Office until after the patent is issued.

Every document, every model, every drawing connected with an application is kept inviolably secret. These gentlemen had no right to inspect Gray's models until after the patent had issued. Hence, if they saw his models, if Mr. Storrow admits that they went to the Patent Office and inspected his models, he admits all that we charge. They had no right to do it. That of itself was a violation of the law.

But this letter shows that Bell not only knew that he had gone as far as any particular model would show or any particular exhibition would show, but he was able to mark out the limits to which Gray had gone. How could he know that?

These parties, who had no right under the rules of the Patent Office to know that Gray even had an application there at all, did have that information.

There is another fact that they have not been able to explain away. There is no explanation of the fact that Bell went home from his visit to Washington on February 25 or 26 to March 3, 1876, and immediately proceeded to construct a liquid transmitter like Gray's, got speech through it on March 10, and then kept still about it, and concealed the fact. There is no explanation that the next step that he took—the next thing that he did—was to construct two magneto devices just like Gray's receiver on or about the first of April, and then got speech through them.

He did not give to the world the fact as to when and where and how he first got articulate speech, but he gave them a lie instead of the fact.

They offer explanation here. They tell you that the liquid transmitter which Bell made was not the same as the Gray liquid transmitter, and therefore it could not have been stolen from Gray.

Mr. Dickerson says, in his argument, that those two instruments, which he has shown on that diagram there, are entirely different in principle; that Gray had the idea of

## Argument of counsel.

varying the resistance of the liquid, but he says that was not Bell's idea.

I prefer to take Bell's theory instead of Gray's. It does not make any difference what liquid is used. His principle is to vary the distance through which the current has to flow through that liquid from pole to pole. Where did Bell get that principle? He had only to read Gray's caveat and find the whole thing there.

I do not think that this Court can afford to allow my friends to do away with the printed evidence in the case, which the complainants have put on file, by coming here and saying it is all a mistake.

My theory is that this paper was put into the Dowd case just as it is printed here in the document; that the print was a correct print from that paper; that subsequently they substituted the fraudulent copy in the Patent Office in order to clear up the record there, and conceal the thing.

Your Honors will remember how Mr. Storrow said this was altered. It was altered by laying it alongside of the George-Brown copy and simply writing into the Patent Office copy—the certified copy from the Patent Office—the words that he found in the George-Brown copy, so far as there was any difference between the two. There is an inherent improbability in that.

How did that word "and" get into that copy that you have before you?

Mr. Storrow says that he put in all those words by comparing it with George Brown's copy. It did not come from the George-Brown copy; it is not there. That explanation does not account for it.

My learned brothers have argued, on the other side, that in law oral evidence has never been allowed to overthrow a patent. It is hardly necessary for me to treat that question. If it was I would refer to *Gayler v. Wilder*, 10 How. 477 [5 Am. & Eng. 188]; *Coffin v. Ogden*, 18 Wall. 120 [9 Am. & Eng. 125].

## Argument of counsel.

The instrument marked "I" in the Drawbaugh Exhibits, they tell us, had no magnet on it when found. It is true that when the original model was put in evidence the magnet was not with it, but after it had been produced before the Examiner, and put in evidence, Mr. Drawbaugh found, among his various magnets at the shop, a magnet which he recognized as the original used in that. He brought that magnet over and placed it on the instrument, and it fitted its place exactly, both in its height, in the size of the poles, which fitted holes made for it, and in every respect it showed for itself at once that it was the magnet originally in the instrument. Mr. Drawbaugh testified to the fact that that was undoubtedly the magnet.

My learned friends say that the tumbler F could not be adjusted unless the bottom was out of it originally, and yet it is the fact that the tumbler instrument F can be adjusted. The bottom was in there; it was adjusted by the screw rod at the top and not at the bottom.

Then my learned friends say the string telephone was in Drawbaugh's shop. That is clearly disproved. There is not a word of evidence of anything of the kind.

A test of those instruments was called for by my friends on the other side, and we made the test in New York. We had no time to make other instruments; we had to take the old instruments that we had, which had got in a very dilapidated condition.

All those instruments operated perfectly well. They were the original instruments of Drawbaugh.

The only instruments that did not operate perfectly satisfactorily were the reproduced instruments that we had made to exhibit the arrangement of the parts; but they did operate as speaking-telephones, even those that were most dilapidated.

The tumbler operated. Mr. Benjamin testifies: Here are some sentences, which I read from the notes, which I

## Argument of counsel.

heard distinctly through F and A. "F" is the tumbler; "A" is the round box. That is the New York test.

We have been criticised for not making further tests in the New York case. Why, we made the tests at the very last end of our testimony.

Professor Barker was very particular to absolutely verify the instruments with which he made those experiments. Now, my learned friends of the other side, admit that we got most excellent results here at the Philadelphia test.

The whole argument is based on the fact that they will not work properly at all when held horizontally, and that the tests in New York failed for that cause, and they succeeded in Philadelphia because held at an angle. I say that it is not true; and if the Court is not satisfied with the evidence of Professor Barker, which I have read, we are ready to repeat the tests here, or have Professor Barker repeat them to the satisfaction of the Court, and in any way the Court may order, to show that those tumbler instruments F will work whether placed horizontally or placed at an angle, and that they will work, if anything, better when placed as they were placed in New York, than as they were placed in Philadelphia.

Then they have complained that we did not have the carbon of the same fineness that we had in New York.

The Hunnings patent says we must pulverize the material finely. What has wheat flour got to do with it? That is not carbon pulverized. Carbon is like sand.

You will find that Drawbaugh, away back in 1881, had stated how to use those carbons, with what degree of fineness.

Before the New York tests, before the Hunnings patent was ever heard of, Professor Barker got better articulation from the fine than from the coarser.

The Philadelphia instruments were constructed in a much more thorough and workmanlike manner than the New York instruments, and were much better finished.

## Opinion of the Court.

The powders used in the Philadelphia test were of hard carbon, of different degrees of fineness.

They would have to be of granular or gritty character, if they were carbon.

The New York instruments had become of such a condition that the parts intended to be rigid would not stay rigid, and the parts intended to be movable would not move easily. But in Philadelphia the parts intended to be rigid were rigid, and then you could take the instrument up in your hand and use it without difficulty, and it would not get out of adjustment. That explains these two tests and all the differences there were between them.

Then, that Blake transmitter is compared with instrument H,—another story which is absolutely incorrect. All the newspaper publications show that they were speaking telephones at Drawbaugh's shop.

Our thirteen witnesses that have been attacked were not the witnesses whose testimony we rely upon most; the attacks are easily answered. They are only thirteen witnesses out of two hundred and twenty. Brother Dickerson admitted to the Court that Drawbaugh made those instruments that these witnesses say he made, and that it is a mere question of the date when he made them. He says their theory is that he commenced to make them in 1876. Our theory is that he commenced to make them a good many years before.

Mr. Chief Justice WAITE delivered the opinion of the Court:

The important question which meets us at the outset in each of these cases is as to the scope of the 5th claim of the patent of March 7, 1876, which is as follows;

“The method of, and apparatus for, transmitting vocal or other sounds telegraphically, as herein described, by causing electrical undulations, similar in form to the vibrations of the air accompanying the said vocal or other sounds, substantially as set forth.”

126 U. S. 531.

## Opinion of the Court.

It is contended that this embraces the art of transferring to or impressing upon a current of electricity the vibrations of air produced by the human voice in articulate speech, in a way that the speech will be carried to and received by a listener at a distance on the line of the current. Articulate speech is not mentioned by name in the patent. The invention, as described, "consists in the employment of a vibratory or undulatory current of electricity, in contradistinction to a merely intermittent or pulsatory current, and of a method of, and apparatus for, producing electrical undulations upon the line-wire." A "pulsatory current" is described as one "caused by sudden or instantaneous changes of intensity," and an "electrical undulation" as the result of "gradual changes of intensity exactly analogous to the changes in the density of air occasioned by simple pendulous vibrations."

Among the uses to which this art may be put is said to be the "telegraphic transmission of noises or sounds of any kind," and it is also said that the undulatory current, when created in the way pointed out, will produce through the receiver at the receiving end of the line "a similar sound to that uttered into" the transmitter at the transmitting end. One of the means of imparting the necessary vibrations through the transmitter, to produce the undulations, may be the human voice. Articulate speech is certainly included in this description, for it is an "uttered" "sound" produced by the "human voice."

It is contended, however, that "vocal sounds" and "articulate speech" are not convertible terms, either in acoustics or in telegraphy. It is unnecessary to determine whether this is so or not. Articulate speech necessarily implies a sound produced by the human voice, and, as the patent on its face is for the art of changing the intensity of a continuous current of electricity by the undulations of the air caused by sonorous vibrations, and speech can only be communicated by such vibrations, the transmission of speech in

## Opinion of the Court.

this way must be included in the art. The question is not whether "vocal sounds" and "articulate speech" are used synonymously as scientific terms, but whether the sound of articulate speech is one of the "vocal or other sounds" referred to in this claim of the patent. We have no hesitation in saying that it is, and that if the patent can be sustained to the full extent of what is now contended for, it gives to Bell and those who claim under him, the exclusive use of his art for that purpose, until the expiration of the statutory term of his patented rights.

In this art—or, what is the same thing under the patent law, this process, this way of transmitting speech—electricity, one of the forces of nature, is employed; but electricity, left to itself, will not do what is wanted. The art consists in so controlling the force as to make it accomplish the purpose. It had long been believed that if the vibrations of air caused by the voice in speaking could be reproduced at a distance by means of electricity, the speech itself would be reproduced and understood. How to do it was the question.

Bell discovered that it could be done by gradually changing the intensity of a continuous electric current, so as to make it correspond exactly to the changes in the density of the air caused by the sound of the voice. This was his art. He then devised a way in which these changes of intensity could be made and speech actually transmitted. Thus his art was put in a condition for practical use.

In doing this, both discovery and invention, in the popular sense of those terms, were involved; discovery in finding the art, and invention in devising the means of making it useful. For such discoveries and such inventions the law has given the discoverer and inventor the right to a patent—as discoverer, for the useful art, process, method of doing a thing he has found; and as inventor, for the means he has devised to make his discovery one of actual value. Other inventors may compete with him for the ways of giving



## Opinion of the Court.

effect to the discovery, but the new art he has found will belong to him and those claiming under him during the life of his patent. If another discovers a different art or method of doing the same thing, reduces it to practical use, and gets a patent for his discovery, the new discovery will be the property of the new discoverer, and thereafter the two will be permitted to operate each in his own way without interference by the other. The only question between them will be whether the second discovery is in fact different from the first.

The patent for the art does not necessarily involve a patent for the particular means employed for using it. Indeed, the mention of any means, in the specification or descriptive portion of the patent, is only necessary to show that the art can be used; for it is only useful arts—arts which may be used to advantage—that can be made the subject of a patent. The language of the statute is that “any person who has invented or discovered any new and useful art, machine, manufacture, or composition of matter,” may obtain a patent therefor. Rev. Stat. § 4886. Thus, an art—a process—which is useful is as much the subject of a patent, as a machine, manufacture, or composition of matter. Of this there can be no doubt, and it is abundantly supported by authority. *Corning v. Burden*, 15 How. 252 [6 Am. & Eng. 69]; *Cochrane v. Deener*, 94 U. S. 780 [11 Am. & Eng. 288]; *Tilghman v. Proctor*, 102 U. S. 708 [13 Am. & Eng. 29]; *New Process Fermentation Co. v. Maus*, 122 U. S. 413 [17 Am. & Eng. 157].

What Bell claims is the art of creating changes of intensity in a continuous current of electricity, exactly corresponding to the changes of density in the air caused by the vibrations which accompany vocal or other sounds, and of using that electrical condition thus created for sending and receiving articulate speech telegraphically. For that, among other things, his patent of 1876 was in our opinion issued; and the point to be decided is, whether as such a patent it can be sustained.

## Opinion of the Court.

In *O'Reilly v. Morse*, 15 How. 62 [5 Am. & Eng. 483], it was decided that a claim in broad terms (p. 86) for the use of the motive power of the electric or galvanic current called "electro-magnetism, however developed, for making or printing intelligible characters, letters or signs, at any distances," although "a new application of that power" first made by Morse, was void, because (p. 120) it was a claim "for a patent for an effect produced by the use of electro-magnetism, distinct from the process or machinery necessary to produce it;" but a claim (p. 85) for "making use of the motive power of magnetism, when developed by the action of such current or currents, substantially as set forth in the foregoing description, \* \* \* as means of operating or giving motion to machinery, which may be used to imprint signals upon paper or other suitable material, or to produce sound in any desired manner, for the purpose of telegraphic communication at any distances," was sustained. The effect of that decision was, therefore, that the use of magnetism as a motive power, without regard to the particular process with which it was connected in the patent, could not be claimed, but that its use in that connection could.

In the present case the claim is not for the use of a current of electricity in its natural state as it comes from the battery, but for putting a continuous current in a closed circuit into a certain specified condition suited to the transmission of vocal and other sounds, and using it in that condition for that purpose. So far as at present known, without this peculiar change in its condition it will not serve as a medium for the transmission of speech, but with the change it will. Bell was the first to discover this fact, and how to put such a current in such a condition, and what he claims is its use in that condition for that purpose, just as Morse claimed his current in his condition for his purpose. We see nothing in Morse's case to defeat Bell's claim; on the contrary, it is in all respects sustained by that authority. It may be that electricity cannot be used at all for the transmission of speech

126 U. S. 534-535.

## Opinion of the Court.

except in the way Bell has discovered, and that, therefore, practically, his patent gives him its exclusive use for that purpose, but that does not make his claim one for the use of electricity distinct from the particular process with which it is connected in his patent. It will, if true, show more clearly the great importance of his discovery, but it will not invalidate his patent.

But it is insisted that the claim cannot be sustained, because when the patent was issued Bell had not in fact completed his discovery. While it is conceded that he was acting on the right principle and had adopted the true theory, it is claimed that the discovery lacked that practical development which was necessary to make it patentable. In the language of counsel "there was still work to be done, and work calling for the exercise of the utmost ingenuity, and calling for the very highest degree of practical invention."

It is quite true that when Bell applied for his patent he had never actually transmitted telegraphically spoken words, so that they could be distinctly heard and understood at the receiving end of his line, but in his specification he did describe accurately and with admirable clearness his process, that is to say, the exact electrical condition that must be created to accomplish his purpose; and he also described, with sufficient precision to enable one of ordinary skill in such matters to make it, a form of apparatus which, if used in the way pointed out, would produce the required effect, receive the words, and carry them to and deliver them at the appointed place. The particular instrument which he had and which he used in his experiments did not, under the circumstances in which it was tried, reproduce the words spoken, so that they could be clearly understood, but the proof is abundant and of the most convincing character, that other instruments, carefully constructed and made exactly in accordance with the specification, without any additions whatever, have operated and will operate successfully.

## Opinion of the Court.

A good mechanic of proper skill in matters of the kind can take the patent and, by following the specification strictly, can, without more, construct an apparatus which, when used in the way pointed out, will do all that it is claimed the method or process will do. Some witnesses have testified that they were unable to do it. This shows that they, with the particular apparatus they had and the skill they employed in its use, were not successful; not that others, with another apparatus, perhaps more carefully constructed or more skilfully applied, would necessarily fail. As was said in *Webster Loom Co. v. Higgins*, 105 U. S. 580 [14 Am. & Eng. 70], "when the question is, whether a thing can be done or not, it is always easy to find persons ready to show how not to do it." If one succeeds, that is enough, no matter how many others fail. The opposite results will show, that in the one case the apparatus used was properly made, carefully adjusted, with a knowledge of what was required, and skilfully used, and that in the others it was not.

The law does not require that a discoverer or inventor, in order to get a patent for a process, must have succeeded in bringing his art to the highest degree of perfection. It is enough if he describes his method with sufficient clearness and precision to enable those skilled in the matter to understand what the process is, and if he points out some practicable way of putting it into operation. This Bell did. He described clearly and distinctly his process of transmitting speech telegraphically by creating changes in the intensity of a continuous current or flow of electricity in a closed circuit, exactly analogous to the changes of density in air occasioned by the undulatory motion given to it by the human voice in speaking. He then pointed out two ways in which this might be done; one by the "vibration or motion of bodies capable of inductive action, or by the vibration of the conducting wire itself in the neighborhood of such bodies;" and the other "by alternately increasing and diminishing the resistance of the circuit, or by alternately increasing and

126 U. S. 536.

## Opinion of the Court.

diminishing the power of the battery." He then said he preferred to employ for his purpose "an electro-magnet, \* \* \* having a coil upon only one of its legs," and he described the construction of the particular apparatus shown in the patent as Fig. 7, in which the electro-magnet, or magneto method, was employed. This was the apparatus which he himself used without entirely satisfactory results, but which Prof. Cross, Mr. Watson, Dr. Blake, Prof. Pope, and others testify has done, and will do, what was claimed for it, and transmit speech successfully, but not so well indeed as another constructed upon the principle of the microphone or the variable resistance method.

An effort was made in argument to confine the patent to the magneto instrument, and such modes of creating electrical undulations as could be produced by that form of apparatus, the position being that such an apparatus necessarily implied "a closed circuit incapable of being opened, and a continuous current incapable of being intermittent." But this argument ignores the fact that the claim is, first, for the process, and, second, for the apparatus. It is to be read, 1, as a claim for "the method of transmitting vocal or other sounds telegraphically, as herein described, by causing electrical undulations similar in form to the vibrations of the air accompanying the said vocal or other sounds, substantially as set forth;" and, 2, as for "the apparatus for transmitting vocal or other sounds telegraphically, as herein described, by causing electrical undulations, \* \* \* substantially as set forth." The method, "as herein described," is to cause gradual changes in the intensity of the electric current used as the medium of transmission, which shall be exactly analogous to the changes in the density of the air, occasioned by the peculiarities in the shapes of the undulations produced in speech, in the manner "substantially as set forth;" that is to say, "by the vibration or motion of bodies capable of inductive action, or by the vibration of the conducting wire itself in the neighborhood of such bodies,"

## Opinion of the Court.

which is the magneto method; or "by alternately increasing and diminishing the resistance of the circuit, or by alternately increasing and diminishing the power of the battery," which is the variable resistance method. This is the process which has been patented, and it may be operated in either of the ways set forth. The current must be kept closed to be used successfully, but this does not necessarily imply that it must be so produced, or so operated upon, as to be incapable of being opened. If opened, it will fail to act for the time being, and the process will be interrupted; but there is nothing in the patent which requires it to be operated by instruments which are incapable of making the break.

The apparatus, "as herein described," which is included in the claim, is undoubtedly one in which an electro-magnet is employed, and constructed "substantially as set forth" in the specification. One acting on the variable resistance mode is not described, further than to say that the vibration of the conducting wire in mercury or other liquid included in the circuit occasions undulations in the current, and no other special directions are given as to the manner in which it must be constructed. The patent is both for the magneto and variable resistance *methods*, and for the particular magneto *apparatus* which is described, or its equivalent. There is no patent for any variable resistance apparatus. It is undoubtedly true that when Bell got his patent he thought the magneto method was the best. Indeed, he said, in express terms, he preferred it, but that does not exclude the use of the other if it turns out to be the most desirable way of using the process under any circumstances. Both forms of apparatus operate on a closed circuit by gradual changes of intensity, and not by alternately making and breaking the circuit, or by sudden and instantaneous changes, and they each require to be so adjusted as to prevent interruptions. If they break it is a fault, and the process stops until the connection is restored.

It is again said, that the claim, if given this broad con-

## Opinion of the Court.

struction, is virtually "a claim for speech transmission by transmitting it; or, in other words, for all such doing of a thing as is provable by doing it." It is true that Bell transmits speech by transmitting it, and that long before he did so it was believed by scientists that it could be done by means of electricity, if the requisite electrical effect could be produced. Precisely how that subtle force operates under Bell's treatment, or what form it takes, no one can tell. All we know is, that he found out that, by changing the intensity of a continuous current so as to make it correspond exactly with the changes in the density of air caused by sonorous vibrations, vocal and other sounds could be transmitted and heard at a distance. This was the thing to be done, and Bell discovered the way of doing it. He uses electricity as a medium for that purpose, just as air is used within speaking distance. In effect he prolongs the air vibrations by the use of electricity. No one before him had found out how to use electricity with the same effect. To use it with success it must be put in a certain condition. What that condition was he was the first to discover; and with his discovery he astonished the scientific world. Prof. Henry, one of the most eminent scientists of the present century, spoke of it as "the greatest marvel hitherto achieved by the telegraph." The thing done by Bell was "transmitting audible speech through long telegraphic lines," and Sir William Thomson, on returning to his home in England, in August or September, 1876, after seeing at the Centennial Exposition, in Philadelphia, what Bell had done, and could do, by his process, spoke in this way of it to his countrymen: "Who can but admire the hardihood of invention which devised such very slight means to realize the mathematical conception that, if electricity is to convey all the delicacies of quality which distinguish articulate speech, the strength of its current must vary continuously, as nearly as may be, in simple proportion to the velocity of a particle of air engaged in constituting the sounds." Surely a patent for

## Opinion of the Court.

such a discovery is not to be confined to the mere means he improvised to prove the reality of his conception.

We come now to consider the alleged anticipation of Philip Reis. And here it is to be always kept in mind that the question is, not whether the apparatus devised by Reis to give effect to his theory can be made, with our present knowledge, to transmit speech, but whether Reis had in his time found out the way of using it successfully for that purpose; not as to the character of the apparatus, but as to the mode of treating the current of electricity on which the apparatus is to act, so as to make that current a medium for receiving the vibrations of air created by the human voice in articulate speech at one place, and in effect delivering them at the ear of a listener in another place. Bell's patent is not alone for the particular apparatus he describes, but for the process that apparatus was designed to bring into use. His patent would be quite as good if he had actually used Reis's apparatus in developing the process for which it was granted.

That Reis knew what had to be done in order to transmit speech by electricity is very apparent, for in his first paper he said: "As soon as it is possible to produce, anywhere and in any manner, vibrations whose curves shall be the same as those of any given tone or combination of tones, we shall receive the same impression as that tone or combination of tones would have produced on us." Bourseul also knew it before Reis, for, in a communication published in a Paris journal in 1854, he said: "Reproduce precisely these vibrations," to wit, the vibrations made by the human voice in uttering syllables, "and you will reproduce precisely these syllables."

Reis discovered how to reproduce musical tones; but he did no more. He could sing through his apparatus, but he could not talk. From the beginning to the end he has conceded this. In his first paper he said: "Hitherto it has not been possible to reproduce the tones of human speech with



## Opinion of the Court.

a distinctness sufficient for every one. The consonants are for the most part reproduced pretty distinctly, but the vowels as yet not in an equal degree. The cause of this I will attempt to explain. According to the experiments of Willis, Helmholtz, and others, vowel tones can be produced artificially, if the vibrations of one body are from time to time augmented by those of another, something as follows: An elastic spring is set in vibration by the blow of a tooth on a toothed wheel; the first vibration is the greatest, and each subsequent one is smaller than the preceding. If, after a few vibrations of this kind (the spring not coming to a rest in the meantime), the toothed wheel imparts a new stroke, the following vibration will be again a maximum, and so on. The pitch of the tone produced in this way depends upon the number of vibrations in a given time, but the character of the tone upon the number of swellings in the same time. \* \* \* Our organs of speech probably produce the vowels in the same manner, through the combined action of the upper and lower vocal chords, or of these latter and the cavity of the mouth. My apparatus reproduces the number of vibrations, but with an intensity much less than that of the original ones; though, as I have reason to believe, to a certain degree proportional among themselves. But in the case of these generally small variations, the difference between large and small vibrations is more difficult to perceive than in the case of the original waves, and the vowel is therefore more or less indistinct." And again: "I have succeeded in constructing an apparatus with which I am enabled to reproduce the tones of various instruments, and even to a certain extent the human voice."

No one of the many writers whose papers are found in the records claim more than this for Reis or his discoveries. Although his first paper was published in 1861, and Bell did not appear as a worker in the same field of scientific research until nearly fifteen years afterwards, no advance had been made, by the use of what he had contrived or of his method,

## Opinion of the Court.

toward the great end to be accomplished. He caused his instruments to be put on the market for sale, and both he and those whom he employed for that purpose took occasion to call attention to them by prospectus, catalogue, and otherwise, and to describe what they were and what they would do. In his own prospectus, which was published in 1865 and attached to the apparatus, he says: "Every apparatus consists \* \* \* of two parts, the telephone proper and the receiver. \* \* \* These two parts are placed at such a distance from each other that singing or toning of a musical instrument can be heard in no other way from one station to the other except through the apparatus." And, "besides the human voice there can be reproduced (according to my experience) just as well the tones of good organ-pipes from F—c, and those of the piano." Albert, the mechanic employed to make the instruments, in his catalogue published in 1866, enumerates among the things he has for sale "Telephone of Reis for reproduction of tones by electricity." In a work on electricity by Robert M. Ferguson, published by William and Robert Chambers, London and Edinburgh, in 1867, it is said, in speaking of the telephone: "This is an instrument for telegraphing notes of the same pitch. Any noise producing a single vibration of the air, when repeated regularly a certain number of times in the second (not less than thirty-two), produces, as is well-known, a musical sound. \* \* \* A person when singing any note causes the air to vibrate so many times per second, the number varying with the pitch of the note he sings, the higher the note the greater being the number of vibrations. If we then by any means can get these vibrations to break a closed circuit, \* \* \* the note sung at one station can be reproduced, at least so far as pitch is concerned, at another. Reis's telephone (invented 1861) accomplishes this in the following way," which is then described.

But it is needless to quote further from the evidence on this branch of the case. It is not contended that Reis had

126 U. S. 541-542.

## Opinion of the Court.

ever succeeded in actually transmitting speech, but only that his instrument was capable of it if he had known how. He did not know how, and all his experiments in that direction were failures. With the help of Bell's later discoveries in 1875 we now know why he failed.

As early as 1854 Bourseul, in his communication which has already been referred to, had said, substantially, that if the vibrations of air produced by the human voice in articulate speech could be reproduced by means of electricity at a distance, the speech itself would be reproduced and heard there. As a means of stimulating inquiry to that end he called attention to the principle on which the electric telegraph was based, and suggested an application of that principle to such a purpose. He said: "The electric telegraph is based on the following principle: An electric current, passing through a metallic wire, circulates through a coil around a piece of soft iron, which it converts into a magnet. The moment the current stops, the piece of iron ceases to be a magnet. This magnet, which takes the name of electromagnet, can thus in turn attract and then release a movable plate, which, by its to and fro movement, produces the conventional signals employed in telegraphy." Then, after referring to the mode in which speech is transmitted by the vibrations of the air, he said: "Suppose that a man speaks near a movable disk, sufficiently flexible to lose none of the vibrations of the voice; that this disk alternately makes and breaks the connection with a battery; you may have at a distance another disk which will simultaneously execute the same vibrations."

That Reis was working all the time, from the beginning to the end of his experiments, upon the principle of the telegraph as thus suggested by Bourseul, is abundantly proven. Thus, in his first paper, after describing his cubical block apparatus, he says: "If now tones or combinations of tones are produced in the neighborhood of the block, so that sufficiently powerful waves enter the opening *a*, then these sounds

## Opinion of the Court.

cause the membrane *b* to vibrate. At the first condensation the hammer-like wire *d* is pushed back; at the rarefaction it cannot follow the retreating membrane, and the current traversing the strips remains broken, until the membrane forced by a new condensation again presses the strip \* \* \* against *d*. In this way each sound-wave causes a breaking and closing of the current. At each closing of the circuit the atoms of the iron wire inside the distant spiral are moved away from each other; on breaking the circuit these atoms seek to regain their position of equilibrium. When this happens, in consequence of the reciprocal actions of elasticity and inertia, a number of vibrations are produced, and they give the longitudinal sound of the rod. This is the case if the making and breaking of the current occur with comparative slowness. If they occur more rapidly than the oscillations of the iron core, due to its elasticity, the atoms cannot complete their course. The paths described become shorter in proportion as the interruptions are more frequent, but then are just as numerous as these. The iron wire no longer gives its longitudinal normal tone, but a tone whose pitch corresponds to the number of interruptions in a given time; this is the same as saying that the rod reproduces the tone impressed upon the interrupter."

Such was the beginning, and it was maintained persistently to the end, as well by Reis as by those who availed themselves of what he was doing. To this the Reis-Legat apparatus forms no exception, for in the paper describing it Legat says: "The operation of the apparatus described is as follows: When at rest the galvanic circuit is closed. When the air which is in tube *a b* of the apparatus is alternately condensed and rarefied by speaking into it (or by singing or introducing the tones of an instrument), a movement of the membrane closing the smaller opening of the tube is produced, corresponding to such condensation or rarefaction. The lever *c d* follows the movements of the membrane, and opens and closes the galvanic circuit at *d g*,  
126 U. S. 543-544.

## Opinion of the Court.

so that at each condensation of the air in the tube the circuit is opened, and at each rarefaction the circuit is closed. In consequence of this operation the electro-magnet of the apparatus, in accordance with the condensations and rarefactions of the column of air in the tube \* \* \* is correspondingly demagnetized and magnetized, and the armature of the magnet is set into vibrations like those of the membrane in the transmitting apparatus." We have not had our attention called to a single item of evidence which tends in any way to show that Reis, or any one who wrote about him, had it in his mind that anything else than the intermittent current caused by the opening and closing of the circuit could be used to do what was wanted. No one seems to have thought that there could be another way. All recognized the fact that the "minor differences in the original vibrations" had not been satisfactorily reproduced, but they attributed it to the imperfect mechanism of the apparatus used, rather than to any fault in the principle on which the operation was made to depend.

It was left for Bell to discover that the failure was due not to workmanship, but to the principle which was adopted as the basis of what had to be done. He found that what he called the intermittent current—one caused by alternately opening and closing the circuit—could not be made under any circumstances to reproduce the delicate forms of the air vibrations caused by the human voice in articulate speech, but that the true way was to operate on an unbroken current by increasing and diminishing its intensity. This he called a vibratory or undulatory current, not because the current was supposed to actually take that form, but because it expressed with sufficient accuracy his idea of a current which was subjected to gradual changes of intensity exactly analogous to the changes of density in the air occasioned by its vibrations. Such was his discovery, and it was new. Reis never thought of it, and he failed to transmit speech telegraphically. Bell did, and he succeeded. Under such cir-

## Opinion of the Court.

cumstances it is impossible to hold that what Reis did was an anticipation of the discovery of Bell. To follow Reis is to fail, but to follow Bell is to succeed. The difference between the two is just the difference between failure and success. If Reis had kept on he might have found out the way to succeed, but he stopped and failed. Bell took up his work and carried it on to a successful result.

As to what is shown to have been written and done by Dr. Van der Weyde, it is only necessary to say that he copied Reis, and it was not until after Bell's success that he found out how to use a Reis instrument so as to make it transmit speech. Bell taught him what to do to accomplish that purpose.

So as to James W. McDonough. We presume that it will not be claimed that he is entitled to more than he asked for in his application for a patent, filed April 10, 1876, and there a "circuit-breaker," so adjusted as to "break the connection by the vibrations of the membrane," is made one of the elements of his invention. The Patent Office was clearly right in holding that he had been anticipated by Reis.

The patents of Cromwell Fleetwood Varley, of London, England, granted on June 2, 1868, and the other, October 8, 1870, were for "improvements in electric telegraphs." The objects of the invention covered by the first were "to cut off the disturbance arising from earth currents, to obtain a high speed of signaling through long circuits, and, should the conductor become partially exposed, to preserve it from being eaten away by electrolytic action," and the object of the second was the "increase of the transmitting power of telegraph circuits, by enabling more than one operator to signal independent messages at the same time, upon one and the same wire, to and from independent stations." While this patentee in his specification says, "by my invention I superpose upon the currents used for working the ordinary telegraphs, rapid undulations or waves, which do not practically alter the mechanical or chemical power of the ordinary

126 U. S. 545-546.

## Opinion of the Court

signal currents," and that "these undulations are made to produce distinct and independent audible or other signals so long as these undulations are produced, whether ordinary signal currents be flowing or not," it is apparent that he uses the terms "undulations" and "waves" in an entirely different sense from Bell, for his patent implies operation on the principle of the electric telegraph; that is to say, by making and breaking the circuit. A Morse key, or something equivalent, is to be used; and besides, in the descriptive portion of the patent, it is said: "When the current is flowing through the coils of the electro-magnet the horns of the fork *k* are drawn apart and the spring *l* loses its contact; then, as the attraction of the magnet ceases, the horns of the fork spring back; this remakes the contact, and so a continual tremor is communicated to the tuning fork." In short, there is nothing in any part of the specification to indicate that the patentee had in his mind "undulations" resulting "from gradual changes of intensity exactly analogous to the changes in the density of air occasioned by simple pendulous vibrations," which was Bell's discovery, and on which his art rests. Varley's purpose was to superpose, that is to say, place upon the ordinary signal current another, which, by the action of the make and break principle of the telegraph, would do the work he wanted.

Another alleged anticipation is that of Daniel Drawbaugh.

Bell got his patent March 7, 1876, and the fortunate accident which led to his discovery occurred June 2, 1875. Active litigation to enforce his patented rights was begun by his company on the 12th of September, 1878, with a suit in the Circuit Court of the United States for the District of Massachusetts, against Richard A. Dowd. This suit was defended by the Western Union Telegraph Company, and vigorously contested. The answer was filed November 4, 1878, setting up alleged anticipations by Gray, Edison, Dolbear, and others. The record fills twelve hundred printed pages, but before a decision was reached the case was com-

## Opinion of the Court.

promised and a decree entered by consent. The litigation ended at some time in the latter part of the year 1879. The last deposition was taken on the 19th of September in that year.

The next contested suit was brought in the same Court on the 28th of July, 1880, against Albert Spencer and others. An answer was filed in this case September 6, 1880, and depositions afterwards taken, some of those in the Dowd suit being used in this by stipulation. On the 27th of June, 1881, a decision was announced by Judge LOWELL, sustaining the patent, upon which a decree was entered.

On the 14th of November, 1879, Abner G. Tisdell filed in the Patent Office an application for a patent for "a new and useful improvement in speaking-telephones," and on the 18th of November, 1879, Frank A. Klemm also filed an application for a patent for "a new and useful improvement in telephone-transmitters." These inventions were transferred by assignment to Ernest Marx and Frank A. Klemm, of New York City; Moritz Loth, of Cincinnati, and Simon Wolf, of Washington. On the 6th of March, 1880, these parties entered into a mutual agreement to the effect that "each and all of their interests in said improvements and inventions, and the letters patent to be issued therefor, shall be merged and consolidated as common stock in a corporate body, under the laws of either of the States of Ohio, New York, or the general laws of the United States, relating to the formation of incorporations in the District of Columbia, or of such other States or Territories as may be found necessary hereafter." This agreement was recorded in the Patent Office March 10, 1880.

On the 6th of May, 1880, Edgar W. Chellis, a merchant of Harrisburg, Pennsylvania, M. W. Jacobs, a lawyer of the same place, and Lysander Hill, a lawyer then residing in Washington, in the District of Columbia, made an arrangement with Daniel Drawbaugh by which they were to become jointly interested with him in his alleged telephone



## Opinion of the Court.

inventions, each to have a quarter interest. Nothing was paid for this, but each of the parties was to have one-fourth of anything that should be realized from the enterprise. On the 24th of May, 1880, Simon Wolf, one of the parties interested in the Klemm and Tisdell inventions, visited Harrisburg on business with Chellis in reference to telephone matters. On the 18th of May, four days before this visit, a patent was issued to Wolf and his associates upon the invention of Tisdell. While Wolf was in Harrisburg negotiations were begun with Chellis for a transfer of the Drawbaugh inventions to the owners of those of Klemm and Tisdell. These negotiations resulted in a conditional contract of the 22d of June, by reason of which Chellis, Jacobs, Hill, and Drawbaugh went to Washington, and there, on the 21st of July, 1880, Drawbaugh, claiming to "have invented certain new and useful improvements in the transmission of vocal speech, and the apparatus to be used for such purpose, for which I am about to make application for letters patent of the United States," assigned to Klemm, Marx, Wolf, and Loth "the full and exclusive right to the said invention as fully set forth and described in the specification prepared and executed by me, dated the 21st day of July, 1880, preparatory to obtaining letters patent of the United States therefor," and he, at the same time, and by the same instrument, authorized and requested the Commissioner of Patents to issue the patent to his assignees, "each as assignee of one-fourth part. The specification referred to in the assignment has not been put in evidence in any of the cases. In the course of taking the testimony it was called for by the Bell Company, but the counsel for the opposite party refused to produce either the original or a copy from the Patent Office. The assignment was recorded in the Patent Office, July 22, 1880, and in the official digest of assignments the following notation appears: "About to make appl'n. Spe'n dated July 21, 1880."

On the morning of July 22, 1880, the following appeared

## Opinion of the Court.

in the *Cincinnati Commercial*, a newspaper printed at Cincinnati, Ohio:

## "TELEPHONE COMBINATION.

"*Special to Cincinnati Commercial.*

"WASHINGTON, D. C., July 21.—An application for a patent was filed to-day that, in consequence of its vastness of interest, as well as wealth of prospect, renders it a subject of national interest. A company of leading business men has been formed, that has bought up all the telephone patents antedating those now in use, and known as the Bell, Gray, and Edison patents. The company is composed of leading business men from all parts of the country, Cincinnati being largely represented and interested. The cash capital of the company is \$5,000,000, with headquarters in New York, and in about sixty days they will open up the telephone, which will certainly result in the driving out of all telephones in the market, save the ones they hold, or else compelling the Gray, Bell, and Edison lines to pay the new company a munificent royalty. It appears from the testimony now on file and in the possession of the new company, which is conclusive and exhaustive, that the inventor of the telephone is a poor mechanic, living near Harrisburg, Pa., named Daniel Drawbaugh. Owing to his poverty, he was unable to push his patent on the market. The new company have secured and are sole possessors of this invention, antedating those now in use. They are also owners of four patents for telephones issued to Mr. Klemm, of New York. A large number of capitalists were here to-day to see the filing of the application, and they assert, with a positiveness that is almost convincing, that it will not be long till they have entire charge of the telephones, not only in this country but in the world, and that they will be able to establish lines by which messages can be transmitted for almost a song.

"Mr. Lipman Levy, of the law firm of Moulton, Johnson & Levy, of Cincinnati, was here to-day, in the interest of the  
126 U. S. 548-549.

## Opinion of the Court.

Cincinnati parties, who, as already stated, are among the most prominent financial men of our city."

Afterwards, on the 23d of August, 1880, the following appeared in the *Journal of Commerce*, a newspaper printed in the city of New York:

## "A NEW TELEPHONE COMPANY.

"A company has recently been formed in this city, with a capital of \$5,000,000, for the purpose of manufacturing telephones. The company is to be known as the People's Telephone Company, and a number of leading capitalists in this city and Cincinnati are interested in it. The telephones are to be manufactured under the patents of Frank A. Klemm and Abner G. Tisdell, and the application for patents of Daniel Drawbaugh, of Eberly's Mills, Cumberland county, Pa., filed July 21, 1880. It is claimed, by those interested in the new enterprise, that Drawbaugh is really the inventor of the telephone, and had completed one year before Professor Bell or any one else had manufactured one. He was, however, in very humble circumstances, and his neighbors who knew of his experiments looked upon him as a harmless lunatic. He continued improving his original telephone, and it is claimed that the one which the new company proposes to furnish is superior to any now in use. The company has fitted up a factory in Brooklyn, and in three months will be prepared to supply 1,000 of the new telephones. As soon as operations are actively commenced, it is expected that legal proceedings will be begun against the new company by the Gold and Stock Telegraph Company, which holds most of the existing patents, and a long and interesting legal fight is anticipated."

On the 30th of August, 1880, the People's Telephone Company was incorporated under the general laws of New York, with an authorized capital stock of \$5,000,000, for "manufacturing, constructing, owning, furnishing, letting and selling telephones, and the apparatus used therewith,

## Opinion of the Court.

under the inventions and patents of Abner G. Tisdel, Frank A. Klemm, Daniel Drawbaugh, and other inventions and patents which may hereafter be assigned to said company;” and on the 4th of September, 1880, Klemm, Loth, Marx, and Wolf, in consideration of \$4,999,550, represented by 99,991 shares of stock, assigned and transferred to that company all their interest in the Klemm, Tisdel, and Drawbaugh inventions, those of Drawbaugh being described as “the inventions in telephones made by Daniel Drawbaugh, of Eberly’s Mills, Cumberland county, in the State of Pennsylvania, for which application for patents was made on or about the 21st day of July, 1880, and which was assigned to us on the [twenty-] first day of July, 1880, as more particularly appears in a deed of assignment recorded in the United States Patent Office, in Liber W. 25, page 85, in the Book of Transfers of Patents.”

For the assignment from Drawbaugh to Klemm, Marx, Loth, and Wolf \$20,000 was paid in money to Chellis, Jacobs, Hill, and Drawbaugh, and they were also to have a certain amount of the stock of the proposed corporation when formed. What amount they actually got Chellis, who was sworn as a witness in the case, declined to tell, but he admitted it was large.

At this time, and in this way, the attention of the general public was called for the first time to the fact that Drawbaugh claimed to have anticipated Bell in the discovery of the telephone. Bell’s success had been proclaimed more than four years before at the Centennial Exposition in Philadelphia. In the mean time inventions in aid of his discovery had been multiplied. According to the testimony of Park Benjamin, more than one hundred patents had been issued and indexed under the word “telephone.” Numerous interferences had been declared and considered at the Patent Office. Gray, Edison, Dolbear, and others had either claimed for themselves, or others had claimed for them, priority of invention and discovery, and Bell had thus far been sustained

## Opinion of the Court.

as against them all. Blake had perfected his microphone apparatus, and Bell's patent had become a great commercial success.

The People's Company either began, or threatened to begin, operations under its charter, and on the 20th of October, 1880, the Bell Company brought suit against it in the Circuit Court of the United States for the Southern District of New York, to prevent any infringement of the Bell patents. In the bill it was alleged "that telephone exchanges now exist in more than two hundred and seventy-five towns and cities of the United States, and in every State thereof, and exist in substantially every city in the United States having more than 15,000 inhabitants, and in many smaller places;" "that there are now in use more than 100,000 electric speaking-telephones licensed by and paying royalty to" the Bell Company; "that the owners of said Bell patents, and those who now are or heretofore have been licensed by them, have devoted great time and attention and large sums of money to the development of the telephone and the introduction thereof into extensive use, and to the proper construction of the most suitable telephone lines and systems and telephonic appliances, and have constructed many thousand miles of telephone lines for use with telephones owned by" the Bell Company, "and licensed by it for such use, and that nothing which the defendants, or F. A. Klemm, A. G. Tisdel, and D. Drawbaugh \* \* \* have done has contributed in any substantial way to the development of the telephone or the introduction thereof into use." The bill then avers that Klemm, Marx, Loth, and Wolf, having become the owners of the Klemm and Tisdel improvements, and having heard that Drawbaugh "claimed that he had made some experiments relating to electric speaking-telephones (which experiments, if made, were incomplete, imperfect, unfruitful, and long before abandoned), entered into an arrangement with him to set up and claim that he was the first inventor of the speaking-telephone, and to make application for a patent therefor; and thereafter,

## Opinion of the Court.

alleging and pretending that said Drawbaugh was the original and first inventor of the electric speaking-telephone, and that electric speaking-telephones had not before such application been in public use or on sale for more than two years; with the knowledge and consent of Drawbaugh, they did, on or about the 21st day of July, 1880, induce him to make and cause to be filed in the Patent Office of the United States, an application for a patent to issue to them as assignees of the said Drawbaugh, as the first and original inventor of the electric speaking-telephone, the said defendants well knowing at the time that electric speaking-telephones had been in public use by "the Bell Company and its licensees "for more than two years before said application." It was then further alleged that if Drawbaugh had ever made his pretended inventions they "have not been by him, or any one claiming under him, introduced into public use, and that knowledge thereof has been withheld from your orators and the public, except so far as they have been disclosed within the three months last past by certain newspaper publications."

To this bill the People's Company filed an answer in December, 1880, or January, 1881. The record does not show the precise date. In this answer it was said that Drawbaugh was "the original and first inventor and discoverer of the art of communicating articulate speech between distant places by voltaic and magneto electricity," and that "long prior to the alleged inventions by" Bell, Gray, and Edison he, "then and now residing at Eberly's Mills, constructed and operated practical working electric speaking-telephones at said Eberly's Mills, and exhibited their successful operation to a great number of other persons resident in his vicinity and elsewhere;" that his telephones, as then constructed and operated, "contained all the material and substantial parts and inventions patented" in the patents of Bell, and "also other important and valuable inventions in electric and magneto telephony, and were fully capable of

## Opinion of the Court.

transmitting, and were actually used for transmitting, articulate vocal sounds and speech between distant points by means of electric currents; that some of the original machines and instruments, invented, made, used and exhibited to many others long prior to the said alleged inventions of Bell, or either of them, are still in existence, and capable of successful practical use, and are identified by a large number of persons who personally tested and used them, and knew of their practical operation and use, in the years 1870, 1871, 1872, 1873, 1874, and both prior and subsequently thereto; that certainly more than fifty, and probably not less than one hundred persons, or even more, were cognizant of said Drawbaugh's invention, and use of said telephones, and of his claim to be the original and first inventor thereof prior to the alleged inventions of said Bell, or either of them; that said Drawbaugh, for more than ten years prior to the year 1880, was miserably poor, in debt, with a large and helpless family dependent on his daily labor, and was, from such cause alone, utterly unable to patent his invention, or caveat it, or manufacture and introduce it on the market; that said Drawbaugh never abandoned his said invention, nor acknowledged the claims of any other person or persons thereto, but always persisted in his claims to it, and intended to patent it as soon as he could procure the necessary means therefor; that said Drawbaugh never acquiesced in the public use of said Bell, Gray, Edison, Blake, or other telephones, nor in the claims of the alleged inventors thereof, nor gave his consent to such use." It is then said that Drawbaugh, after finding by experiment that his invention was capable of successful working, "conceived that its range and capacity for usefulness to the public might be very greatly enlarged; that many improvements of great value might be made and added to it, which, without departing from its principle, might increase its value to himself and to the public, and therefore set himself at work to discover and invent such improvements; that he discovered and invented some of said addi-

## Opinion of the Court.

tional improvements prior to any alleged invention by Bell; and that notwithstanding his embarrassed and impoverished pecuniary condition, and his utter want of proper mechanical tools, materials, and appliances to conduct such work, he labored with all reasonable diligence to perfect and adapt his said improvements, and did finally, in due exercise of such reasonable diligence, perfect and adapt the same; and that in so far as said Bell has incorporated such improvements in his said two patents, or either of them, he, the said Bell, has surreptitiously and unjustly obtained a patent or patents for that which was in fact first invented by Drawbaugh, who was using reasonable diligence in perfecting and adapting the same, and therefore, the patent or patents of the said Bell therefor is or are invalid and void." It is then said that "the defendant in good faith, and relying upon its legal rights \* \* \* caused applications to be made and filed in the Patent Office for letters patent on the inventions of the said Daniel Drawbaugh, with the intention of procuring interference proceedings to be instituted, in accordance with the statute, against the patents of said Bell, and the pending applications of said Gray, Edison, and others, in order that said Drawbaugh may be adjudged by the Commissioner of Patents to be, as he rightfully is, the original and first inventor of the electric speaking-telephone, and may be adjudged entitled to receive a patent or patents therefor."

The People's Company began taking depositions on the 19th of April, 1881, but Drawbaugh himself did not appear as a witness until December 7, 1881. After that time others were examined, and when the proofs were closed between three and four hundred witnesses had been produced, whose testimony was taken and put into the record to establish the priority of Drawbaugh's invention. The testimony, as is now claimed, shows the story of that invention to have been as follows:

126 U. S. 554-555.



## Opinion of the Court.

“Early conception and experiments with the continuous current, 1862, 1866, and 1867.

“Tea-cup transmitter and receiver, 1866 and 1867.

“Tumbler and tin-cup and mustard can (‘F’ and ‘B’), 1867 and 1869.

“Improvement on ‘B,’ (‘C’), 1869, 1870.

“Further improvement upon ‘C,’ and the more perfect magneto instrument ‘I,’ 1870, 1871.

“Mouthpiece changed to centre and adjusting screw inserted, (Exhibit ‘A’), 1874.

“‘D’ and ‘E,’ perfectly adjusted and finished magneto instruments, January and February, 1875.

“‘L,’ ‘M,’ ‘G,’ and ‘O,’ from February, 1875, to August, 1876.

“‘H,’ August, 1876.

“‘J,’ ‘N,’ and ‘P,’ 1878.”

This statement of the Drawbaugh claim we have quoted from the brief of counsel appearing in his behalf, and his success in the litigation has been placed, as we understand it, both in the answer and in the argument, on the truth or falsehood of what is thus set forth.

The letters “F,” “B,” etc., in the statement refer to exhibits in the cause, being certain instruments claimed to have been made and used by Drawbaugh in the progress of his work and preserved until now. The original tea-cup instrument was not produced, but Drawbaugh in his deposition gave what he said was a drawing, showing how it had been constructed. “F,” “B,” “C,” “I,” and “A,” were neither of them in a condition for use when they were put in evidence, and no one of all the witnesses, except Drawbaugh, could tell how they were originally constructed, or what the process was by which sound was transmitted when they were used. All any of the witnesses could say on the subject was, that they had used one or more of the different instruments at Drawbaugh’s shop, had heard sounds and sometimes spoken words through them, and that Drawbaugh

## Opinion of the Court.

told them the sound was carried on the wire by electricity. There was nothing whatever produced in print or in writing on the subject; not even a memorandum or a drawing of any kind. And there is nothing in the testimony to show that Drawbaugh ever told any one how his earlier instruments were made, or what his process was, until he was called as a witness in December, 1881, and explained it in his testimony. This was nearly twenty years, according to the present claim, after he had begun his experiments, nearly seven after he had made and used "D" and "E," "perfectly adjusted and finished magneto instruments," and more than five after "L," "M," "G," "O," and "H," had been constructed and kept in his shop. It was also nearly six years after the date of Bell's patent, more than five years after the success of his discovery had been proclaimed at the Centennial Exposition in Philadelphia, four after his process had got into public use, three after it had become an established success, and two after he had brought his first suit for the establishment of his rights against Dowd, who represented the Western Union Telegraph Company, to a successful termination.

Under these circumstances it becomes important to consider the conduct of Drawbaugh in reference to his alleged invention during this twenty years of eventful history as connected with the discovery and use of telephones. If his present claim is true, his experiments began almost as far back as those of Reis, and he had in his shop at Eberly's Mills, within three miles of Harrisburg, telephones that were substantially perfect months before Bell, on the 2d of June, 1875, got the clue to his subsequent discoveries. It is conceded that "D" and "E" made, as is claimed, in February, 1875, are substantially as good magneto instruments as any Bell had used before December, 1881, and "L," "M," "G," "O," and "H," all of which it is claimed were constructed by August, 1876, and some in February, 1875, are as good or nearly as good microphones as those of Blake,  
126 U. S. 556-557.

## Opinion of the Court.

which were not invented till 1878. This is the theory of Drawbaugh's defence as it is set forth in the answer and in the argument, and by it his case must stand or fall. The claim is that the discovery of the process was complete, and that perfect telephones had been made and were in a condition for use a year and more before Bell got his patent.

Drawbaugh was, when he gave his deposition, fifty-four years of age, and had lived all his life at or near Eberly's Mills, a small village near Harrisburg. He was a skilful and ingenious mechanic, and if he made "D" and "E," and the instruments which came after them, at the time it is said he did, he had good tools and good materials in 1875 and 1876, and was capable of doing the best of work. He was also somewhat of an inventor, and had some knowledge of electricity. According to the testimony, he was an enthusiast on the subject of his "talking machine," and showed it freely to his neighbors and people from the country when they visited his shop.

The Centennial Exposition was opened at Philadelphia in May, 1876, and Drawbaugh visited it on the 17th of October, 1876, remaining four or five days. Before he went he had heard, as he says, that some one besides himself had invented a speaking telephone, which he had the impression was on exhibition there. If what he now claims is true, he had then on hand in his shop exhibits "D," "E," "L," "M," "G," "O," and "H," all of them good instruments of their kind, and capable of transmitting speech, and some of them but just finished. Bell's apparatus had been exhibited to the Board of Judges in June before, and had attracted marked attention. The matter was much discussed in the public press, and yet it never seems to have occurred to Drawbaugh to take any of his telephones with him when he went, although they were small in size, and some, or all of them, could have been carried without serious inconvenience.

When giving his testimony he was examined in chief as

## Opinion of the Court.

to that visit, and this is what he said on the subject of telephones:

“Q. 386. Did you attend the Centennial Exhibition, at Philadelphia, in the year 1876? A. Yes, sir; I did.

“Q. 387. Can you give the date on which you went there? A. I can by reference to a book. It was October 17, 1876. The 17th was a day on which I dated a letter from Philadelphia, while I was there on that visit.

“Q. 388. How long did your visit there last? A. About four or five days, to the best of my recollection.

“Q. 389. Who went with you on that visit? A. Mr. George Leonard.

“Q. 390. Was that the only visit to the Centennial Exhibition that you made? A. Yes, sir; it was.

“Q. 391. At the time that you went there, or before that time, had you heard that somebody else besides yourself had invented a speaking telephone—or a telephone? A. Yes, sir; some time before that, I don't remember how long, but not a great while.

“Q. 392. When you went there, did you suppose it would be on exhibition there? A. I don't remember whether I had heard that it was on exhibition or not; but I got the impression some way that it was on exhibition.

“Q. 393. While you were there at the Centennial, did you see any telephones, or make an effort to see any there? A. Yes, sir; I made an effort, and seen an instrument called a telephone, and supposed it to be the instrument spoken of—the one of which I had heard. I was looking and had made some inquiry, and was directed or came to a portion of the building where I saw on a counter some man's telephone, the name I don't remember. At that time, or several times that I called, there was no one there to attend to it. I spoke to another party that had something else on exhibition—I don't recollect what it was—just near by, and I asked him whether there was any one there to attend or

126 U. S. 557-558.

## Opinion of the Court.

to show the instruments. I was informed then there was no one there to show them.

“Q. 394. If you remember, please state what kind of an instrument it was that you saw there, and state what information you were able to obtain there regarding it and its mode of operation. A. There was a number of instruments placed on to a raised portion—something like a shelf. That is, it resembled something like pigeon-holes, a box open in front, and each instrument at the back of it had an electromagnet. The number of instruments I don't remember. I don't remember of counting them. If I am not mistaken there may have been a dozen or more, perhaps; some were larger than others. I could not give you a much better description than that. I couldn't get any information about them. This attendant made some remarks about the instruments, but he didn't understand them, and couldn't explain them. I was several feet from where the instruments were. They were placed—it occurs to me—on a raised place like a shelf, just about high enough for a man to speak into; that is the way it looked to me. I did not go in behind the counter to examine them, although there was an opening to go in by, because I did not like to make too free, as there was no one there.

“Q. 395. Did you see any circulars lying around there referring to these instruments, or other advertisements of them? A. I don't remember about that; it may have been.

“Q. 396. What was your impression as to the character of the instruments, when you finally left them? A. I was impressed with the idea that they were instruments to telegraph by sounds. A certain sound to represent a certain letter of the alphabet. I am not certain how I got the idea, or whether any person told me that at the time; but that is the idea that I had. When I said certain sounds, I meant that sounds of a different pitch would represent different letters.

“Q. 397. Do you know whether that was ‘Gray's Har-

## Opinion of the Court.

monic Telegraph' that you saw there or not? A. It didn't say 'telegraph;' I am confident it was called 'telephone.' I didn't see the working parts of the interior, except the electro-magnets. I took the name of the man and his address on a piece of paper, and put it in my pocket, but I don't know what became of it. I don't know whether it was 'Gray's Harmonic Telegraph' or not.

"Q. 398. Did you see any tuning forks about it? A. I did not."

That was all he did during his entire visit to ascertain whether any one besides himself had actually entered upon this then new and interesting field of invention and discovery. He spoke to no one about what he had done himself, and he made no special effort to find out whether that which was on exhibition was in any respect like what he had at home. Neither did he when he got home, so far as the records show, say anything to his neighbors or visiting friends about what he had seen or heard. He had apparently lost all interest in "talking machines."

Not so, however, with his other inventions. The testimony shows that during the early part of 1876, he was much occupied in building an electric clock, which he thought of exhibiting at the Centennial. This he did not do, however, but either just before he went to Philadelphia, or soon after, Rufus E. Shapley, a jeweler of Mechanicsburg, went by his invitation, or on his suggestion, to Eberly's Mills to look at the clock which he had made. Soon afterwards the clock was taken to Shapley's store in Mechanicsburg, and on the 8th of November, 1876, Drawbaugh by an instrument in writing transferred to Shapley a half interest in the "clock I am getting up, the said R. E. Shapley to pay for patenting the same." Shapley had then two thousand dollars in money which Drawbaugh was anxious to have him invest in that business, and the clock was taken by him to his shop, so that it might be examined with that end in view if it should prove to be useful. Some time afterwards it was taken back

## Opinion of the Court.

to Eberly's Mills, where it remained until April 1, 1878, or thereabouts, when a clock company was formed, and that clock, or another one substantially like it, was taken about the country for exhibition. For this Drawbaugh was paid five hundred dollars, with an interest in the profits, and on the 20th of September, 1878, he applied for a patent for "improvement in earth batteries for electric clocks," which was issued January 14, 1879, to the members of the clock company. The enterprise does not seem to have been productive of any great success.

In November or December, 1878, while this clock was on exhibition at Harrisburg, Drawbaugh was introduced to Edgar W. Chellis. He had with him at the time a "wooden model of a faucet" that he wanted Chellis and another man to take each a third interest in. An arrangement was afterwards made by which Chellis got a two-thirds interest, he paying for it two hundred and fifty dollars, January 7, 1879. On the 14th of the same month Drawbaugh filed in the Patent Office an application for a patent for an "improvement in rotary measuring faucets," Chellis to have a two-thirds interest. After this application an interference was declared, March 29, 1879, between Drawbaugh and David A. Hauck, who had filed a conflicting application January 17. In his preliminary statement upon this interference Drawbaugh said that he had conceived the idea of his faucets and sketched them late in the fall of 1876; that he had made a working model in the spring of 1877, and actually tested it then, but the Patent Office model was not completed until about the 1st of November, 1878. The case was closely contested, but finally decided in favor of Drawbaugh, January 15, 1880. The patent was granted to him and Chellis July 6 of the same year. In this contest Jacobs and Hill, who afterwards became interested in his telephone claims, appeared as the counsel of Drawbaugh.

On the 2d of July, 1879, Drawbaugh filed another application in the Patent Office for "improvement in water mo-

## Opinion of the Court.

tors," Chellis to have in this also a two-thirds interest. Upon this application a patent was issued March 16, 1880.

It is impossible to believe, if Drawbaugh had in his shop, when he reached home from the Centennial, Exhibits "D," "E," "L," "M," "G," "O," and "H," or even "D" and "E" alone, that he would have set himself to work, in the first instance, at developing his clock enterprise, or perfecting his former conception of a measuring faucet, instead of making some effort to call the attention of his friends to his great discovery of the telephone, which he was in danger of losing by the patent which had been issued to another, and which he could not but have known was even then attracting the greatest attention. And in this connection it must be kept in mind that the theory of the defence is, as stated in the answer, that Drawbaugh had at that time fully perfected his invention, and that while at first he "conceived that its range and capacity for usefulness to the public might be very greatly enlarged," he had, before the date of Bell's patent, "notwithstanding his embarrassed and impoverished pecuniary condition, and his utter want of proper mechanical tools," finally perfected his work. His conduct, afterwards, therefore, is to be judged, not as that of one who was still in the midst of his experiments, and doubtful of the results, but of one who had arrived at the end and had completed his success.

No man of his intelligence, with or without the enthusiasm upon the subject which it is said he possessed, could have remained silent under such circumstances. As we have read the testimony, it is not even pretended that he took any of his instruments outside of his own village until May, 1878, when, as is claimed, he showed one to his friend Stees, in Harrisburg, whom he had known for years, and who was the first to use, and, in fact, was then using, a Bell telephone, in that place, upon a private line of his own between his office and his shops. This produced no results, and when afterwards, in January, 1879, Chellis was told



## Opinion of the Court.

that Drawbaugh had "a phonograph and a telephone that he had invented," he gave it no attention, because, to use his own language, "I was interested in the faucet and motor business, and wished to push them, and I did not think we could do much with the telephone, as Bell had a patent, and I did not know that he could antedate them." And again, when speaking of a conversation he had with Drawbaugh, he said: "I advised him to drop it—the telephone—as he could not antedate Bell. He said he did not know about that; that he had been working on it a good while. It was his way of expressing himself; when I would say, 'You can't antedate Bell,' he would say, 'I don't know about that; I have been working at it a good while.'" This, it must be remembered, was in 1879, after the telephone had become a success, and after it had been a year or more in use in Harrisburg, where Chellis lived. It is impossible to believe that either Chellis or Drawbaugh was ignorant of the approximate time of Bell's invention, which had been the subject of frequent newspaper comment from the time of its exhibition at the Centennial. The subject was often referred to in the Harrisburg and Mechanicsburg papers, and it is not for a moment to be supposed that all of these various articles escaped their attention. Under such circumstances, if it were true that Drawbaugh had made his "D" and "E," as is now claimed, in February, 1875, he certainly would have said so, and would not have contented himself with so doubting an answer to Chellis's suggestion of his inability to antedate Bell as that which Chellis now says he gave.

Another important fact in this connection is one which is proved by the testimony of Andrew R. Kiefer, who, from 1863, had been division telegraph operator, having charge of the middle division of the Pennsylvania Railroad, and residing in Harrisburg. From 1867 to the winter of 1881-2 he was a member of a partnership firm in that place, which was engaged in "the manufacture of burglar alarms, electric

## Opinion of the Court.

hotel annunciators, and fine electric work for the government—instruments for the Signal Bureau, patent models," &c. He had also, since 1876, kept a place for the sale of electrical supplies. He had known Drawbaugh certainly since 1876, and probably before. Drawbaugh met him on different occasions and talked upon electrical matters. In the course of their acquaintance Drawbaugh showed him an electrical fire-alarm apparatus and the works of his electric clock, but the subject of telephones was never alluded to between them until in the summer of 1881, when this occurred. We quote from Kiefer's deposition:

"In the summer of 1881 I took my wife out for a drive, and went over to see his (Drawbaugh's) works, never having seen them, and having promised to come and see him some time; my wife, not caring about going through the shop, remained in the carriage, and I went through alone with Mr. Drawbaugh. He showed me through the shops and introduced me to Mr. Chellis, and showed me parts of the water motor and some other things of his getting up. On account of my wife's being in the carriage alone I did not stay long. As I stepped into or was just in the carriage, Mr. Drawbaugh said, 'I forgot to show you my telephone.' I did not get out again to go and see it, and I drove away without seeing it, expecting to see it again, but I have never got over to the shop since."

This was after the suit of the Bell Company against the People's Company was begun, and of course after the matter got into the hands of Chellis and his associates. It is no answer to the criticism of Drawbaugh's conduct in this particular to say, as was said in argument, that "one reason why he did not speak or apply to every man with whom he had personal acquaintance, was that he was ridiculed by his neighbors; that his invention was considered a humbug by them, and of no commercial value." Bell's success was proclaimed in the *Harrisburg Patriot* as early as February 26, 1877, and the days of ridicule were then past. If Draw-

126 U. S. 563-564.

## Opinion of the Court.

baugh had at that time is his shop the machines which it is now claimed were all complete as they now are by August, 1876, and most of them before, there cannot be a doubt that he would have taken them to some place where they could be tried, and show that they would do what he had all along claimed for them. All he had to do, at any time after he came back from the Centennial, was to take any pair of his little instruments to his friend Zeigler or his friend Stees at Harrisburg, attach them to a line-wire, and show what he had. They were men who could appreciate his achievement, and help him if it was, as he now says it was, a success. It would certainly have been easier then, within two years of the time the first of them were made, and within a year of the date of Bell's patent, to show that he "antedated" Bell, than it was three years afterwards, when he was brought into the controversy through the instrumentality of his associates, not, as must be evident to all, to get a patent for himself, but to defeat that of Bell. And in this connection it is specially significant that the application which it is claimed was made for a patent on the 21st of July, 1880, and the specification of his invention which was then written out, have been purposely and designedly kept out of the case, although their production was demanded. They were written before this suit was begun, and it is impossible to believe that they would have been withheld, at least upon the call of the opposite party, if they were in all respects consistent with the subsequent developments of the case. The excuse given by counsel at the time, that they were "in the secret archives of the Patent Office," and "if produced and published in this cause would possibly invite the filing of contesting applications, and result in interference and additional litigation, besides unnecessarily prolonging the taking of testimony here and increasing the expenses," we cannot accept as satisfactory, especially as in the answer it was said that one object of filing the application was to procure "interference proceedings to be instituted against

## Opinion of the Court.

the patents of Bell, in order that Drawbaugh may be adjudged by the Commissioner to be, as he rightfully is, the original and first inventor."

We have not overlooked the depositions that have been taken in such large numbers to show that Drawbaugh was successful with "F," "B," "C," "I," and "A," before "D" and "E" were made. They have been studied with care, and if they contained all the testimony in the case it would be more difficult to reach the conclusion that Drawbaugh's claim was not sustained. But in our opinion their effect has been completely overcome by the conduct of Drawbaugh, about which there is no dispute, from the time of his visit to the Centennial until he was put forward by the promoters of the People's Company, nearly four years afterwards, to contest the claims of Bell. He was silent so far as the general public were concerned, when if he had really done what these witnesses now think he did he would most certainly have spoken. There is hardly a single act of his connected with his present claim, from the time he heard, before going to Philadelphia, that some one else had invented a telephone which was on exhibition at the Centennial, that is not entirely inconsistent with the idea even then of a complete discovery or invention by himself which could be put to any practical use. It is not pretended that what he did was done in private. He had influential friends with ample pecuniary resources, ready to help him in bringing out his inventions when they promised success. He easily got aid for his clock and for his faucet. The news of Bell's invention spread rapidly and at once, and it took but a few months to demonstrate to the world that he had achieved a brilliant success. If it were known at Eberly's Mills alone that Drawbaugh had been doing the same thing for years in his shop there—and it certainly would have been known all through the little village if it had actually been done—no one can believe that the public would be kept in ignorance of it until four years afterwards, when a "special" from Washington "to

126 U. S. 565-566.

## Opinion of the Court.

the *Cincinnati Commercial*” announced a “Telephone Combination” to have entire charge of the telephones, not only in this country, but in the world, that could transmit messages “for almost a song.”

But there is another fact in this case equally striking. As has already been seen, “F,” “B,” “C,” and “I,” were in no condition for use when they were produced and put in evidence. They were mere “remains,” and no one but Drawbaugh himself could tell how they were made or how they were to be used. He undertook to reproduce some of them, especially “F” and “B.” This was in the latter part of 1881, while the testimony was being taken. The Bell Company proposed that they should be tried to see if they would do what the witnesses said had been done with the originals, which the “remains” show must have been exceedingly primitive in their character. The testimony also shows that when they were originally used by or in the presence of the witnesses, no particular care was taken in their adjustment. They were lying around in the shop or standing upon shelves. Some say that when experiments were made they were held in the hand or allowed to stand on the table. Many testify to satisfactory results, and Drawbaugh himself said in his deposition: “I would have persons in the cellar reading printed matter—some advertisement or something—and I could hear the words that were read; and at other times I would go down into the cellar and read something, and coming up they would repeat the words to me that I had read.”

The proposition of the Bell Company was accepted, and the reproductions were tried in March, 1882, under the most favorable circumstances. Three days were occupied in the test, and it is substantially conceded that it was a failure. Occasionally a sound was heard and sometimes a word, but “it would not transmit sentences.” At the time of these experiments “F,” which was the transmitter, was placed on a table, and used as Drawbaugh said it was originally. Two

## Opinion of the Court.

years afterwards other reproductions were presented, differently constructed and used in a different way, and these would "talk," but they were neither made nor used in the same way as the originals. To our minds the result of the second experiments conclusively showed that the original instruments could not have done what the witnesses supposed they did, and that what they saw and heard was produced by some other means than an electric speaking-telephone. We do not doubt that Drawbaugh may have conceived the idea that speech could be transmitted to a distance by means of electricity, and that he was experimenting upon that subject; but to hold that he had discovered the art of doing it before Bell did, would be to construe testimony without regard to "the ordinary laws that govern human conduct." *Atlantic Works v. Brady*, 107 U. S. 192, 203 [14 Am. & Eng. 380]. Without pursuing the subject further we decide that the Drawbaugh defence has not been made out.

Another objection to Bell's patent, put forth in the oral argument of Mr. Hill, and in the printed brief signed by him and in that signed by Mr. Dixon, is that his application as originally filed in the Patent Office did not contain his present 4th claim, or any description of the variable resistance method, and that all which now appears in the specification on that subject, including the 4th claim, was surreptitiously interpolated afterwards.

Bell's application was filed February 14, 1876, and afterwards, during the same day, Elisha Gray filed a caveat, in which he claimed as his invention "the art of transmitting vocal sounds or conversations telegraphically through an electric circuit," and in his specification described the variable resistance method. The precise charge now made in the printed brief of Mr. Hill is, that "Mr. Bell's attorneys had an underground railroad in operation between their office and Examiner Wilbur's room in the Patent Office, by which they were enabled to have unlawful and guilty knowledge of Gray's papers as soon as they were filed in the Patent Office,"

126 U. S. 567.

## Opinion of the Court.

and "that an important invention, and a claim therefor, were bodily interpolated into Bell's specification, between February 14, 1876, and February 19, 1876, by Pollok, in consequence of the guilty knowledge which the latter already had of the contents of Gray's caveat before the declaration of interference with Gray on February 19.

So grave a charge, made in so formal a manner, is entitled to careful consideration. It involves the professional integrity and moral character of eminent attorneys, and requires us to find from the evidence that after Bell swore to his application on the 20th of January, 1876, and after the application thus sworn to had been formally filed in the Patent Office, an Examiner, who got knowledge of the Gray caveat put in afterwards, disclosed its contents to Bell's attorneys; that they were then allowed to withdraw the application, change it so as to include Gray's variable resistance method over Bell's signature, and over the *jurat*, and then restore it to the files, thus materially altered, as if it were the original; and all this between February 14 and February 19.

Although much stress was laid in argument on the fact that what purported to be a certified copy of the specification of Bell, as found in the file wrapper and contents printed in the Dowd case, differed materially from the patent, the cause of these differences has been explained in the most satisfactory manner, and we entertain no doubt whatever that the specification as now found in the patent is precisely the same as that on which the order to issue was made. If any alterations were made it was all done before February 19, and the fair copy which is now found on the files of the office is precisely as it was when the order for the patent was granted. Not a shadow of suspicion can rest on any one growing out of the misprint of the specification in the Dowd case.

All that remains, therefore, on which to rest this serious charge is, that in a paper handed by Bell to George Brown, of Toronto, describing his invention, and which was intended

## Opinion of the Court.

to be used in England to secure a British patent, what is now claimed to be an interpolation in the American application is not to be found. It is but right to say that during the whole course of the protracted litigation upon the Bell patent, no argument was ever presented based on this discrepancy until the brief of Mr. Hill was filed in this Court on the 18th of January, 1887, six days before the argument in these appeals was begun. So far as we are advised nothing had ever before occurred in the cases that seemed to make it necessary to prove when the variable resistance method or the 4th claim was put into the American application, or why it was left out of the paper handed to Brown. It seems always to have been assumed until the cases got here, that because it was in the American patent it was rightfully there. Certainly there is nothing in the pleadings in any of the cases to direct attention to the materiality of this fact.

A comparison of the paper handed Brown with the American application shows that they differ in more than thirty different places besides those which relate to the variable resistance method and the 4th claim. The differences are generally in forms of expression, thus indicating that one was written after the other and evidently for the purpose of securing greater accuracy. The paper handed Brown was clearly a rough draft and not a fair copy, for the record shows that it bore on its face the evidence of many erasures and interlineations. Bell says in his testimony that he began writing his specification in September or October, 1875, and wrote and rewrote it a number of times, finally adopting that mode of expression which seemed to him the best to explain his invention and the relation which one portion bore to another. He visited Brown in Canada in September, and again in December, 1875. The arrangement was made between them on the 29th of December, at this last interview, by which Brown was to interest himself in getting out

126 U. S. 568-569.



## Opinion of the Court.

British patents. Other inventions besides the telephone were included in the contract entered into for that purpose.

Bell returned to Boston on the 1st of January, and immediately set himself to work to complete his specification. He had it done so that it was taken to Washington by Mr. Hubbard about the 10th of that month, and delivered to Pollok and Bailey, the attorneys. It was then examined by the attorneys, found correct, and a fair copy made and returned on the 18th to Bell in Boston, for his signature and oath. It was signed and sworn to in Suffolk county, Massachusetts, January 20, and immediately returned to the attorneys. Afterwards Pollok met Bell in New York, and it was again gone over with care by the two together. No change whatever was made in it at that time, and Pollok took it back with him to Washington.

On the 25th of January, 1876, Bell met Brown, who was then on the way to England, in New York. It is now assumed that the paper which Brown took to England was handed to him then, and because the variable resistance method and the 4th claim were not in that, it is argued that they could not have been in the American specification at that time. But no one has said when the paper was actually handed to Brown. Bell says he cannot tell, but that it must have been after he made his contract with Brown on the 29th of December. As the American specification was signed and sworn to five days before the interview with Brown on the 25th of January, and the paper of Brown differs from it in so many particulars besides that now in question, it would seem to be clear that the paper was a copy of some former draft which Bell had made—possibly one taken to Canada in December—and not of that which was perfected afterwards. As the specification which had been prepared and sworn to was a fair copy, without erasures or interlineations, the fact that the paper handed Brown was not a fair copy would imply that it was not intended to be an exact transcript of the other. At any rate,

## Opinion of the Court.

the bare fact that the difference exists under such circumstances is not sufficient to brand Bell and his attorneys, and the officers of the Patent Office, with that infamy which the charges made against them imply. We therefore have no hesitation in rejecting the argument. The variable resistance method is introduced only as showing another mode of creating electrical undulations. That Bell had had his mind upon the effect of such a method is conclusively established by a letter which he addressed to Mr. Hubbard on the 4th of May, 1875, and which is found in the Dowd record, introduced into the Overland case by stipulation. Its insertion in his final draft of his specification is another proof of the care with which his work had been done.

In the case of the Clay Commercial Company objection was made to the sufficiency of the proof of the incorporation of the American Bell Telephone Company and of its title to the Bell patents. Upon the first point the proof was (1) a special Act of the General Court of Massachusetts, entitled "An Act to Incorporate the American Bell Telephone Company," which authorized certain persons therein named, and their associates, to organize themselves under the provisions of c. 224 of the Acts of 1870, and the Acts in amendment thereof, for telephone purposes; and (2) a certificate of the Secretary of the Commonwealth in the form required by § 11 of c. 224, that certain persons, among whom were the most of those mentioned in the special Act, were legally organized and established as an existing corporation under the name of the American Bell Telephone Company. This section made such a certificate "conclusive evidence of the existence of a corporation" organized under that chapter. The authority granted by the special Act to the persons named, to organize as a corporation in this way, gave them the authority to select a corporate name, and also made the statutory certificate conclusive evidence of their corporate existence.

The objections to the proof of title are not, in our opinion,  
126 U. S. 570-571.

## Opinion of the Court.

well taken. We do not deem it necessary to add to the length of this opinion by referring particularly to the testimony on that point.

This disposes of all the cases so far as the patent of March 7, 1876, is concerned. It remains only to consider the patent of January 30, 1877, about which but little has been said either in the oral or printed arguments. Apparently it received but little attention by counsel or the Court in either of the cases below. In the Dolbear case it was by consent excluded from the decree, and of course is not presented by that record in this Court. In all the other cases the patent was sustained, and the Clay Commercial Company was adjudged to have infringed the 3d, 5th, 6th, 7th and 8th claims; the Molecular Company the 6th, 7th and 8th, but not the 5th; the People's Company the 5th, 6th and 8th; and the Overland Company the 3d, 5th, 6th, 7th and 8th. From the decree in favor of the Molecular Company as to the 5th claim the Bell Company has appealed.

In the case of the Clay Commercial Company it was alleged in the answer that the substantial and material parts of the things described and claimed were described and claimed in a prior British patent taken out by or for Bell, dated December 9, 1876, and that, inasmuch as the American patent does not bear the same date with the foreign patent, and is not limited to expire therewith, it is void. This point has not been pressed in the argument here, and in our opinion it has been settled by the decision of this Court in *O'Reilly v. Morse*, 15 How. 62 [5 Am. & Eng. 488], and impliedly by that in *Siemens v. Sellers*, 123 U. S. 276 [17 Am. & Eng. 284], at the present term, that the effect of § 4887 of the Revised Statutes is not to render invalid an American patent which does not bear the same date as a foreign patent for the same invention, but only to limit its term.

The patent itself is for the mechanical structure of an electric telephone to be used to produce the electrical action on which the first patent rests. The 3d claim is for the

## Dissenting Opinion.

use in such instruments of a diaphragm, made of a plate of iron or steel, or other material capable of inductive action; the 5th of a permanent magnet constructed as described with a coil upon the end or ends nearest the plate; the 6th of a sounding box as described; the 7th of a speaking or hearing tube as described for conveying the sounds; and the 8th of a permanent magnet and plate combined. The claim is not for these several things in and of themselves, but for an electric telephone in the construction of which these things or any of them are used. Hence, the 5th claim is not anticipated by the Schellen magnet, as was decided in the Molecular case below. The patent is not for the magnet, but for the telephone, of which it forms but part. To that extent the decree in that case was erroneous.

It follows that the decree in each of the cases, so far as it is in favor of the Bell Company and those claiming under it, must be affirmed, and that the decree in the Molecular case, so far as it is against that company on the 5th claim of the patent of January 30, 1877, must be reversed, and a decree directed to that extent in its favor. It is consequently so ordered.

Mr. Justice GRAY was not present at the argument, and took no part in the decision of these cases.

Mr. Justice LAMAR, not being a member of the Court when these cases were argued, took no part in their decision.

Dissenting opinion of Justices FIELD, BRADLEY and HARLAN, delivered by Mr. Justice BRADLEY:

Mr. Justice FIELD, Mr. Justice HARLAN and myself are not able to concur with the other members of the Court, sitting in these cases, in the result which has been reached by them. Without expressing an opinion on other issues, the point on which we dissent relates to the defence made on the alleged invention of Daniel Drawbaugh, and applies to all the cases in which that invention is set up. We think that Drawbaugh anticipated the invention of Mr. Bell, who, at most,

126 U. S. 572-573.

## Dissenting Opinion.

is not claimed to have invented the speaking telephone prior to June 10, 1875. We think that the evidence on this point is so overwhelming, with regard both to the number and character of the witnesses, that it cannot be overcome. As this is a question of fact, depending upon the weight of the evidence, and involves no question of law, it does not require an extended discussion on the part of those who dissent from the opinion of the majority—which is very ably drawn, and presents the case with great clearness and force. On the point mentioned, however, we cannot concur in the views expressed.

The essence of the invention claimed by Mr. Bell is, the transmission of articulate speech to a distance, by means of an electrical current subjected to undulations produced by the air vibrations of the voice. There are two modes (as yet discovered) by which these undulations may be thus produced. In one they are produced by interposing in the circuit a substance whose electrical conductivity may be varied by the concussions or vibrations of the air produced by the voice. This is called the variable resistance process, because the electrical current is subjected to the variable resistance (or conductivity) of the substance thus interposed. By the other mode, the undulations are produced by the inductive effect of an armature (or small, flat piece of iron) attached to the membrane spoken against, and placed near to the poles of an electro-magnet situated in the circuit. In both cases, the undulations impart the vibrations which caused them to another diaphragm at a distance (called the receiver) by means of an electro-magnet in the circuit, placed near to an armature affixed to such diaphragm. These vibrations, thus reproduced, are detected by the ear, and the spoken words are heard.

We are satisfied from a very great preponderance of evidence, that Drawbaugh produced, and exhibited in his shop, as early as 1869, an electrical instrument by which he transmitted speech, so as to be distinctly heard and understood,

## Dissenting Opinion.

by means of a wire and the employment of variable resistance to the electrical current. This variable resistance was produced by causing the electrical current to pass through pulverized charcoal, carbon and other substances, acted upon by the vibrations of the voice in speaking. This was the whole invention so far as the principle of variable resistance is concerned.

We are also satisfied that as early as 1871 he reproduced articulate speech, at a distance, by means of a current of electricity, subjected by electrical induction to undulations corresponding to the vibrations of the voice in speaking—a process substantially the same as that which is claimed in Mr. Bell's patent.

In regard to the instrument in which the principle of variable resistance was used, more than seventy witnesses were examined, who either testified to having seen it and heard it, or established such facts and circumstances in relation to it as to put its existence and date beyond a question. With regard to the instrument in which electrical induction was employed to produce the requisite undulations, some forty or fifty witnesses were produced, many of whom saw it and heard speech through it, and others either saw it, or heard it talked about in such a manner as to fix the time when it was in existence. On the questions of time and result there is such a cloud of witnesses in both cases, that it seems almost impossible not to give credence to them. The evidence of some of them may have been shaken with regard to the time they had in mind; but that of the great majority was not shaken at all, but corroborated by circumstances which rendered the proof irrefragable. Many of them, it is true, were plain country people; but they heard the words through the instrument; and that is a matter about which they could not be mistaken. It did not require science nor learning to understand that. But the witnesses were not confined to this class. A number of them were people of position in society, official, professional, and literary,

126 U. S. 574-575.

## Dissenting Opinion.

—all, however, like the inventor, regarding the matter more as one of curiosity than of public importance.

As it would serve no useful purpose to repeat the testimony of these witnesses, we shall refrain from doing so. We will only add that nearly all the original instruments used by Drawbaugh were produced on the trial, and identified by the witnesses. Some of them were broken and in a dilapidated condition, but sufficiently perfect to be accurately reproduced. Their very form and principle of construction showed that they were intended for speaking-telephones and nothing else. Drawbaugh certainly had the principle, and accomplished the result. Perhaps without the aid of Mr. Bell, the speaking-telephone would not have been brought into public use to this day; but that Drawbaugh produced it, there can hardly be a reasonable doubt.

We do not question Mr. Bell's merits. He appreciated the importance of the invention, and brought it before the public in such a manner as to attract to it the attention of the scientific world. His professional experience and attainments enabled him to see, at a glance, that it was one of the great discoveries of the century. Drawbaugh was a different sort of man. He did not see it in this halo of light. Had he done so, he would have taken measures to interest other persons with him in it, and to have brought it out to public admiration and use. He was only a plain mechanic; somewhat better instructed than most ordinary mechanics; a man of more reading, of better intelligence. But he looked upon what he had made more as a curiosity than as a matter of financial, scientific, or public importance. This explains why he did not take more pains to bring it forward to public notice. Another cause of his delay in bringing his invention to public notice was, that he was ever indulging the hope of producing speech, at the receiving end of the line, loud and distinct enough to be heard across a room, like the voice of a person speaking in an ordinary tone.

It is perfectly natural for the world to take the part of the

## Dissenting Opinion.

man who has already achieved eminence. No patriotic Briton could believe that anybody but Watt could produce an improvement in the steam engine. This principle of human nature may well explain the relative feeling towards Bell and Drawbaugh in reference to the invention of the telephone. It is regarded as incredible that so great a discovery should have been made by the plain mechanic, and not by the eminent scientist and inventor. Yet the proof amounts to demonstration, from the testimony of Mr. Bell himself, and his assistant, Watson, that he never transmitted an intelligible word through an electrical instrument, nor produced any such instrument that would transmit an intelligible word, until after his patent had been issued; whilst, for years before, Drawbaugh had talked through his, so that words and sentences had again and again been distinctly heard. We do not wish to say a word depreciatory of Mr. Bell. He was original, if not first. He preconceived the principle on which the result must be obtained, by that forecast which is acquired from scientific knowledge, as Leverrier did the place of the unknown planet; but in this, as in the actual production of the thing, he was, according to the great preponderance of the evidence, anticipated by a man of far humbler pretensions. A common astronomer, by carefully sweeping the sky, might have been first in discovering the planet Neptune; whilst no one but a Leverrier, or an Adams, could have ascertained its existence and position by calculation. So it was with Bell and Drawbaugh. The latter invented the telephone without appreciating the importance and completeness of his invention. Bell subsequently projected it on the basis of scientific inference, and took out a patent for it. But, as our laws do not award a patent to one who was not the first to make an invention, we think that Bell's patent is void by the anticipation of Drawbaugh.



## PETITION FOR REHEARING.

In the cases of the People's Telephone Company and the Overland Telephone Company, a motion for rehearing was made.

It was submitted May 7, 1888; *denied* May 14, 1888.

The following is a copy of the petition for rehearing:

*To the Honorable Justices of said Court:*

The appellants in the above-entitled cases hereby humbly pray that the Court will rehear and reconsider the matters decided March 19, 1888, so far as the same involve the question of priority of invention of the electric speaking-telephone between Alexander Graham Bell and Daniel Drawbaugh; and that an order or orders be entered reversing the decisions below and dismissing the appellees' bills, with costs to the appellants in said cases respectively.

The grounds of this application are, first, that the Court, in its said decision, as evidenced by its written opinion, filed on said 19th day of March, giving its reasons therefor, inadvertently erred in respect to certain matters of fact and of law, material to and decisive of said question, and therefore of these cases; and, secondly, that in consequence of said errors, the decision of the Court was against the weight of the evidence.

"The opinion of the Court treats three portions of the evidence as controlling, viz.:

(1) The evidence of a great cloud of witnesses as to what Drawbaugh, prior to the fall of 1876, had accomplished in the matter of an electric speaking-telephone.

(2) His conduct from that time to the year 1880, when the appellants became interested in his inventions.

(3) The New York and Philadelphia tests.

## I. PROOFS OF DRAWBAUGH'S PRIORITY.

Mr. Storrow, complainants' counsel, admitted in his oral argument that "forty-nine witnesses testified that they had

## Petition for rehearing.

heard speech in Drawbaugh's shop before the date of the Bell patent." (Oral argument of Storrow, p. 149.)

Seventy witnesses heard talk through the Drawbaugh telephones, or were present when others successfully talked through them, prior to Bell's alleged conception of the telephone, June 2, 1875.

One hundred and forty-nine witnesses actually saw the instruments, and two hundred and twenty testified to having heard of or seen them prior to that time.

Many of the witnesses testified to such circumstances, facts, and records corroborative of their evidence as to make it impossible that they could have erred, and either their testimony is true or they committed wilful perjury. No attempt has been made to impeach them. The dates they positively aver are all prior to June, 1875, the year when Bell claimed to have first conceived the idea of the telephone.

Of this class of witnesses are the following:

William H. Strickler: Never was at Milltown but once. Had made an invention for insulating telegraph wires. Visited Drawbaugh for information and advice concerning that invention. Had not then filed his application for a patent. He and Drawbaugh talked to each other through the telephone at that time, and Drawbaugh explained to him how electricity operated it. Subsequently filed his application and obtained a patent for his invention. Produced the specifications and drawings as filed, and the patent as issued. Date of filing, August 22, 1874; date of patent, April 20, 1875 (Additional Proofs, p. 233).

George W. Bowman: Resides at Mechanicsburg. Drove to Eberly's Mills with his wife to attend a baptism. After the baptism drove to Drawbaugh's shop. This was during the lifetime of his wife's mother, who died in 1871. He then and there heard Drawbaugh talk through the telephone (Additional proofs, p. 173).

Mrs. Bowman, wife of the above, corroborated his testi-

## Petition for rehearing.

mony. Her mother died March 14, 1871. Knows the baptism was before her mother's death, because it was upon her mother's persuasion that they went to attend it (Additional Proofs, p. 177).

Emanuel Gregory: Resided at Milltown from March to October, 1870. Then removed to Massachusetts. Has never been in Pennsylvania since until he testified. At Milltown worked at Drawbaugh's shop for faucet company. The company's books corroborate this. Assisted Drawbaugh in his experiments, and heard him talk through his telephone a number of times. Identifies B and F as the instruments (Additional Proofs, p. 185).

William H. Zearing: Had a pair of steelyards relettered by Daniel Drawbaugh. Entered the date and charge therefor in a book, November 23, 1873, as shown by book produced. Never had any steelyards relettered at any other time. When he went for them Drawbaugh talked to him through a telephone, saying, among other things, "The steelyards are finished." Zearing was the secretary of the school board of his township (Def. Sur. Reb. Testimony, p. 122).

Other witnesses of the same class are: Goodyear (Def. Sur. Reb. Tes. p. 1011); David Stevenson (Def. Add. Proofs, p. 141); his two daughters (Def. Add. Proofs, pp. 166, 169); William H. Martin (Def. Sur. Reb. Tes. p. 827); John Kee-fauver (Def. Sur. Reb. Tes. p. 837). See accompanying brief for many others.

## II. DRAWBAUGH'S CONDUCT.

Of the above proofs the Court says: "If they contained all the testimony in the case it would be more difficult to reach the conclusion that Drawbaugh's claim was not sustained. But in our opinion their effect has been completely overcome by the conduct of Drawbaugh—about which there is no dispute—from the time of his visit to the Centennial until he was brought forward by the promoters of the People's Company, nearly four years afterwards, to contest the claims of Bell."

## Petition for rehearing.

This conduct, concerning which the Court says there is no dispute, relates solely to his incapacity as a business man. It is true that there is no dispute as to his incapacity to use, to the best advantage, the opportunity his invention gave him; but the Court has evidently overlooked much testimony to show the constant efforts he did make to secure capital from 1876 to 1880 to enter upon the contention which would be sure to follow an application for a patent. Among the witnesses on this point are: Moffit (Def. Record, Vol. I, p. 497), Chellis (Same, p. 526), Shettel (Same, p. 214). The accompanying brief cites many other witnesses to Drawbaugh's constant and earnest seeking of assistance to push his telephone inventions.

## III. DRAWBAUGH'S IGNORANCE OF THE DATE OF BELL'S INVENTION.

Drawbaugh swore that he did not know the alleged date of Bell's invention until 1880 (Def. Record, Vol. 2, p. 870). The Court must have overlooked this testimony, for they say that he must have known of the approximate time of Bell's invention, because the subject of the invention itself was often referred to in the Harrisburg and Mechanicsburg papers. He did not know but Bell had been at work on it, as he himself had been, for many years. The date of the patent was no guide to the date of the invention.

## IV. DRAWBAUGH'S VISIT TO THE CENTENNIAL.

The failure of Drawbaugh to ascertain, when visiting the Centennial Exhibition, whether the telephone instruments there exhibited by Bell were similar to his own, seems to have been regarded by the Court as strong evidence against his claim. But the Court, after citing questions and answers from 386 to 398, inclusive, overlook the answer to the very next question, in which Drawbaugh testifies that none of the instruments he saw at Philadelphia were the instruments represented in the cuts of Bell's instruments as given in the record in this case.

## Petition for rehearing.

The testimony of Professor Barker (Add. Proofs, p. 7) says that the Bell instruments were not easily accessible in the building at that time. They seem to have been merely exhibited to invited individuals at times of private tests. A fair inference from Drawbaugh's answers cited in the opinion of the Court, and the one omitted, is that he saw the instruments he supposed to be the subject of comment, and they were not telephones at all, but were harmonic telegraphic instruments, which his answers fairly describe.

## V. DRAWBAUGH'S PURSUIT OF HIS INVENTION.

The Court says that he had apparently lost all interest in talking machines from 1876 to 1880. Such a conclusion could only be reached by overlooking the evidence of many witnesses. Among these are Stees and Johnston, who operated his carbon transmitter J at Harrisburg in May, 1878, months before the Blake transmitter was invented (Add. Proofs, pp. 198 and 209). He was constantly exhibiting his telephones during the whole of those four years to numerous witnesses, as will readily be seen by citations in the accompanying brief; but what is absolutely conclusive on this point is the fact that he made the most effective and finished telephones from 1876 to 1880.

## VI. DRAWBAUGH'S NEGLECT TO APPLY FOR A PATENT.

"The cost of an application for a patent being small, the failure of Drawbaugh to make such application is taken by the Court as evidence that he had no invention." But this view leaves out of consideration the certainty of interference proceedings, the cost of which, he was advised, would be enormous, which advice has since been abundantly justified.

## VII. THE TESTS AT NEW YORK AND PHILADELPHIA.

Successful tests of Drawbaugh's instruments, both original and reproduced, were made in New York in 1882, and in Philadelphia in 1885.

The Court says that: "It is substantially conceded that the test in New York was a failure;" that "occasionally

## Petition for rehearing.

sound was heard, and sometimes a word, but it would not transmit sentences." That this was a very material error is shown by the testimony of Mr. Benjamin, at page 1278 of Def. Vol. 2, and by other witnesses. So far from it being conceded that the test at New York was a failure, it was conceded by complainants' counsel, Mr. Storrow, that it was a success. Concerning the single instrument F, he said: "There were one hundred and thirty-seven phrases uttered into it on the second day; seven of those were understood, and some words of seven more, and that is all. The third day they got better. They uttered one hundred and seventy-five phrases into the transmitter; thirty-five of those were heard." (Oral argument in the Circuit Court, p. 92, filed here.)

The Court was of the opinion that the instruments afterwards reproduced and tested at Philadelphia were "not the same," but "differently constructed;" but the Bell Company's expert, Pope, swore that they differed only in being constructed more carefully, and with better workmanship (Complainants' Reply, p. 176).

In the opinion of the Court in this very case, it is said of Bell's original instrument: "The particular instrument which he had, and which he used in his experiments, did not, under the circumstances in which it was tried, reproduce the words spoken so that they could be clearly understood; but the proof is abundant, and of the most convincing character, that other instruments, carefully constructed and made exactly in accordance with the specifications, without any additions whatever, have operated and will operate successfully."

The Court said the instruments were used in a different way at Philadelphia than at New York; that is to say, that at New York they rested on a table, while at Philadelphia they were held in the hand. But Professor Barker testified that he used them both ways at Philadelphia, and that they worked best when standing on the table as they did at New

## Petition for rehearing.

York. (Barker, Ans. 81 and 84, Def. Add. Proofs, p. 28). This evidence is more fully treated in the accompanying brief.

## VIII. THE CONSTRUCTION OF THE INSTRUMENTS.

The Court said that nobody knew the actual construction of the original machines except Drawbaugh himself. But there is much evidence beside that of Drawbaugh as to their construction, as will be seen by reference to the testimony cited in the accompanying brief, for example, II. K. Drawbaugh could reproduce the machines from memory. (Def., Vol. 1, pp. 566-7, Ans. 129, 130.) Steinberger described one from memory (Def., Vol. 1, pp. 344-6); and so did Schrader (Def. Sur. Reb., pp. 470-1); and see ten others cited in brief.

## FINALLY.

The Court says, in its opinion: "We do not doubt that Drawbaugh may have conceived the idea that speech could be transmitted to a distance by means of electricity, and that he was experimenting upon that subject,"—meaning, as is clear from the context, that he did this before Bell's invention.

*The Drawbaugh story, then, is no afterthought growing out of Bell's discoveries, but is based upon the admitted facts of a prior conception of the possibility of electric speech-transmission and prior experiments actually made to accomplish it. The same witnesses who satisfied the judgment of the Court as to these facts, identify the machines and testify to their successful working, and are neither impeached nor contradicted as to these additional facts. At another point, referring to Drawbaugh, the Court says: "He was a skilled and ingenious mechanic. \* \* \* He was also somewhat of an inventor, and had some knowledge of electricity. According to the testimony he was an enthusiast on the subject of the 'talking-machine,' and showed it freely to his neighbors and people from the country when they visited his shop."*

Taking these admitted facts together, his prior conception

## Petition for rehearing.

of the possibility of electric speech-transmission; his experiments to accomplish it; and, during his experiments his enthusiasm about the talking-machine—how can his *enthusiasm* be accounted for? Is it conceivable that enthusiasm resulted from constant failure? Can it be explained on any other reasonable theory than that his machines were producing the successful results about which the corroborating witnesses so abundantly testify? And why should he exhibit the invention so freely to the surrounding public, if it constantly failed to work when thus exhibited? Did he exhibit it as a failure or as a success? Can his conduct at the time, especially when taken in connection with his contemporary declarations that he had achieved the result, and was going to patent the invention, and wanted financial aid to secure the patents, be reconciled with any other theory than that of success? And is it not clear that the Court has erred as to the evidential force of the facts which it admits to have been established?

On account of the errors above referred to, which will be made more apparent by reference to the accompanying brief, and to the end, therefore, that equity may be done, and that this Court may, upon fuller consideration and with the advantage of oral argument, revise its former opinion (if revision be right and proper), your petitioners pray that the Court may be pleased to take their suggestions under a careful consideration and grant a rehearing upon the points upon which said decision was based, and grant such other relief and order as in equity and good conscience may be proper.

New York, May 1, 1888.

LYSANDER HILL,  
GEORGE F. EDMUNDS,  
DON M. DICKINSON,  
CHARLES P. CROSBY,  
HENRY C. ANDREWS,  
*Of Counsel with Appellants.*



## Notes and citations.

The above-named counsel filed a brief, discussing at length the evidence applicable to the petition.

On May 14, 1888, Mr. Justice MILLER delivered the opinion of the Court:

No Justice who united in the opinion of the Court having asked for a rehearing, the application is *denied*.

**Notes :****2. An art is a process :**

Corning v. Burden, 15 How. 256 [6 Am. & Eng. 69].

Cochrane v. Deener, 94 U. S. 780 [11 Am. & Eng. 288].

Tilghman v. Proctor, 102 U. S. 707 [13 Am. & Eng. 29].

New Process Fermentation Co. v. Maus, 122 U. S. 413  
[17 Am. & Eng. 157].

---

**3. Process—patentability :**

O'Reilly v. Morse, 15 How. 62 [5 Am. & Eng. 483].

Corning v. Burden, 15 How. 256 [6 Am. & Eng. 69].

Mowry v. Whitney, 14 Wall. 434 [8 Am. & Eng. 506].

Mitchell v. Tilghman, 19 Wall. 287 [9 Am. & Eng. 174].

Wood Paper Patent, 23 Wall. 566 [10 Am. & Eng. 199].

Cochrane v. Deener, 94 U. S. 780 [11 Am. & Eng. 396].

Downton v. Yaeger Milling Co., 108 U. S. 466 [14 Am. & Eng. 513].

New Process Fermentation Co. v. Maus, 122 U. S. 413  
[17 Am. & Eng. 157].

Lawther v. Hamilton, 124 U. S. 1 [17 Am. & Eng. 396].

---

**When not .**

Brown v. Piper, 91 U. S. 37 [10 Am. & Eng. 272].

Western Electric Co. v. Ansonia Brass & C. Co., 114 U. S. 447 [16 Am. & Eng. 94].

## Notes and citations.

Miller v. Foree, 116 U. S. 22 [16 Am. & Eng. 193].  
Dreyfus v. Searle, 124 U. S. 60 [17 Am. & Eng. 446].  
Mosler Safe, etc., Co. v. Mosler, Bahmann & Co., 127  
U. S. 354 [p. 560 *post*].  
Brown v. District of Columbia, 130 U. S. 87.

---

- 
4. Act 1790, sec. 1; Act 1793, sec. 1; Act 1800, sec. 1; Act  
1836, sec. 6; Act 1863, sec. 1; Act 1870, sec. 24;  
**R. S., sec. 4886.**
- 

---

5. Patentability of a principle :

Le Roy v. Tatham, 14 How. 156 [5 Am. & Eng. 313].  
O'Reilly v. Morse, 15 How. 62 [5 Am. & Eng. 483].  
Le Roy v. Tatham, 22 How. 132 [7 Am. & Eng. 29].  
Burr v. Duryee, 1 Wall. 531 [7 Am. & Eng. 224].  
Mitchell v. Tilghman, 19 Wall. 287 [9 Am. & Eng. 174].  
Pencil Co. v. Howard, 20 Wall. 498 [9 Am. & Eng. 390].  
Fuller v. Yentzer, 94 U. S. 288 [11 Am. & Eng. 138]:  
Tilghman v. Proctor, 102 U. S. 707 [13 Am. & Eng. 29].

---

---

6. Reduction to practice necessary to patentability :

Seymour v. Osborne, 11 Wall. 516 [8 Am. & Eng. 290].  
And see Miller v. Foree, 116 U. S. 22 [16 Am. & Eng. 193.]

---

- 
9. "Substantially as set forth," effect on construction of claim :  
Winans v. Denmead, 15 How. 330 [6 Am. & Eng. 107].

## Notes and citations.

Seymour v. McCormick, 19 How. 96 [6 Am. & Eng. 282].  
Seymour v. Osborne, 11 Wall. 516 [8 Am. & Eng. 290].  
Klein v. Russell, 19 Wall. 433 [9 Am. & Eng. 244].  
Garratt v. Seibert, Bk. 21, L. ed. 956 [9 Am. & Eng. 161].  
Hailes v. Van Wormer, 20 Wall. 353 [9 Am. & Eng. 340].  
Corn Planter Patent, 23 Wall. 181 [10 Am. & Eng. 1].  
Railway Co. v. National Car Brake Co., 110 U. S. 229  
[15 Am. & Eng. 124].  
Brown v. Davis, 116 U. S. 237 [16 Am. & Eng. 212].  
Matthews v. Iron Clad Mfg. Co., 124 U. S. 347 [17 Am. &  
Eng. 455].  
Weir v. Morden, 125 U. S. 98 [17 Am. & Eng. 530].  
Sargent v. Burgess, 129 U. S. 19.

---

---

## 11. Novelty :

Particular mechanical patent *held*, not anticipated by a  
prior patented device, capable of the same application  
but not made with such intent.

Clough v. Gilbert & Barker Mfg. Co., 106 U. S. 178  
[14 Am. & Eng. 237].

See also Tilghman v. Proctor, 102 U. S. 707 [13 Am. &  
Eng. 29].

---

---

19. Act 1836, sec. 8; Act 1839, sec. 6; Act 1870, sec. 25;  
**R. S., sec. 4887.**

---

---

## Term. Effect of prior foreign patent :

O'Reily v. Morse, 15 How. 62 [5 Am. & Eng. 483].

Smith v. Ely, 15 How. 137 [6 Am. & Eng. 1].

## Notes and citations.

Siemens v. Sellers, 123 U. S. 276 [17 Am. & Eng. 284].  
Bate Refrigerating Co. v. Hammond, 129 U. S. 151.

---

---

**Patents in suit :**

No. 174,465. A. G. Bell. March 7, 1876. Improvements  
in Telegraphy.  
No. 186,787. A. G. Bell. January 30, 1877. Improve-  
ments in Telegraphy.

**OTHER SUITS ON SAME PATENTS:**

American Bell Telephone Co. v. Spencer, 1881. 8 Fed. Rep.  
509; 20 O. G. 299.  
American Bell Telephone Co. v. Dolbear, 1883. 15 Fed. Rep.  
448; 23 O. G. 535.  
American Bell Telephone Co. v. Dolbear, 1883. 17 Fed. Rep.  
604.  
American Bell Telephone Co. v. People's Telephone Co., 1884.  
22 Fed. Rep. 309; 22 Blatch. 531; 29 O. G. 1029.  
American Bell Telephone Co. v. People's Telephone Co., 1885.  
25 Fed. Rep. 725; 34 O. G. 561.  
American Bell Telephone Co. v. Ghegan, 1882. 23 O. G. 537.  
American Bell Telephone Co. v. National Improved Telephone  
Co., 1886. 27 Fed. Rep. 663.  
United States v. American Bell Telephone Co., 1886. 29 Fed.  
Rep. 17; 38 O. G. 1237.  
United States v. American Bell Telephone Co., 1887. 30 Fed.  
Rep. 523.  
American Bell Telephone Co. v. Globe Telephone Co., 1887. 31  
Fed. Rep. 729; 24 Blatch. 522.  
United States v. American Bell Telephone Co., 1887. 32 Fed.  
Rep. 591; 41 O. G. 123.  
American Bell Telephone Co. v. American Cushman Telephone  
Co., 1888. 35 Fed. Rep. 734.

Notes and citations.

American Bell Telephone Co. v. Cushman Telegraph and Service Co., 1888. 36 Fed. Rep. 488.

United States v. American Bell Telephone Co., 1888. 128 U. S. 315; Bk. 32 L. ed. 450.

---

---

---

**Cited :**

IN SUPREME COURT IN :

United States v. American Bell Telephone Co., 1888. 128 U. S. 315; Bk. 32 L. ed. 450.

---

---

---

IN CIRCUIT COURTS IN :

American Bell Telephone Co. v. American Cushman Telephone Co., July, 1888. 35 Fed. Rep. 734.

American Bell Telephone Co. v. Cushman Telegraph and Service Co., October, 1888. 36 Fed. Rep. 488.

American Bell Telephone Co. v. Wallace Electric Telegraph Co., February, 1889. 37 Fed. Rep. 672.

Electrical Accumulator Co. v. Julien Electric Co., March, 1889. 38 Fed. Rep. 117.

Grant v. Walter, May, 1889. 38 Fed. Rep. 594; 47 O. G. 1220.

---

---

---



## Syllabus.

JAMES FORNCROOK, APPELLANT, *v.* AMOS I. ROOT.

127 U. S. 176-181. Oct. Term, 1887.

[Bk. 32, L. ed. 97; 43 O. G. 984.]

Affirming *Ibid*, 21 Fed. Rep. 328.

Argued April 13, 1888. Decided April 23, 1888.

*Particular patent construed. Mechanical equivalent.*

1. Letters patent, No. 243,674, granted to James Forncrook, June 28, 1881, for an improvement in Sectional Honey-Frames, adjudged to be invalid for lack of patentable novelty. The claim: "As a new article of manufacture, a blank for honey frames formed of a single piece of wood, having transverse angular grooves *c*, longitudinal groove *d*, and recesses *b*, all arranged in the manner shown and described," construed to make the longitudinal groove *d* a necessary element in the structure; and *held*, that the employment instead of pieces of wax, was not a mechanical equivalent (p. 540.)

[Citations in the opinion of the court:]

Fay *v.* Cordesman, 109 U. S. 408 [15 Am. & Eng. 1]. p. 546.Yale Lock Manufacturing Co. *v.* Sargent, 117 U. S. 373 [16 Am. & Eng. 264]. p. 546.Dryfoos *v.* Wiese, 124 U. S. 32 p. 546.Gage *v.* Herring, 107 U. S. 640 [14 Am. & Eng. 454]. p. 547.

Appeal from a decree of the Circuit Court of the United States for the Northern District of Ohio, dismissing a suit brought by the appellant for the infringement of letters patent.

Opinion below, 21 Fed. Rep. 328.

The facts are fully stated in the opinion.

Mr. WILLIAM P. WELLS for appellant:

Novelty is not negatived by any printed publication, unless the information contained therein is full enough, and

## Argument of counsel.

precise enough, to enable any person skilled in the art to which it relates to make the thing covered by the patent sought to be anticipated.

*Seymour v. Osborne*, 11 Wall. 516 [8 Am. & Eng. 290]; *Downton v. Yeager Milling Co.* 108 U. S. 466 [14 Am. & Eng. 513].

As to what constitutes invention is a question of fact in every case.

*Poppenhusen v. Falke*, 5 Blatch. 49.

Want of invention cannot be predicated of a device or process which first reached the particular result.

*Webster Loom Co. v. Higgins*, 105 U. S. 591 [14 Am. & Eng. 70].

The question of sufficiency of invention is whether the alleged patentable subject possesses the statute requisites of novelty and utility.

*McCormick v. Seymour*, 2 Blatch. 240, 243; *Atlantic Works v. Brady*, 107 U. S. 192 [14 Am. & Eng. 380]; *Phillips v. Detroit*, 111 U. S. 604 [15 Am. & Eng. 269]; *Smith v. Goodyear Dental Vulcanite Co.* 93 U. S. 495 [11 Am. & Eng. 1].

A suggestion made to a patentee will not render his patent invalid, unless it enables him to construct the thing patented without the exercise of inventive thought on his part.

*Alden v. Dewey*, 1 Story, 336; *Pitts v. Hall*, 2 Blatch. 234; *Agawam Co. v. Jordan*, 7 Wall. 602 [8 Am. & Eng. 24]; *Union Paper Collar Co. v. Van Deusen*, 23 Wall. 562 [10 Am. & Eng. 156].

The grant of letters patent is *prima facie* evidence that the patentee is the first inventor.

*Smith v. Goodyear Dental Vulcanite Co.*, 93 U. S. 486 [11 Am. & Eng. 1]; *Lehnbeuter v. Holthaus*, 105 U. S. 94.

The burden of proof to make good this defence is upon the party setting it up.

*Coffin v. Ogden*, 18 Wall. 120 [9 Am. & Eng. 125]; *Cantrell v. Wallick*, 117 U. S. 695 [16 Am. & Eng. 322].



## Argument of counsel.

In order to defeat appellant's patent, public use, for more than two years before application, of defendant's own invention, by persons named, must be alleged and proved.

*Consolidated Fruit Jar Co. v. Wright*, 94 U. S. 92 [11 Am. & Eng. 46]; *Egbert v. Lippmann*, 104 U. S. 333 [13 Am. & Eng. 273]; *Hall v. Macneale*, 107 U. S. 90 [14 Am. & Eng. 291].

Actual abandonment is the result of intention. Such intention must be proved. It is not shown by a mere sale.

*Pitts v. Hall*, 2 Blatch. 238; *McCormick v. Seymour*, Id. 256; *Russell & E. Mfg. Co. v. Mallory*, 10 Blatch. 141, 151.

No substitution of an equivalent for any element or ingredient of a combination, covered by any claim of a patent can avert a charge of infringement of that claim.

*Gill v. Wells*, 22 Wall. 1 [9 Am. & Eng. 471]; *Imhaeuser v. Buerk*, 101 U. S. 656 [12 Am. & Eng. 443].

Two inventions are substantially alike when they perform substantially the same thing in substantially the same way.

*Union Paper Bag Machine Co. v. Murphy*, 97 U. S. 120 [11 Am. & Eng. 494]; *Cantrell v. Wallick*, *supra*.

By the manufacture and sale of parts of a patented invention, where it is intended that the purchaser shall supply the omitted parts, there is an infringement.

*Richardson v. Noyes*, 2 Ban. & Ard. 398; *Wallace v. Holmes*, 5 Fish. Pat. Cas. 37.

There are two classes of combinations recognized by the patent laws, which are properly the subject of a patent.

*Lee v. Blandy*, 2 Fish. Pat. Cas. 93.

A combination patent is one in which all the elements enter into it so as to qualify every other.

*Hailes v. Van Wormer*, 20 Wall. 368 [9 Am. & Eng. 340]; *Pickering v. McCullough*, 104 U. S. 310 [13 Am. & Eng. 238]; *Reckendorfer v. Faber*, 92 U. S. 357 [10 Am. & Eng. 373]; *Webster Loom Co. v. Higgins*, 105 U. S. 591 [14 Am. & Eng. 70]; *Gage v. Herring*, 107 U. S. 640 [14 Am. & Eng. 454].

Messrs. M. D. LEGGETT and JOSEPH A. OSBORNE, for appellee:

## Opinion of the Court.

None of the features found in appellant's device perform any different functions from what they did in earlier honey frames, and none of them perform any joint function.

It is a mere aggregation of devices, and cannot be considered an invention.

Curt. Pat. § 111 *c*; Walker, Pat. § 32; Hailes *v.* Van Wormer, 20 Wall. 353. [9 Am. & Eng. 340]; Reckendorfer *v.* Faber, 92 U. S. 347 [10 Am. & Eng. 373]; Pickering *v.* McCullough, 104 U. S. 310 [13 Am. & Eng. 238].

The most liberal construction the Court can give the patent is that it is for a combination.

Curt. Pat. § 249; Neilson *v.* Harford, 1 Web. Pat. Cas. 317.

The patentee, by the restricted form of his claim, made the groove a material part of his device, and the Court cannot declare that it is immaterial.

U. S. Rev. Stat. § 4888; Union Water-Meter Co. *v.* Desper, 101 U. S. 332 [12 Am. & Eng. 380]; Gage *v.* Herring, 107 U. S. 640 [14 Am. & Eng. 454].

Mr. Justice BLATCHFORD delivered the opinion of the Court:

This is a suit in equity, brought in the Circuit Court of the United States for the Northern District of Ohio, by James Forncrook against Amos I. Root, for the infringement of letters patent of the United States, No. 243,674, granted to the plaintiff, June 28, 1881, for an "improvement in sectional honey frames," on an application filed May 13, 1879.

The specification, claim, and drawings of the patent are as follows:

"Be it known that I, James Forncrook, of Watertown, in the County of Jefferson and State of Wisconsin, have invented certain new and useful improvements in sectional honey frames, and I do hereby declare the following to be a full, clear, and exact description of the invention, such as will enable others skilled in the art to which it appertains to make and use the same, reference being had to the accompanying drawings, and to letters of reference marked

J. FORNCROOK.  
Sectional Honey Frame.

No. 243,674.

Patented June 28, 1881.

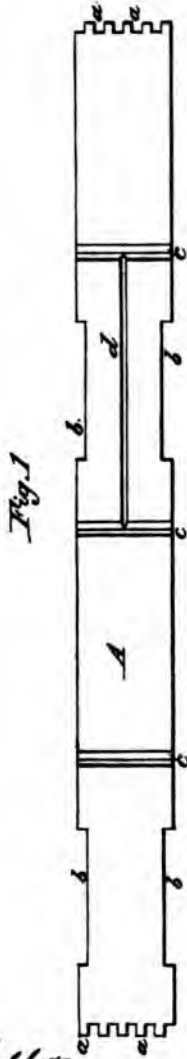

Fig. 1

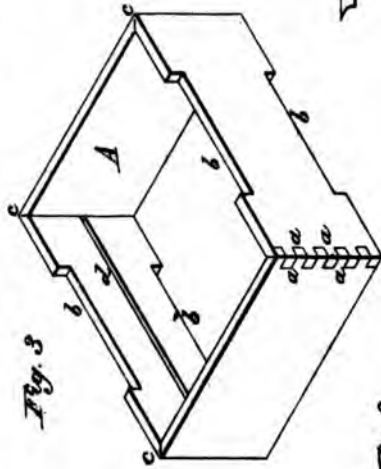

Fig. 3

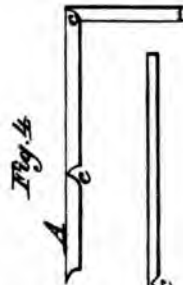

Fig. 4



Fig. 2

Attest:  
F. W. Schott.  
D. P. Cook

Inventor:  
James Forncrook  
Geo. B. Foster & Co.  
attys



## Opinion of the Court.

thereon, which form a part of this specification. This invention relates to an improvement in sectional honey frames, the object being to so construct them that they shall be stronger and in a more portable form than the frames now used for such purposes; and the invention consists essentially in forming the frames from a single blank or piece of material having all the necessary grooves and recesses required to form a complete frame cut in it, the ends of the blank being notched or dentated, and angular grooves cut across it at those points which are to form the corners. These blanks, after being thus prepared, may be packed solidly in boxes, or otherwise, for transportation, and, when required for use, are bent into the square forms, and their ends united at one of the corners, by means of the interlocking notches or teeth, thus forming a complete frame ready for use. In the drawings, Fig. 1, is a plan of one of the blanks, showing the various recesses and grooves with which it is supplied. Fig. 2 is an edge view of the blank, and shows the form and depth of the angular grooves which form the corners of the frame. Fig. 3 shows the blank bent into a square form, with the ends united, making a complete frame ready for use. Fig. 4 shows a modification of the groove, or miter, *c*, Fig. 2. The blanks for these frames are preferably formed from some light, tasteless, and comparatively tough wood, which will bend at the corners without steaming or boiling, such as basswood or whitewood, the material being produced by cutting it from the log in the form of a thick veneer, or by sawing into thin stuff and then planing both surfaces. The blanks *A* are then cut from this material, of the proper width and length, the ends dentated, as shown at *a a*, by means of a series of circular saws placed close together upon an arbor or other suitable tool, so that they will interlock when brought together. The recesses *b b* are then formed in its edges, at such points in its length as will bring them at the top and bottom of the frames when set up in the hive. These recesses form openings which allow space for the pas-

## Opinion of the Court.

sage of the bees between the frame, and for the ventilation of this part of the hive. Three triangular grooves, *c c c*, are then cut across the blank at such points in its length as will divide it into four nearly equal parts, each of which forms one side of the frame after the blank is bent into a quadrangular shape. These triangular grooves are cut nearly through the blank, sufficient wood only being left to hold the parts firmly together. As the sides of the grooves *c* are inclined toward each other at a right angle, it follows that, when the blank is bent into the form of a frame, these grooves make perfectly fitting interjoints at three of its corners, the fourth corner being that at which the ends of the blank are united to each other by means of the interlocking teeth formed thereon. In one of these spaces, between two of the grooves *c*, and preferably that which will form the top of the frame when placed in the hive, is formed a longitudinal groove, *d*, for the guide-strip, which makes a secure point of attachment for the comb, when the bees begin to build in the frames set side by side in the hive, with the parts of the frame containing the recesses *b b* at top. These frames meet a want long felt by bee-keepers, as those in common use are either dovetailed or nailed together at the corners, and, if set up at the manufactory, form a large bulk for transportation, and are very liable to breakage in handling; but, if sold to the user in pieces, to be put together by him, the numerous joints to be made cause loss of time and produce a very fragile article when finished, which loses its rectangular shape with the slightest rough usage, as the joints at the corners lack the necessary strength and rigidity to hold them in shape. My frame will be found to possess none of the above-named defects, as it is intended for transportation in solid packages before being set up; and, when set up, possesses great strength and rigidity, preserving its form without difficulty during all the rough handling to which such frames are frequently subjected. Having thus described my invention, I claim as new, and desire to secure

## Opinion of the Court.

by letters patent, the following: As a new article of manufacture, a blank for honey frames formed of a single piece of wood, having transverse angular grooves *c*, longitudinal groove *d*, and recesses *b*, all arranged in the manner shown and described."

The answer sets up as defences non-infringement and want of novelty. After issue joined, proofs were taken on both sides, and the Circuit Court, on a hearing, dismissed the bill. Its decision is reported in 21 Fed. Rep. 328.

The plaintiff does not carry his invention further back than the summer or late spring of 1877. The answer sets up that the same invention as that patented was known to Alexander Fiddes, who resides at Centralia, in the State of Illinois, as early as May or June, 1873.

The Circuit Court, in its decision, said that if the patentee was entitled to claim the blank for honey frames as a new and useful device, it was because it is a constituent of the frame or section into which it is formed by bending, no matter who bends it, whether the maker or purchaser for use; and that, if the state of the art at the date of the alleged invention was such that the patentee could not claim as his invention the honey frame or section when formed by bending and uniting the ends of such a frame, he, for the same reason, could not claim as his invention such a blank for the purpose of forming it into a frame or a section. The opinion then proceeded: "The question, therefore, is whether, upon the evidence, at the date of the alleged invention, the manufacture of honey frames or sections, by bending and uniting the ends of a blank consisting of a single piece, substantially as described in this patent, was a patentable novelty. Upon a careful comparison and consideration of all the evidence this question must be answered in the negative. Alexander Fiddes testifies to making and using honey sections formed from a single piece, grooved, bent, and united at the ends, as early as 1872 and 1873, some of which he sold to others for use; and if those now made by the complainant under his

## Opinion of the Court.

patent are superior in any respect to the first specimens of the manufacture, it is merely in point of finish and workmanship. There is no difference whatever in principle, and the early examples were complete and practical frames, actually used and perfectly serving the purpose, so that they cannot be considered as rude and imperfect experiments subsequently developed into a successful manufacture." We concur in these views of the Circuit Court.

In addition to this, the claim of the patent is as follows: "As a new article of manufacture, a blank for honey frames, formed of a single piece of wood, having transverse angular grooves *c*, longitudinal groove *d*, and recesses *b*, all arranged in the manner shown and described." The description in the specification states that "the invention consists, essentially, in forming the frame from a single blank, or piece of material having all the necessary grooves and recesses required to form a complete frame cut in it." It also says that, "in the drawings Fig. 1 is a plan of one of the blanks, showing the various recesses and grooves with which it is supplied." One of these grooves is the longitudinal groove *d*. The description further says: "In one of these spaces, between two of the grooves *c*, is formed a longitudinal groove, *d*, for the guide strip, which makes a secure point of attachment for the comb when the bees begin to build in the frames, set side by side in the hive, with the parts of the frame containing the recesses *b b* at the top." Thus the longitudinal groove *d* is made by the patentee a necessary element in the structure. The defendant's structure has no longitudinal groove, and no substitute or equivalent for it. *Fay v. Cordesman*, 109 U. S. 408 [15 Am. & Eng. 1]; *Yale Lock Mfg. Co. v. Sargent*, 117 U. S. 373 [16 Am. & Eng. 264]; *Dryfoos v. Wiese*, 124 U. S. 82 [17 Am. & Eng. 425.]

It is urged by the plaintiff that it is shown that the defendant's section is to be used with the comb foundation or attachment made by the putting, by the user, of pieces of wax on the section. But this is not a mechanical equivalent  
127 U. S. 180-181.



Notes and citations.

in the blank for the longitudinal groove, any more than, in Gage v. Herring, 107 U. S. 640 [14 Am. & Eng. 454], the person who shoveled or swept up, by manual labor, the meal deposited upon the floor of the dust-room, was a mechanical equivalent, in the sense of the patent law, for the automatic conveyor-shaft in the dust-room.

*The decree of the Circuit Court is affirmed.*

**Patent in suit:**

No. 243,674. J. Forncrook, Jr. June 28, 1881. Sectional Honey Frames.

---

---

**Cited:**

IN SUPREME COURT IN:

Fond du Lac County v. May, December, 1890, 137 U. S. 395.

---

---

---

IN CIRCUIT COURTS IN:

Perkins v. Eaton, December, 1889, 40 Fed. Rep. 672.

---

---

---





Syllabus.

GEORGE B. CORNELL, APPELLANT, v. PAUL WEIDNER.

127 U. S. 261-265. Oct. Term, 1887.

[Bk. 32, L. ed. 148; 43 O. G. 985.]

Argued, April 19, 1888. Decided April 30, 1888.

*Particular reissued patent construed and is void for unwarrantable enlargement.*

Reissued letters patent, No. 8759, granted June 17, 1879, to Lacy and Cornell, for Bushes for Bungs, adjudged invalid, as for an invention different from that of the original patent. The original patent, No. 118,617, August 29, 1871, and the first reissue, No. 5027, August 6, 1872, having been distinctly limited to a bushing having a notch, the second reissue, obtained nearly seven years afterward, for a bushing without any such notch, is an unwarrantable enlargement. (p. 557.)

[Citations in the opinion of the Court:]

Schumacher v. Cornell, 96 U. S. 549, 555 [11 Am. & Eng. 443]. p. 556.  
Yale Lock Mfg. Co. v. James, 125 U. S. 447, 464 [17 Am. & Eng. 603]. (p. 557).

Appeal from a decree of the Circuit Court of the United States for the Eastern District of Michigan, dismissing a bill for the infringement of a second reissue of letters patent.

The facts are stated in the opinion.

Messrs. J. W. MERRIAM and JOHN H. WHIPPLE, for appellant:

A plea in bar to the whole bill must reduce the issue to a single point.

Beams, Eq. 10; 1 Dan. Ch. 603, note 4; Rhode Island v. Massachusetts, 14 Pet. 261; Giant Powder Co. v. Safety Nitro Powder Co., 19 Fed. Rep. 513.

All other defence, except the one made by the plea, are cut off.

## Argument of counsel.

Walker, Patents, § 605; Pitts *v.* Hall, 2 Blatch. 229; Blandy *v.* Griffith, 3 Fish. Pat. Cas. 616.

The bill, so far as it is not contradicted by the plea, is admitted to be true.

Beams, Eq. 48; Story, Eq. Pl. § 694.

The identity of the invention set forth in the original and reissued patents is a matter of legal construction, on a comparison of the two instruments.

Seymour *v.* Osborne, 11 Wall. 516 [8 Am. & Eng. 290]; Stevens *v.* Pritchard, 10 Off. Gaz. 505; Kerosene Lamp Heater Co. *v.* Littell, 13 Off. Gaz. 1009; Tucker *v.* Tucker Mfg. Co., 4 Cliff. 397; Albright *v.* Celluloid Harness Trimming Co., 12 Off. Gaz. 228.

A comparison of the two patents, for the purpose of determining the question of identity of invention, requires an interpretation of the original patent in the light of the state of the art.

Eachus *v.* Broomall, 115 U. S. 429 [16 Am. & Eng. 176]; Vance *v.* Campbell, 1 Black, 427 [7 Am. & Eng. 117]; Garneau *v.* Dozier, 102 U. S. 230 [12 Am. & Eng. 545].

The notch in the flange was not an essential feature of the bush invention, but could be left out, and the essential characteristics of the invention remain unaltered.

Carver *v.* Braintree Mfg. Co., 2 Story, 439; Gong Bell Mfg. Co. *v.* Clark, 13 Off. Gaz. 275; Chicago Fruit House Co. *v.* Busch, 2 Biss. 472; Morey *v.* Lockwood, 8 Wall. 230 [8 Am. & Eng. 78]; Dorsey Harvester Rake Co. *v.* Marsh, 6 Fish. Pat. Cas. 398.

Under the circumstances shown in this case, there was no unjustifiable delay in applying for reissue 8759.

O'Reilly *v.* Morse, 15 How. 62 [5 Am. & Eng. 483]; Gage *v.* Herring, 107 U. S. 640 [14 Am. & Eng. 454]; Seymour *v.* McCormick, 19 How. 106 [6 Am. & Eng. 282]; Giant Powder Co. *v.* Safety Nitro Powder Co. 19 Fed. Rep. 512].

The patentee had a right to broaden the claim of the original in the reissue, to make it cover the actual invention.

## Opinion of the Court.

188 [12 Am. & Eng. 201]; Swain Turbine & Mfg. Co. v. Ladd, 102 U. S. 412 [13 Am. & Eng. 1]; Johnson v. Flushing & N. S. R. R. Co. 105 U. S. 539 [14 Am. & Eng. 19]; Coon v. Wilson, 113 U. S. 277 [15 Am. & Eng. 504].

There is no valid excuse for the long delay, and this delay is fatal.

Miller v. Bridgeport Brass Co. 104 U. S. 350 [13 Am. & Eng. 303]; Mahn v. Harwood, 112 U. S. 354 [15 Am. & Eng. 322]; Swain Turbine & Mfg. Co. v. Ladd, *supra*.

Mr. Justice GRAY delivered the opinion of the Court:

• This was a bill in equity for the infringement of a second reissue of letters patent. When the facts are understood, the case is clear.

The original patent, issued August 29, 1871, No. 118,617, was for an "improvement in metallic bushings for the bungs of casks, etc., and in wrenches for operating the same;" and described the bushing thus: "A tapering thimble or ring of metal, provided with a flange, *b*, at its larger end, and having a screw thread, *c*, on its outer surface, which screw thread is cast on the bushing in the mould, and is capable of immediate use without other finishing. The flange, *b*, is rounded off at its edge, and is provided at some point in its extent with a V-shaped notch, *d*, extending into the screw thread."

It then described the wrench and its mode of operation as follows: "E represents the wrench bar, consisting of the slotted plate *e* and the shank *f*. The metal of the shank, at its junction with the plate, forms a downward V-shaped projection, *l*, whose point extends forward toward the centre of the plate *e*. F represents a tapering core of metal, adapted to fit the bung bushing, *a*, and secured to the plate *e* by means of the bolt *h* and its nut. This core is made separable from the wrench bar, in order that, by providing a number of cores of different sizes, the same wrench may be used for bushing of different diameters. Provision is also made by the slot *k* for moving the bolt toward the angular projection

127 U. S. 261-262.

JOHN LACEY & GEORGE B. CORNELL.

Bush and Wrench for Barrels.

No. 118,617.

Patented Aug. 29, 1871.

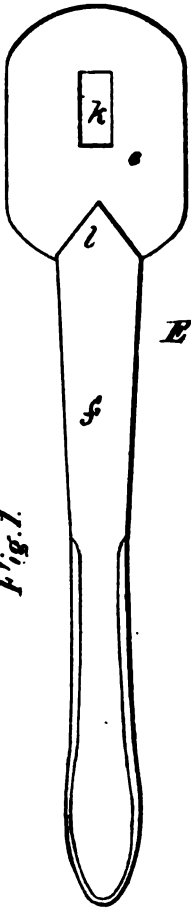

Fig. 1.

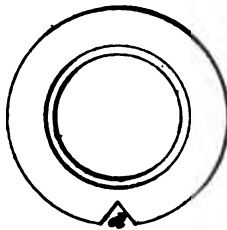

Fig. 2.

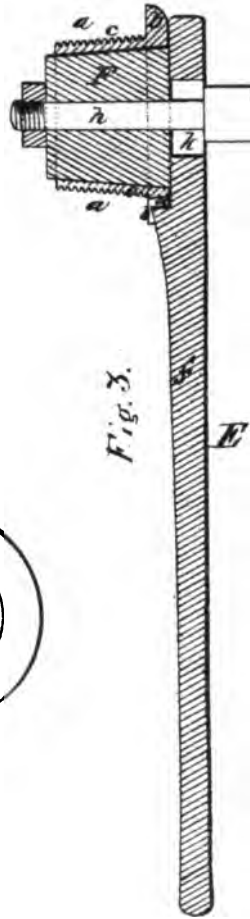
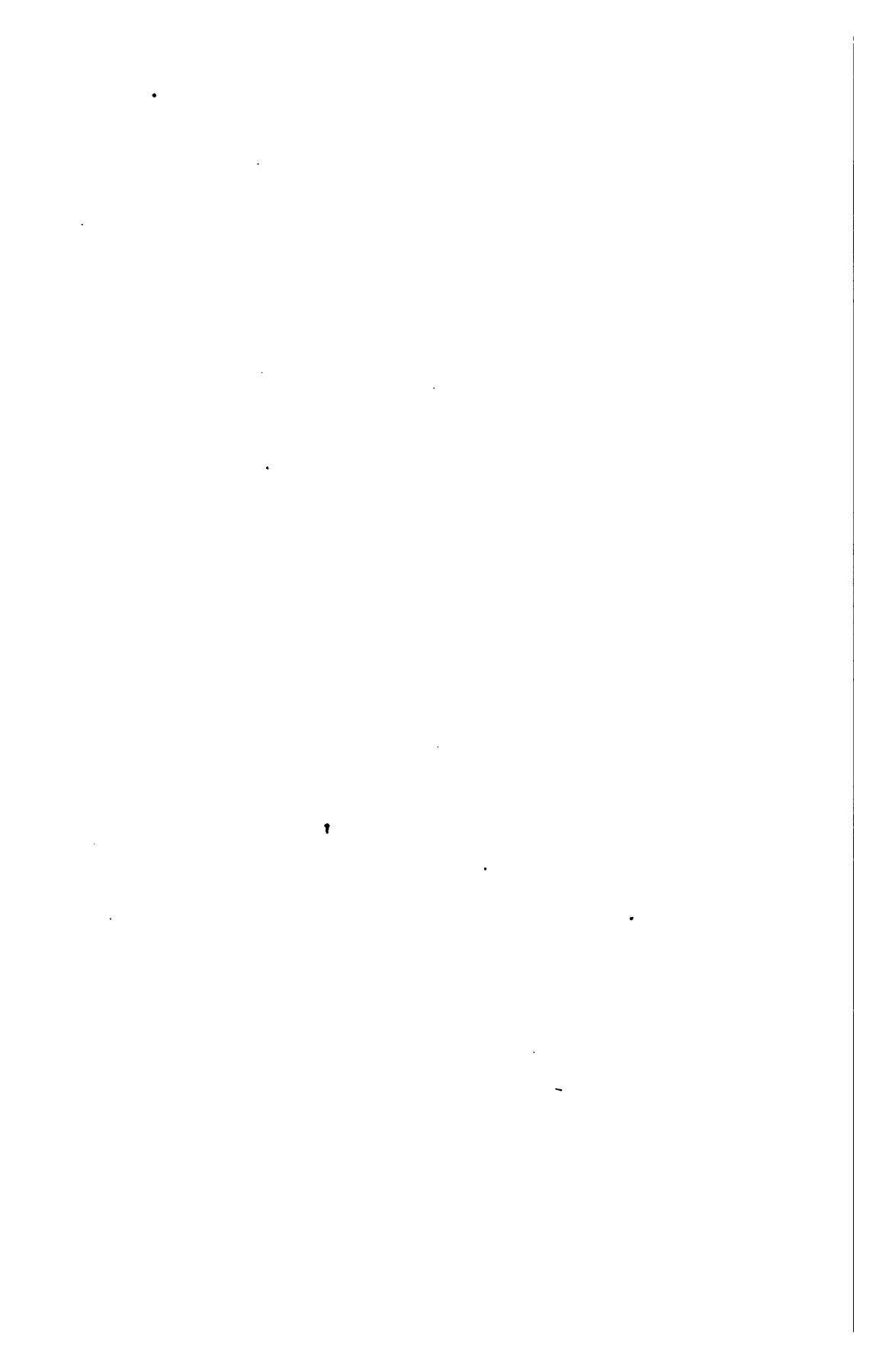

Fig. 3.

Witnesses.  
Villette Anderson  
E. H. Peated

Inventors  
Jno. Lacey,  
Geo B. Cornell,  
Chipman & Sonmuth  
Attys.



## Opinion of the Court.

*l*, which becomes necessary when a smaller core is substituted for a larger one.

“The wrench is applied by inserting the core into the opening through the bushing, and turning it until the projection *l* falls into the notch *d*. By means of the core the bushing is kept steady, and is readily prevented from assuming an oblique position in the bung opening; at the same time the operator is enabled to get a better hold on the bushing than by means of the wrenches in common use, which are apt to slip from their seats when used on such difficult work as turning a rough-cast screw into place.”

The single claim was in these words: “What we claim as our invention, and desire to secure by letters patent is:

“The combination, with the notched bung bushing, *a*, of the wrench, consisting of the bar *E*, having the slotted plate *e* and angular projection *l*, and the removable core *F*, substantially as specified.”

It thus appears that the original patent described a bushing with a V-shaped notch in the flange, and a wrench made with an angular projection to fit that notch, and applied by turning the wrench until the projection fell into the notch; and that all that the patentee claimed as his invention was the combination of the notched bushing with the wrench having a projection to fit it.

On August 6, 1872, the patent was reissued in two divisions, No. 5026 (not in this record) being for the wrench, and No. 5027 being for the bushing, describing it as “an angular ring of metal. This ring is made tapering on both its outer and inner sides, and is screw threaded upon its outer side, by which means the same is secured within the aperture in the cask. This thread may be formed by a suitable tool, or may be formed in the mould, as found most advantageous. The larger end of the said ring is provided with a flange *B*, the outer surface or periphery of which is made in an ovolo shape, and is provided with a V-shaped notch *d*, which extends inward to a point near the body of



## Opinion of the Court.

the ring. The object of this notch is to allow a suitable wrench, adapted for the purpose, to engage therewith, whereby the said bushing may be turned into place without the wrench slipping from its seat, as would be the case with a bushing having a smooth surface."

The claim in that reissue was for "the screw-threaded metallic bung bushing, made tapering upon both its outer and inner sides, and provided with the flange B having the V-shaped notch *d*, as and for the purpose described."

The specification and the claim of that reissue, as clearly appears upon its face, both treated the notch in the flange of the bushing as an essential element of the invention. Of the notch in that reissue it may be said, as this Court, in a case decided at October Term, 1877, said of the notch described in the reissue for the wrench, that it was "vital in the invention covered by his patent. The notch is the point of engagement between the bushing and the wrench, when the latter, operating as a lever, gives the former its circular motion, and thus forces it home. Without this arrangement such motion could not be communicated, and the desired result produced. Hence its importance in the scheme of the invention." *Schumacher v. Cornell*, 96 U. S. 549, 555 [11 Am. & Eng. 443].

On June 17, 1879, a second reissue, No. 8759, was obtained for the bushing, the material parts of the specification and the claim of which were as follows:

"Our invention relates to bushings for barrels; and consists of a short metallic tube in exterior form in shape of the frustum of a cone, slightly tapering. The outer surface is screw-threaded, to adapt it to be screwed forcibly into the bung hole of the barrel, and to be held securely in place by the contact of the surfaces. The larger end of this tube is provided with an angular flange projecting outwardly, and adapted to rest, when the bushing is screwed to its place in the hole of the barrel, snugly upon the outer surface of the stave. The interior surface of the bushing is also made in

127 U. S. 263-264.



560 MOSLER SAFE & LOCK Co. v. MOSLER, &c. [Sup. Ct.

Syllabus.

MOSLER SAFE AND LOCK COMPANY, APPELLANT, v. MOSLER, BAHMANN AND COMPANY.

127 U. S. 354-363. Oct. Term, 1887.

[Bk. 32, L. ed. 182; 43 O. G. 1115.]

Affirming *Ibid*, 22 Fed. Rep. 901; 31 O. G. 1689.

Argued, April 24, 25, 1888. Decided, May 14, 1888.

*Particular patents construed. Article and process of making it. Absence of invention. Aggregation.*

1. Letters patent, No. 283,136, granted August 14, 1883, to Moses Mosler, for an Improvement in bending Angle-Irons, adjudged invalid as being for a method of making the article described in the prior patent, No. 281,640. (p. 583.)
2. After a patent has been granted for an article described or made in a certain way, the inventor cannot afterward obtain a valid patent on an independent application for the method or process of making the article described in the earlier patent. (p. 583.)
3. The first and second claims of letters patent, No. 281,640, granted July 17, 1883, to Moses Mosler, for Improvement in Fire-proof Safes, for an Angle Bar for Safes, consisting of a right-angled iron bar, one of the sides of which is cut away (the cuts being curved and meeting a right angled cut), leaving a curve facing the uncut side, whereby said uncut side may be bent to form a rounded corner, *held* wanting in invention in view of the state of the art. The 3d claim *held* wanting in novelty. (p. 584.)
4. Letters patent, No. 273,585, granted March 6, 1883, to Moses Mosler, for an Improvement in Fire-proof Safes, adjudged invalid for lack of novelty, and because it was simply an aggregation of elements, to employ the same combination in round-cornered safes, which had been employed in square-cornered safes. (p. 584.)

Statement of the case.

[Citations in the opinion of the court:]

Hailes v. Van Wormer, 20 Wall. 353 [9 Am. & Eng. 340]. p. 583.

Reckendorfer v. Faber, 92 U. S. 347 [10 Am. & Eng. 373]. p. 583.

Pickering v. McCullough, 104 U. S. 310 [13 Am. & Eng. 238].  
(p. 583.)

Appeal from a decree of the Circuit Court of the United States for the Southern District of Ohio, dismissing a suit brought for the infringement of letters patent.

Opinion below in 22 Fed. Rep. 901.

The specifications and drawings of the Mosler letters patent, referred to in the opinion of the Court, are as follows:

MOSES MOSLER, OF CINCINNATI, OHIO.

FIRE-PROOF SAFE.

Specification forming part of Letters Patent, No. **273,585**, dated March 6, 1883; application filed February 5, 1883. (No model.)

*To all whom it may concern:*

Be it known that I, MOSES MOSLER, a citizen of the United States, residing at Cincinnati, county of Hamilton, State of Ohio, have invented certain new and useful Improvements in Fire-proof Safes, of which the following is a specification:

My invention relates to an improvement in fire-proof safes, the object being to provide an improved means of constructing the outer casing so that the safe may be filled from the bottom. With this object in view, my invention consists in certain details of construction and combination of parts, as will be hereinafter described, and pointed out in the claim.

In the accompanying drawings, Figure 1 is a vertical transverse section of a fire-proof safe embodying my improvements. Fig. 2 is an inverted plan view of the safe, showing

Statement of the case.

the removable bottom plate drawn out, or, rather, started into its place.

The front and back frames, A, of the safe are formed from angle-bars which have one side cut away where the bends are to be made and the uncut side bent around to close the joint in the corner and form a frame with its outer corners rounded. The meeting joint at the bottom of the frame is united by a short angle-piece, *a*, overlapping the joint on the inside and screwed or riveted to the frame A.

B is the sheet-metal cover, which is bent around the top sides and around the lower rounded corners of the frames. Upon each edge of the sheet B, between the angle-frames, are secured metal bars C, which project beyond the edges of the sheet B to form rests for the bottom plate D.

E is the customary sheet-metal box forming the interior receptacle. It is secured to the cast-metal door-frame in the usual manner.

The top of the caster-frame F conforms to the curve of the rounded corners, and after the plate D is pushed into its place the inner bolts which secure the caster-frames pass through the angle-frames and plate D.

I do not claim in this application the bent angle-frames, nor the safe composed of these frames and the sheet bent around them, the same being shown and claimed by me in a pending application.

What I claim as new, and desire to secure by letters patent, is—

The combination, in a fire-proof safe, of the frames A, sheet-metal cover B, bent around the top sides and lower corners, with bars C and lower removable plate D, substantially as specified.

MOSES MOSLER.

Witnesses:

CHAS. F. GESSERT,  
GEO. J. MURRAY.

(No Model.)

M. MOSLER.  
FIRE PROOF SAFE.

No. 273,585.

Patented Mar. 6, 1883.

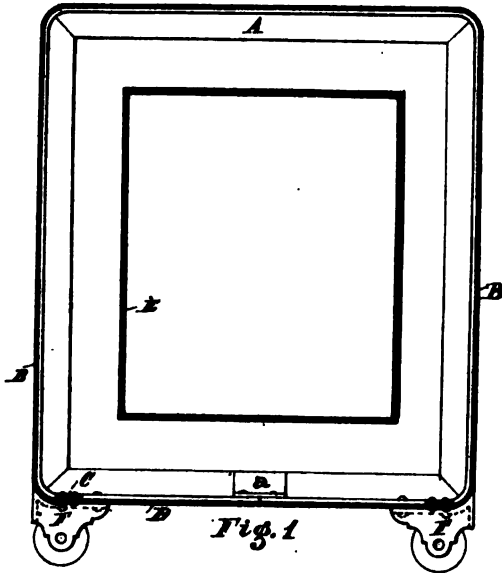

Fig. 1

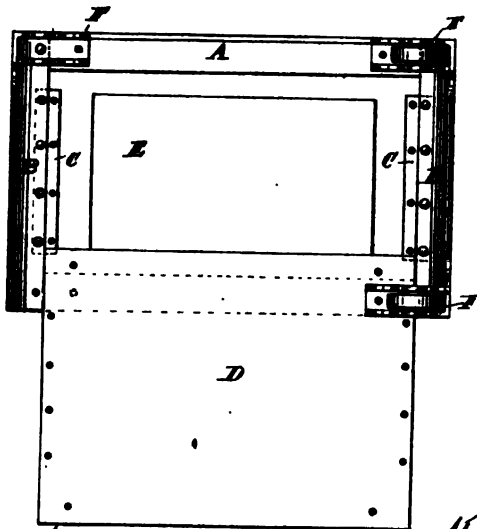
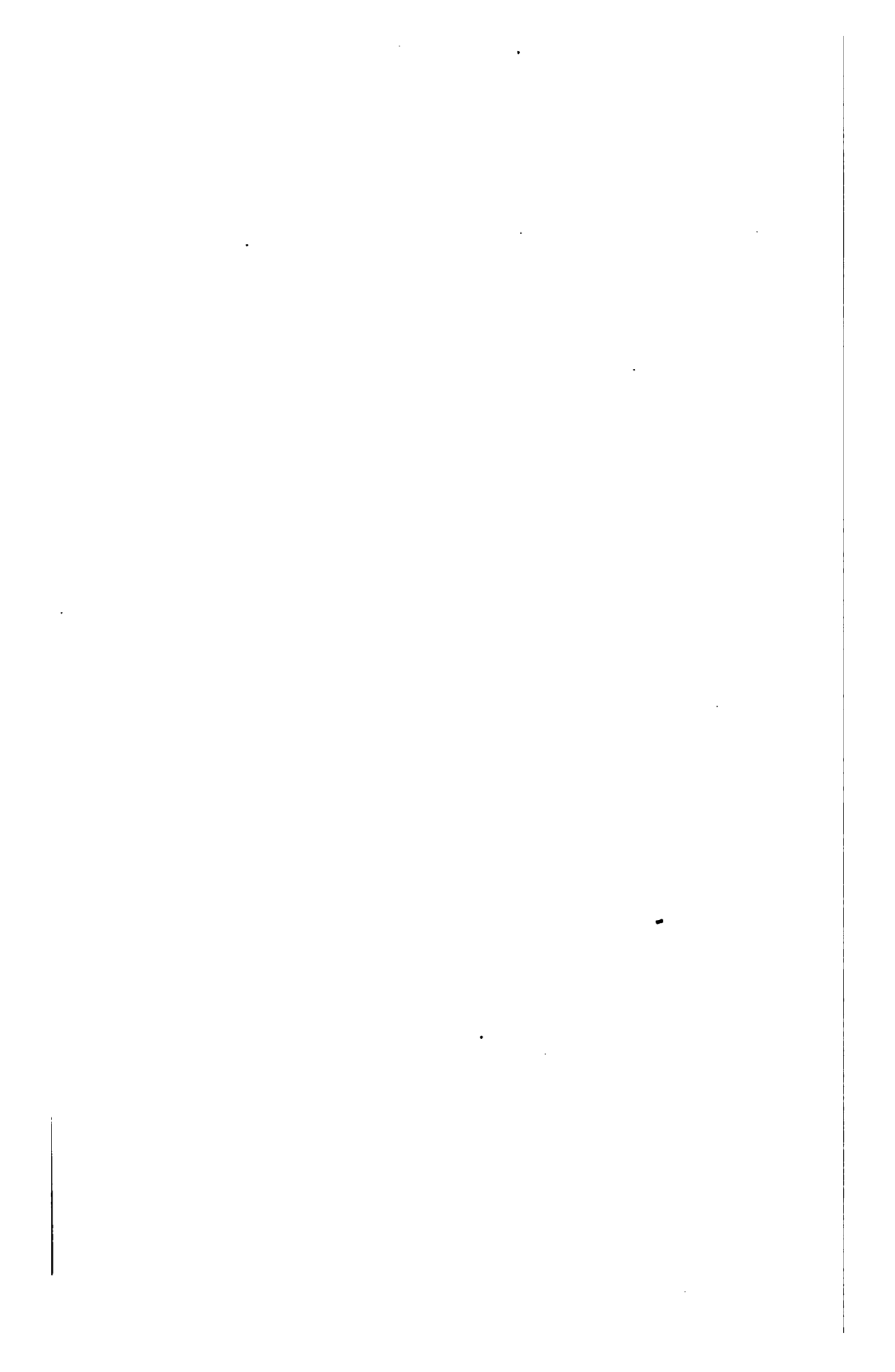

Fig. 2

Attest  
Chas. F. Gussert  
C. H. Hummel

Inventor  
Moses Mosler  
By Geo. J. Murray  
Att'y



## Statement of the case.

equal-sided L-shaped angle-bars A, which are bent around to the form shown in Fig. 3, and the ends united and firmly held by an angle-piece, *a*, which overlaps the joint upon the inside, and is secured to both sides of the angle-bar by rivets. To admit of the bar A being bent to the form shown, Fig. 3, and in dotted line, Fig. 1, one of its sides is cut out, where the bends are to be made, to the form shown at *a'*, Fig. 1. The joint-lines are angles of forty-five degrees with the opposite side of the angle-bar, the vertex of both angles being in the center of the thickness of the side to be bent. The curved ends *a*<sup>2</sup>, around which the side is bent, are described from the points *a*<sup>3</sup> in the miter-lines. The blank piece between these lines is punched out by a punch of suitable shape. The bend is made in a forming-press, the stationary die being the shape of the inner curve of the corner, and the movable die concaved to fit the outer curve, or vice versa. By this means the miter-lines are brought together and the outer angle of the bar A, at the corners, is bent down to form a close joint with the curved portions. The corner-joints are made more secure by re-enforce pieces B, made of malleable cast metal to snugly fit into the corners, and secured therein by riveting or other well-known means. One of these pieces is shown secured in place in Fig. 3. The cast-metal door-frame C, with sheet-metal box D attached, is secured to the inside of the front angle-bar A in the usual manner. The sheet-metal cover E is bent around the frames formed of bars A, the ends of the sheet terminating under the safe. Upon each edge of sheet E, between the angle-frames, are secured metal bars F. One-half of these bars project beyond the edges of the sheet to form seats for the bottom sheet or plate, G. The sheet E projects over the rear frame the thickness of the back plate, H, the outline of which corresponds with the outline of the rear angle-frame. After the frame is secured together the safe is filled through the bottom opening with fire-proof cement. The bottom is then secured in place, and the casters, which have their upper



(No Model.)

M. MOSLER.  
FIRE PROOF SAFE.

No. 281,640.

Patented July 17, 1883

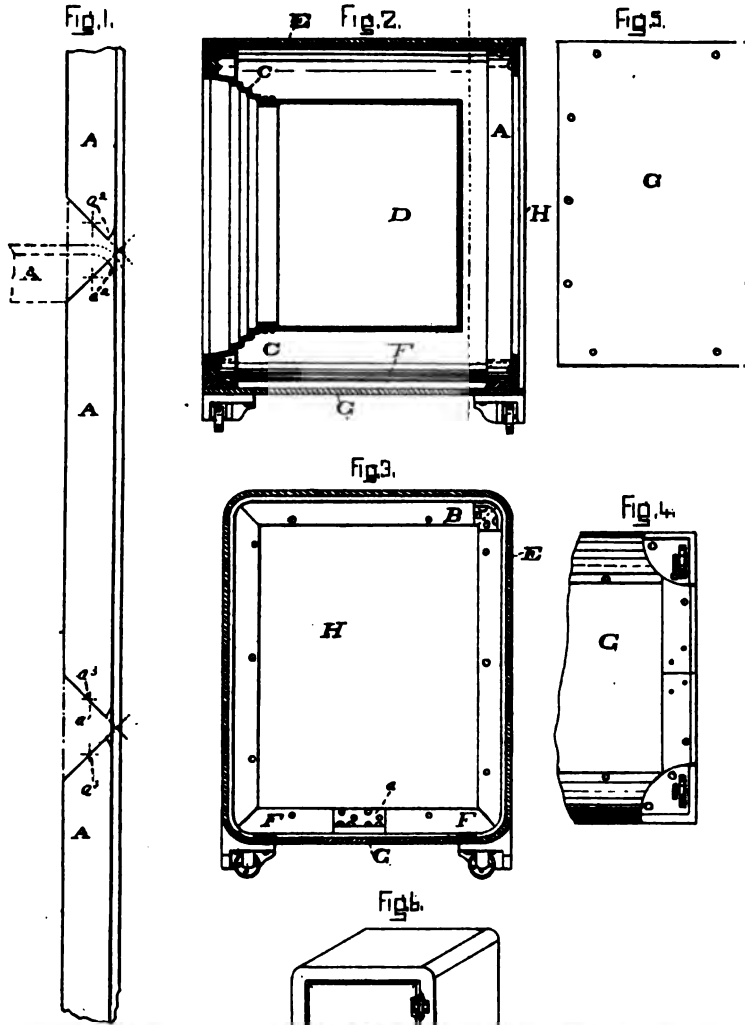

ATTEST  
*W. L. Dudley*  
*Alfred A. Benedict*

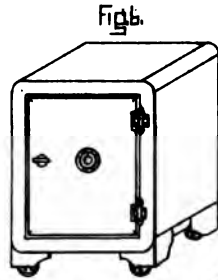

INVENTOR  
*Moses Mosler*  
By *Geo. J. ...*

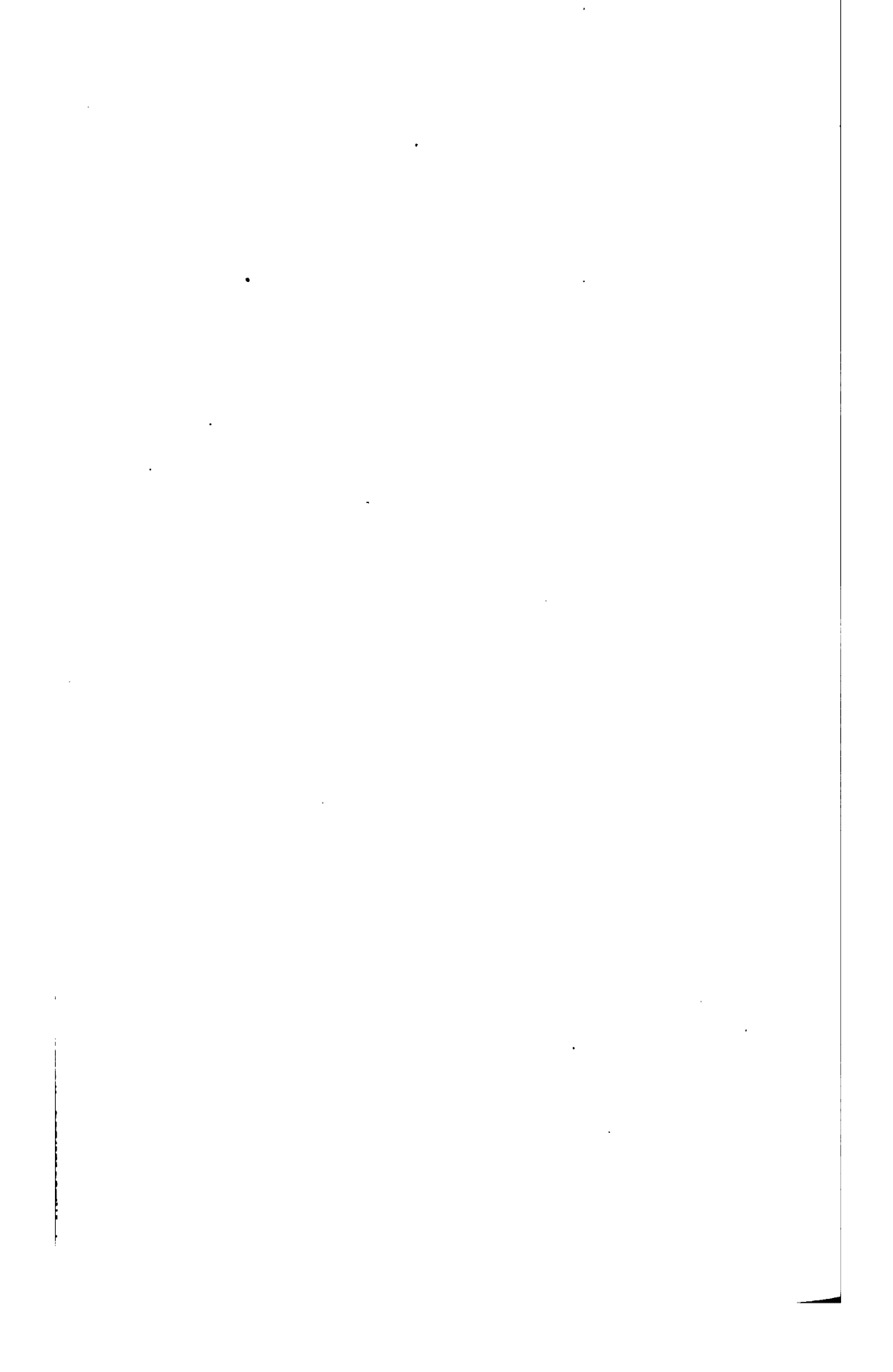

Statement of the case.

parts made to conform to the rounded corners of the safe, are attached.

It will be seen that in my safe there are no joints for the filling to work through, as is the case in safes formed of the welded and paneled frames now in common use, and that the exterior being plain smooth surfaces, the safe is much easier finished.

By the means above described I am enabled to use a stronger outer plate without increasing the cost, and if additional strength is required an additional frame, similar to the front and back ones, may be placed centrally between them. Thus all danger of the sides or top bulging out by the filling expanding is entirely avoided.

Instead of the bottom plate, the ends of sheet E may be made to meet under the bottom of the safe. In this case the safe is filled from the back, as is now done; but the form shown is much the best, as my safe can be completely finished before the filling is put in. The filling adds greatly to the weight. Much labor in handling is therefore saved.

It would be an inferior modification of my invention to bend the bar A so as to form the top and sides of the frame, and form the bottom by a separate straight angle-bar riveted to the inwardly-projecting sides.

I am aware that it has been proposed to make protecting corner-pieces for safes from angle-iron, from one side of which a triangular piece was cut out to permit the opposite side to bend.

The shape of the cut to permit the angle-bar to be bent to be bent to form rounded corners may be varied without departing from the principles of my invention, it only being essential that sufficient metal be cut away on one side of the angle-bar to permit the other or uncut side to be bent, the cut nearest the uncut side being in the form of a curve or curves, so that when said uncut side is bent to form the corner it will bear upon and be supported by the curved end

Statement of the case.

or portion of the cut, and thus be rounded by a curve similar to the curve of the cut.

What I claim as new, and desire to secure by letters patent, is—

1. An angle-bar for safe-frames, consisting, substantially as before set forth, of a right-angled iron bar, one of the sides of which is cut away, leaving a curve facing the uncut side, whereby said uncut side may be bent to bear upon said curve to form a rounded corner.

2. An angle-bar for safe-frames, consisting, substantially as before set forth, of a right-angled iron bar, one of the sides of which is cut away, with curved cuts meeting a right-angled cut, whereby the uncut side may be bent to form rounded corners.

3. In a safe, the combination of the front and back frames, formed of single bent angle-bars having one side cut away to leave curved ends, upon which the uncut side is bent to form rounded corners, and a metal sheet, E, bent around and secured to said frames to form the top and sides of the safe, substantially as described. MOSES MOSLER.

Witnesses:

GEO. J. MURRAY,  
M. W. OLIVER.

MOSES MOSLER, OF CINCINNATI, OHIO.

METHOD OF BENDING ANGLE-IRON.

Specification forming part of Letters Patent, No. **283,136**, dated August 14, 1883; application filed December 11, 1882. (No model.)

*To all whom it may concern*

Be it known that I, MOSES MOSLER, a citizen of the United States, residing at the city of Cincinnati, county of Hamil-



Statement of the case.

ton, State of Ohio, have invented certain new and useful Improvements in Bending Angle-Irons, of which the following is a specification :

This invention relates to a means for bending angle-bars. It consists in cutting away one web of the angle-bar opposite that portion of the uncut web which is to be bent to form a round corner, so as to permit the uncut web to bend freely, and the severed edges or portions to abut against each other when the angle-bar is bent.

In the accompanying drawings, in which similar reference-letters indicate like parts wherever they occur, Fig. 1 is a plan view of an angle-bar having one of its sides cut out to permit the uncut side to bend around the bar or corner, when bent being represented in dotted line. Figs. 2, 3 and 4 show in plan view different forms of openings or notches in one side of the angle-bar, which will permit the bar to bend and leave a close joint between the abutting edges as they are brought together to form a round cornered frame. Fig. 5 represents a templet of card-board or thin sheet metal, which I use to determine about the shape and size of the notch or cut which it is necessary to make to admit of the bar being bent to any desired angle, and to make a corner of any desired curve. Fig. 6 represents, in perspective, a simple device which I use to bend the bar to the desired shape.

A represents the uncut web, and B the cut web, of a right-angled angle-bar. The web B is cut away by a punching-tool of suitable shape in front of that portion of web A which is to be bent. As represented in Fig. 1, the outer opening, C, is made by lines at angles of forty-five degrees to the edge of the web, so that when the bar is bent the edges of this opening meet each other in a true miter. The inner opening, D, which permits the bar to bend, has a dove-tailed shape bounded by curved lines described from points upon the miter-line and the face of the uncut web A. The curved ends of the web B abut against the uncut side when the bar

## Statement of the case.

is bent, as represented in dotted line, Fig. 1, and in full line, Fig. 3; thus making a close joint.

Fig. 2 represents a corner formed by severing the web B with a cut, one edge of which is at right angles to the edge of the web, and the opposite edge by a circular cut, which is the same curve as the inner curve of corner, that portion of web B between these lines and web A cut away to permit the bar to bend, and the edge of web B upon side of the opening to be brought against the cut at right angles to edge upon the opposite side.

It is evident from an inspection of Figs. 3 and 4 that the shape of the opening or cut-away portions of web B may be varied at will, so long as the meeting line or lines be not extended beyond the space bounded by the rounded corner and the edge-lines extended to web A. The miter-line being taken as the central dividing-line, whatever shape is cut away from web B upon one side of this line, the counterpart must be left upon that part of the web upon the other side. If, for instance, the small circular projection shown in dotted line, Fig. 3, be left upon one side of the miter-line, a corresponding circular opening must be cut out of the web upon the opposite side of the line in this case, as well as in the form shown in full line, Fig. 4. The projecting piece must be bent back until the other parts are brought together, when it is driven into the opening, and locks the bar firmly together. I have shown in dotted line, Fig. 4, another form of joint similar to the one shown in Fig. 3.

The templet shown in Fig. 5 is a thin sheet-metal or cardboard angle-piece. One web of this I sever by a cut, *e*, at right angles to the edge *d* of one web. The two webs are severed at their junction for some distance upon each side of this line or cut *e*. Now, by bending the web B' so that the cut edges will pass each other the templet may be bent around to any curve desired and to any angle, the corners of the severed web passing underneath the uncut side and one part of web B' overlapping the other. When the templet

Statement of the case.

is bent to the proper angle and the corner of the size desired, it is secured in position, while the web B' is severed on a line with the inner curve of the corner, and another cut from the inner angle of the edges through the overlapping parts of the templet to any part of curved corner of web A'. When the templet is again straightened it will disclose the proper shape of opening, or of the punch to cut out angle-bars of the same width as the pattern to be bent to the desired angle.

The angle-bars cut out as described may be bent to the proper form by the machine represented in Fig 6. In this E represents a metal block having upwardly-projecting sides screw-tapped to receive clamping-screw F. The opposite corners of the block are rounded to fit the inner curve of the desired corner. G is a loose block of iron, between which and the side of block E the uncut web A is clamped by screw F, the other web, B, resting on the block, the cut-away part over the rounded corner; by force applied to the projecting end of the bar it is bent around until the severed edges meet in a close joint.

The angle-bar herein shown is not claimed here, as it is the subject of a pending application.

What I claim herein, and desire to secure by letters patent, is:

The herein-described process of bending angle-irons, which consists in cutting away a portion of one web by a cut which severs the two webs at their junction for a distance equal to the arc of the corner to be bent, and removes sufficient of metal in front of the single part of the uncut web to permit the same to bend to the desired angle, and to insure the edges of the opening meeting to form a close joint as the bar is bent, substantially as shown and described.

MOSES MOSLER.

Witnesses:

GEO. J. MURRAY,  
JOHN CRANE.



Argument of counsel.

The facts are stated in the opinion.

Mr. GEORGE J. MURRAY, for appellant:

If one with a knowledge of the state of the art surreptitiously attempts to appropriate to himself what he knows does not belong to him, he should be estopped against a person whom the Patent Office has decided—as against his claim—to be the original and first inventor.

*Greenwood v. Bracher*, 1 Fed. Rep. 856; *Peck, S. & W. Co. v. Lindsay*, 2 Fed. Rep. 688; *Hanford v. Westcott*, 16 Off. Gaz. 1181; *Holliday v. Pickhardt*, 12 Fed. Rep. 147; S. C. 22 Off. Gaz. 420; *U. S. & Foreign Salamander Felting Co. v. Asbestos Felting Co.* 18 Blatch. 312; *Shuter v. Davis*, 16 Fed. Rep. 564; *Russell v. Place*, 94 U. S. 606 [11 Am. & Eng. 226].

The decision of the officers of the Patent Office should not be reversed except upon most satisfactory proofs.

*McComb v. Ernest*, 1 Woods, 195; *Crouch v. Speer*, 6 Off. Gaz. 187.

The records of the interference case are competent to prove the validity and value of the inventions sued upon.

*Smith v. Goodyear Dental Vulcanite Co.* 93 U. S. 486 [11 Am. & Eng. 1]; *Hicks v. Otto*, 19 Fed. Rep. 749; *Shuter v. Davis*, *supra*; *U. S. Stamping Co. v. King*, 17 Blatch. 55; *Hoe v. Cottrell*, Id. 546; *Holliday v. Pickhardt*, 12 Fed. Rep. 147; *Consolidated Safety Valve Co. v. Crosby Steam Gauge & Valve Co.*, 113 U. S. 157 [15 Am. & Eng. 460]; *Webster Loom Co. v. Higgins*, 105 U. S. 580 [14 Am. & Eng. 70].

The burden of proof of want of novelty rests upon him who avers it, and every reasonable doubt should be resolved against him.

*Seymour v. Osborne*, 11 Wall. 516 [8 Am. & Eng. 290]; *Walker, Patents*, § 76 and cases cited; *Bates v. Coe*, 98 U. S. 31 [12 Am. & Eng. 150]; *Imhaeuser v. Buerk*, 101 U. S. 647 [12 Am. & Eng. 443].

## Opinion of the Court.

patents, and the contents of the specifications and claims, and we adopt its statement, as follows:

“1. No. 273,585; application filed February 5, 1883; letters dated March 6, 1883. The object of this invention, as stated in the specification, is to provide an improved means of constructing the outer casing, so that the safe may be filled from the bottom. The front and back frames of the safe are formed from angle bars, which have one side cut away, where the bends of the corners are to be made, and the uncut side bent around to close the joint in the corner, and form a frame with its outer corners rounded. The meeting joint at the bottom of the frame is overlapped by a short angle piece, which is screwed or riveted to the frame, uniting the joint. A sheet metal cover is bent around the top sides, and around the lower rounded corners of the frames. Upon each edge of this cover, at the bottom of the safe and between the angle frames, are secured metal bars, which project beyond the edges of the cover to form rests for the bottom plate. The safe is made with the customary sheet metal box forming the interior receptacle and secured to the cast metal door frame in the usual manner. The top of the caster frame conforms to the curve of the rounded corners, and, after the bottom plate is pushed into its place, the inner bolts which secure the caster frames pass through the bottom plate which they secure and the angle frames. The patentee does not claim the bent angle frames nor the safe composed of these frames and the sheet metal cover bent around them (the same being shown and claimed by him in an application then pending), but limits his claim to the combination, in a fire-proof safe, of the frames, a sheet metal cover, bent around the top sides, and lower corners, with projecting metal bars, and removable bottom plate, substantially as described.

“2. No. 281,640; this patent differs from No. 273,585 in that a particular description is given, in the specification, of the cuts in the side of the angle bar, where the bends are to be made; but the patentee specifies that the shape of the

127 U. S. 356-357.

## Opinion of the Court.

the edges of this opening meet each other in a true miter. The inner opening, D, which extends outward within converging curved lines from the angle of the bar to where it meets the opening C, extending inward from the edge of B, and within converging lines (the letter X suggesting the shape of the entire opening, excepting that the outer opening extends nearly to the angle of the bar), has a dove-tailed shape, bounded by curved lines described from points upon the miter line and the face of the uncut web A. The curved ends of the web B abut against the uncut side when the bar is bent, making a close joint. The patentee states in the specification, that 'the shape of the opening or cutaway portions of web B may be varied at will, so long as the meeting line or lines be not extended beyond the space bounded by the rounded corner, and the edge lines extended to web A.' The angle bars cut out as described, it is stated in the specification, may be bent to the proper form by the machine represented by Fig. 6 in the accompanying drawings. 'In this, E represents a metal block having upwardly projecting sides screw tapped to receive clamping screw F. The opposite corners of the block are rounded to fit the inner curve of the desired corner. G is a loose block of iron, between which and the side of block E the uncut web A is clamped by screw F, the other web, B, resting on the block, the cutaway part over the rounded corner; by force applied to the projecting end of the bar it is bent around until the severed edges meet in a close joint. The angle bar herein shown is not claimed here, as it is the subject of a pending application.'

"The safes described in these patents are filled through the bottom opening with fire-proof cement. The bottom is then secured in place and the casters attached. The patentee states in the specification forming part of the letters No. 281,640, that before his invention safes were filled from the back, and that his safe 'can be completely finished before the filling is put in. The filling adds greatly to the weight. Much labor in handling is therefore saved.'"

## Opinion of the Court.

templet as a pattern is nothing new. It is clearly shown by the testimony, that cutting an opening in one web of an angle bar to permit the bending of the bar to an angle or curve was known and used before the date claimed by complainant's assignor for his invention. Different shapes of cuts and openings are shown in exhibits put in evidence by respondents. Unless the precise cuts and shape of opening shown in the drawing attached to the specification forming part of the letters patent are patentable, the claims are worthless. But the patentee shows how, by the use of a pattern of flexible material—an old method, and familiar as the use of the carpenter's miter box—he determines the lines of the cuts and the shape of the opening. In this there is no exercise of the inventive faculty; it is only what would occur to a mechanic of ordinary skill. Moreover, if the precise lines of cuts and shape of opening shown in the drawings were patentable, the patentee does not, as we have seen, so limit his claim, but seeks to cover variations, which he says may be made without departing from the principle of his invention. Claims 1 and 2 in letters patent, No. 281,640, and the claim in letters patent, No. 283,136, are therefore adjudged to be invalid.

“As to the combination claim, being the only claim in letters patent, No. 273,585, and claim 3 in letters patent, No. 281,640, they are old, excepting only—and this is not material—that the precise lines of cuts and the shape of the opening of the angle bar are not found in safes of prior manufacture. The sheet metal cover is old. It is shown in respondent's exhibit. ‘St. Louis Safe.’ The bars C and lower removable plate D, claimed in No. 273,585, are old. See respondent's exhibit A and the deposition of John Hurst. The safes in the manufacture of which they were used were square cornered, as was then the fashion, but that is not material. When the angle frames were bent the corners were round, and then heated and hammered upon both sides of the corners, to make them square. Respondent's

127 U. S. 360-361.

## Opinion of the Court.

ing it so as to produce the identical article covered by the previous patent, which article was described in that patent as produced by the method or process sought to be covered by taking out the second patent.

The Circuit Court, in its opinion, said that the use of the templet shown in Fig. 5 of No. 283,136, as a pattern, was not new; that cutting an opening in one web of an angle bar, to permit the bending of the bar to an angle or curve, was known and used before the date of the patentee's invention; that different shapes of cuts and openings were shown in exhibits put in evidence by the defendant; that the claims in question, namely, claims 1 and 2 of No. 281,640, and the claim of No. 283,136, were invalid, unless the precise cuts and shape of opening shown in the drawings were patentable; that there was no exercise of the inventive faculty in using a pattern of flexible material, in an old and familiar method, to determine the lines of the cuts and the shape of the opening; and that the patentee had not limited his claims to the precise lines of cuts and shape of opening shown in the drawings, but had stated, in the specification of No. 281,640, that the shape of the cut to permit the angle bar to be bent to form rounded corners might be varied without departing from the principle of the invention. We concur in the view that claims 1 and 2 of No. 281,640 and the claim of No. 283,136 are invalid for the reasons thus given.

As to the claim of No. 273,585 and claim 3 of No. 281,640, which are claims to combinations, the opinion of the Circuit Court states that those claims are old, except in the immaterial point that the precise lines of cuts and the shape of the opening in the angle bar are not found in safes of prior manufacture; that the sheet-metal cover is old, being shown in defendant's exhibit, "St. Louis Safe;" that the bars C and lower removable plate D, forming part of the claim of No. 273,585, are old, it being immaterial that the safes in the manufacture of which they were used were square cornered, the corners of the angle frames, when bent

Notes and citations.

having been round, and having been then made square by heating and hammering the metal on both sides of the corners; that fire-proof safes had been filled from the bottom as early as 1879; that, although the patentee was the first to employ the combination claimed in the manufacture of round-cornered safes, the change from square-cornered safes was only a change in form; and that the combination was nothing more than an aggregation, and fell within the rulings of this Court, in the cases cited, that such an aggregation was not patentable. We think these views are correct.

*The decree of the Circuit Court is affirmed.*

127 U. S. 363.

**Notes :**

4. Aggregation :

- Hailes v. Van Wormer, 20 Wall. 353 [9 Am. & Eng. 340].  
Reckendorfer v. Faber, 92 U. S. 347 [10 Am. & Eng. 373].  
Rubber Coated Harness Co. v. Welling, 97 U. S. 7 [11 Am. & Eng. 479].  
Pickering v. McCullough, 104 U. S. 310 [13 Am. & Eng. 238].  
Packing Co. Cases, 105 U. S. 566 [14 Am. & Eng. 49].  
Tack Co. v. Two Rivers Co. 109 U. S. 117 [14 Am. & Eng. 571].  
Bussey v. Excelsior Mfg. Co. 110 U. S. 131 [15 Am. & Eng. 77].  
Stephenson v. Brooklyn Ry. Co. 114 U. S. 149 [16 Am. & Eng. 63].  
Beecher Mfg. Co. v. Atwater Mfg. Co. 114 U. S. 523 [16 Am. & Eng. 106].  
Hendy v. The Golden State, &c., 127 U. S. 370. (p. 588 *post.*)  
Watson v. Railroad Co. 132 U. S. 161.  
Royer v. Roth, 132 U. S. 201.  
Florsheim v. Schillinger, 137 U. S. 64.  
Fond du Lac v. May, 137 U. S. 395.  
May v. Juneau, 137 U. S. 408.  
Union Edge Setter Co. v. Keith, 139 U. S. 530.

Notes and citations.

---

---

**Patents in suit :**

273,585. M. Mosler. March 6, 1883. Improvement in  
Fire-proof Safes.

281,640. M. Mosler. July 17, 1883. Improvement in  
Fire-proof Safes.

283,136. M. Mosler. August 14, 1883. Improvement  
in Fire-proof Safes.

---

---

**Cited :**

IN CIRCUIT COURTS IN :

Eastern Paper Bag Co. v. Nixon, July, 1888. 35 Fed. Rep. 752.

---

---

---

IN DECISIONS OF COMMISSIONER OF PATENTS IN :

*Ex parte* Tainter, March, 1889, 47 O. G. 135.

---

---

---

IN TEXT BOOKS :

Robinson on Patents, 1890, § 466.

---

---

## Syllabus.

JOSHUA HENDY, APPELLANT, *v.* GOLDEN STATE  
AND MINERS' IRON WORKS, ET AL.

127 U. S. 370-376. Oct. Term, 1887.

[Bk. 32. L. ed. 207. 43 O. G. 1117.]

Affirming *Ibid*, 8 Sawy. 468.

Submitted May 3, 1888. Decided May 14, 1888.

*Particular patent construed. Absence of invention.. Aggregation.  
Infringement and Defence.*

1. Claim 1 of letters patent, No. 140,250, granted June 24, 1873, to Cusenbary and Mars, for an Improvement in Ore-Stamp Feeders, for "the feeding cylinder I mounted upon the movable timbers H, H, substantially as and for the purpose above described," construed to be for merely putting rollers under an article to make it movable when without the rollers it would not be movable, and held not to involve patentable invention. *Held*, further, there was no patentable combination between rollers which make the support movable and a feeding-cylinder mounted on such support. The union of parts was a mere aggregation (p. 592).
2. The defence of no patentable invention can be made without setting it up in an answer (p. 593).
3. The cylinder of claim 1 is "the feeding-cylinder I," and to be such cylinder must be a cylinder substantially as described, as having chambers or depressions, and the defendants' cylinder being smooth throughout, there was no infringement in this particular (p. 594).

[Citations in the opinion of the court:]

Atlantic Works *v.* Brady, 107 U. S. 192 [14 Am. & Eng. 380]. p. 593.Thompson *v.* Boisselier, 114 U. S. 1. [15 Am. & Eng. 549]. p. 593.Yale Lock Mfg. Co. *v.* Greenleaf, 117 U. S. 554 [16 Am. & Eng. 303].

p. 593.

Clark Pomace Holder Co. *v.* Ferguson, 119 U. S. 335 [16 Am. & Eng. 441]. p. 593.Dunbar *v.* Myers, 94 U. S. 187 [11 Am. & Eng. 59]. p. 593.



## Argument of counsel.

*Slawson v. Grand Street R. R. Co.* 107 U. S. 649 [14 Am. & Eng. 47].  
p. 594.

*Mahn v. Harwood*, 112 U. S. 354 [15 Am. & Eng. 322]. p. 594.

*Hailes v. Van Wormer*, 20 Wall. 353 [9 Am. & Eng. 340]. p. 594.

*Reckendorfer v. Faber*, 92 U. S. 347 [10 Am. & Eng. 373]. p. 594.

*Pickering v. McCullough*, 104 U. S. 310 [13 Am. & Eng. 238]. p. 594.

*Bussey v. Excelsior Mfg. Co.* 110 U. S. 131 [15 Am. & Eng. 77]. p. 594.

*Fay v. Cordesman*, 109 U. S. 408 [15 Am. & Eng. 1]. p. 594.

*Sargent v. Hall Safe & Lock Co.* 114 U. S. 63 [15 Am. & Eng. 573].  
p. 594.

*Shepard v. Carrigan*, 116 U. S. 593 [16 Am. & Eng. 235]. p. 594.

*White v. Dunbar*, 119 U. S. 47 [16 Am. & Eng. 397]. p. 594.

*Crawford v. Heysinger*, 123 U. S. 589 [17 Am. & Eng. 367], p. 594.

Appeal from a decree of the Circuit Court of the United States for the District of California, dismissing a suit for the infringement of letters patent.

Reported below in 8 Sawy. 468.

The facts are fully stated in the opinion.

Messrs. J. H. MILLER and J. P. LANGHORNE, for appellant:

The term "useful," when applied to inventions, means the opposite of hurtful, injurious, or frivolous. The degree of utility is immaterial.

*Lowell v. Lewis*, 1 Mason, 186; *Hoffheins v. Brandt*, 3 Fish. Pat. Cas. 218; *Cox v. Griggs*, 1 Biss. 362; *Tilghman v. Werk*, 1 Bond, 511; *Westlake v. Cartter*, 6 Fish. Pat. Cas. 519; *Many v. Jagger*, 1 Blatch. 372; *Wilbur v. Beecher*, 2 Blatch. 137; *Shaw v. Colwell Lead Co.* 11 Fed. Rep. 711; *Kneass v. Schuylkill Bank*, 4 Wash. 9; *Stanley v. Hewitt*, 17 Frank. Jr. 2d Series, 165; *Wintermute v. Redington*, 1 Fish. Pat. Cas. 239.

The appellees have used the invention and hence they are estopped to deny its utility.

*Simpson v. Mad River R. R. Co.* 6 McLean, 603; *Vance v. Campbell*, 1 Fish. Pat. Cas. 483; *McComb v. Ernest*, 1 Woods, 195; *Kearney v. Lehigh Valley R. R. Co.* 32 Fed. Rep. 320.

Mr. M. A. WHEATON, for appellees:

## Opinion of the Court.

The invention was an abandoned experiment.

Whiteley v. Swayne, 7 Wall. 685 [8 Am. & Eng. 70]; Howe v. Underwood, 1 Fish. Pat. Cas. 160; Swift v. Whisen; 3 Fish. Pat. Cas. 360.

A patent taken out by two parties, as joint inventors, for an invention which was made solely by one of the parties is void, and *vice versa*.

Walk. Pat. §§ 50, 51; Barrett v. Hall, 1 Mason, 447; S. C. 1 Robb, Pat. Cas. 234, 235; Stearns v. Barrett, 1 Mason, 153; S. C. 1. Robb, Pat. Cas. 115, 116, 117; Slemmer's Appeal, 58 Pa. 155; Ransom v. Mayor of N. Y. 1 Fish. Pat. Cas. 253.

The claim does not cover any patentable invention.

Pennsylvania R. R. Co. v. Locomotive Engine Safety Truck Co. 110 U. S. 490 [15 Am. & Eng. 148]; Bussey v. Excelsior Mfg. Co. Id. 131 [15 Am. & Eng. 77].

Mr. Justice BLATCHFORD delivered the opinion of the Court:

This is a suit in equity, brought by Joshua Hendy against the Golden State and Miners' Iron Works, a corporation, and six individual defendants in the Circuit Court of the United States for the District of California, for the infringement of letters patent, No. 140,250, granted June 24, 1873, to James D. Cusenbary and James A. Mars, for an "improvement in ore stamp feeders." The specification, claims, and drawings of the patent are as follows:

"Our invention relates to improvements in that class of ore feeders for quartz mills in which a pawl and ratchet are employed to operate the feeder automatically by the drop of the stamp. Our improvements consist, first, in mounting a feed cylinder upon a movable frame or truck, so that it can be readily shifted from place to place when it is desired to repair the mill; and, lastly, of an improved arrangement for operating the pawl rod by the drop of the stamp without the use of springs. In order to more fully illustrate and explain

127 U. S. 370-371.



## Opinion of the Court.

our invention, reference is had to the accompanying drawings, forming a part of this specification, in which Fig. 1 is a vertical section; Fig. 2 is a back view; Fig. 3 is a transverse section. A represents the frame of a stamp mill; B is the stamp; C is the stamp stem, with its tappet D; F is the cam shaft, and G the cam which lifts the stamp, all of which are arranged in the ordinary manner of constructing a stamp battery. H H are the foundation timbers upon which the feeding cylinder is mounted. These timbers are mounted upon rollers, so that the cylinder and frame can be moved about as desired. The cylinder I is made of cast metal, and has its outer surface formed into chambers or depressions, J J, which are separated from each other by longitudinal partitions, K. The cylinder and its carriage, when in working position, are placed below the hopper L, so that the ore from the hopper will fall into the chambers upon an inclined apron, M, which directs it beneath the stamp. This feeding cylinder, being made of cast metal, will not wear out like the endless belts heretofore used in this class of machines, and, as it turns upon journals, like any common roller or cylinder, it cannot become clogged, as the endless belt is liable to do. To one end of the cylinder a ratchet wheel N is secured, and this ratchet wheel is operated by, a pawl bar, O, to revolve the cylinder. In order to operate the pawl bar from the tappet, a horizontal shaft, *p*, has its opposite ends supported in boxes, which are secured to the sides of the upright timbers of the frame, so that the shaft will pass across directly in front of the tappet, transversely to the movement of the stamp stem. A fixed arm, *q*, extends backwards from the shaft *p*, so that its extremity will terminate below the tappet, in position to receive a blow from it when the stamp falls. Another fixed arm, *r*, extends forward from the shaft directly over the ratchet wheel, and to the extremity of this arm the upper end of the pawl bar *o* is attached by means of a trunnion block, *t*. This bar extends down to the middle of the periphery of the ratchet wheel, and has

## Opinion of the Court.

one or more upward projecting teeth on its lower end, which serve to engage with the teeth of the ratchet when the pawl is lifted by the rock shaft, and thus rotate the feeding cylinder. It will therefore be evident that, at each drop of the stamp, the tappet will strike the arm *q* and carry it downward, thus giving the shaft *p* a rocking motion, the weight of the pawl and its arm *r* serving to rotate the shaft in an opposite direction, thus feeding the ore automatically when it is needed. When there is a sufficient quantity of ore beneath the stamp, the drop will not be sufficient to operate the cylinder; but when the quantity of ore beneath the stamp is reduced, the drop is greater, and consequently the tappet strikes the arm *q* and operates the cylinder.

“ Having thus described our invention, what we claim and desire to secure by letters patent, is :

“ 1. The feeding cylinder I, mounted upon the movable timbers H H, substantially as and for the purpose above described.

“ 2. The rock shaft *p*, with its fixed arms *q r*, in combination with the pawl bar *o*, ratchet wheel N, and feeding cylinder I, when arranged to be operated by the tappet D, substantially as and for the purpose described.”

The answer denies infringement, and sets up two patents on the question of novelty, and denies the utility of the invention. After replication, proofs were taken on both sides, and the Circuit Court, on a hearing, dismissed the bill.

(*a*) Infringement is alleged of only the 1st claim, namely, “ The feeding cylinder I, mounted upon the movable timbers H H, substantially as and for the purpose above described.” The specification states, in regard to the subject of the 1st claim, that the improvement consists “ in mounting a feed cylinder upon a movable frame or truck, so that it can be readily shifted from place to place when it is desired to repair the mill.” The specification speaks of the timbers H H as being the foundation timbers upon which the feeding cylinder is mounted, and it says that those timbers “ are

(*a*) 127 U. S. begins opinion here inserting “ after stating the case.”

## Opinion of the Court.

mounted upon rollers, so that the cylinder and frame can be moved about as desired." Therefore, "the movable timbers H H" of the claim are timbers made movable by being mounted upon rollers. The specification also states that "the cylinder I is made of cast metal, and has its outer surface formed into chambers or depressions, J J, which are separated from each other by longitudinal partitions, K."

It is contended, in defence, that claim 1 of the patent is really a claim only for making the timbers movable, by mounting them upon rollers, so as to be able to move the cylinder and frame about as desired, and that this required no exercise of any inventive faculty. This seems to be the purport of the invention, as stated in the specification. It is the movable character of the frame on which the feed cylinder is mounted, so that the cylinder and frame may be readily shifted from place to place, when repairs are desired, that is designated as the invention. When the mill is in operation, the movable feature is not brought into play. It is only when the mill is out of operation that the movable feature is to be used. The 1st claim does not appear to cover the functions or operation of the feeding cylinder I, as a part of the mill when in operation; and, interpreting it by its own language as well as by that of the description in the specification, it covers only the mounting upon rollers of the timbers which carry the feeding cylinder. Merely putting rollers under an article, so as to make it movable, when, without the rollers, it would not be movable, does not involve the inventive faculty and is not patentable. *Atlantic Works v. Brady*, 107 U. S. 192, 200 [14 Am. & Eng. 380]; *Thompson v. Boisselier*, 114 U. S. 1 [15 Am. & Eng. 549]. and cases there cited; *Yale Lock Mfg Co. v. Greenleaf*, 117 U. S. 554, 559 [16 Am. & Eng. 303]; *Clark Pomace Holder Co. v. Ferguson*, 119 U. S. 335, 338 [16 Am. & Eng. 441], and cases there cited.

This defence is one which can be availed of without setting it up in an answer. *Dunbar v. Myers*, 94 U. S. 187 [11

## Opinion of the Court.

Am. & Eng. 59]; *Slawson v. Grand Street R. R. Co.* 107 U. S. 649 [14 Am. & Eng. 475]; *Mahn v. Harwood*, 112 U. S. 354, 358 [15 Am. & Eng. 322].

Moreover, there is no patentable combination between the rollers which make the timbers movable and the feeding cylinder I, mounted upon the timbers. The union of parts is merely an aggregation. The feeding cylinder, mounted upon timbers which have rollers, operates no differently from what it does when mounted upon timbers which have no rollers. *Hailes v. Van Wormer*, 20 Wall, 353, 368 [9 Am. & Eng. 340]; *Reckendorfer v. Faber*, 92 U. S. 347, 357 [10 Am. & Eng. 373]; *Pickering v. McCullough*, 104 U. S. 310, 318 [13 Am. & Eng. 238]; *Bussey v. Excelsior Mfg. Co.* 110 U. S. 131, 146 [15 Am. & Eng. 77]. There is nothing patentable in the aggregation.

The defendants' machine has a smooth cylinder, and not a cylinder with chambers or depressions. The specification of the patent describes the cylinder I as having its outer surface formed into chambers or depressions, separated from each other by longitudinal partitions. The cylinder of claim 1 is "the feeding cylinder I," and, to be such cylinder, must be a cylinder substantially as described, and it is described specifically as having chambers or depressions. The claim cannot be construed to cover a cylinder with a smooth surface not formed into chambers. *Fay v. Cordesman*, 109 U. S. 408, 420, 421 [15 Am. & Eng. 1]; *Sargent v. Hall Safe & Lock Co.* 114 U. S. 63, 86 [15 Am. & Eng. 573]; *Shepard v. Carrigan*, 116 U. S. 593, 597, 598 [16 Am. & Eng. 235]; *White v. Dunbar*, 119 U. S. 47 [16 Am. & Eng. 397]; *Crawford v. Heysinger*, 123 U. S. 589, 606, 607 [17 Am. & Eng. 367].

*The decree of the Circuit Court is affirmed..*

Notes and citations.

**Notes :**

1. Aggregation :

See *The Mosler Safe and Lock Company v. Mosler, Balman & Co.* 127 U. S. 354. (p. 560, Ante.)

---

---

2. Defence of want of patentability can be availed of without setting it up in answer :

*Dunbar v. Myers*, 94 U. S. 187 [11 Am. & Eng. 59].  
*Slawson v. Railroad*, 107 U. S. 649 [14 Am. & Eng. 475].  
*Mahn v. Harwood*, 112 U. S. 354 [15 Am. & Eng. 322].  
See also *Hill v. Wooster*, 132 U. S. 683.

---

---

**Patent in suit :**

No. 140,250. J. D. Cusenbary and J. A. Mars. June 24, 1873. Improvement in Ore-stamp Feeders.

---

---

**Cited :**

IN SUPREME COURT IN :

*Royer v. Roth*, 132 U. S. 201.  
*Hill v. Wooster*, 1889, 132 U. S. 683.  
*Fond du Lac County v. May*, 1890, 137 U. S. 395.  
*Florsheim v. Schilling*, 1890, 137 U. S. 64.  
*May v. Juneau County*, 1890, 137 U. S. 408.

---

---







ST. PAUL PLOW WOR  
WILLIA

127 U. S. 27

[Bk. 32. I

Submitted, May 4

*Jurisdiction*

1. In the suit at bar, v contract, where bot ment were put in there is no doub<sup>t</sup> rights " and came section 689, Rev<sup>ist</sup> value in dispute.

[Citations in the opin  
Wilson v. Sandf  
Brown v. Shanr  
Dale Tile Mfg.

In error to th  
District of Mir  
in an action fo  
the plaintiff  
within a defi  
ters patent  
make and se  
On motio  
See 29 F  
The fact

Messrs.  
fendant i  
Defen  
in this

Argument of counsel.

motion to dismiss the writ, to prevent needless and oppressive delay. The Court has held this proper practice.

*Clark v. Hancock*, 94 U. S. 493; *Thomas v. Wooldridge*, 23 Wall. 283.

Section 700, Rev. Stat. U. S. is the only act providing for the review here of a civil cause where an issue of fact has been tried in the Circuit Court otherwise than by a jury.

*Boogher v. New York L. Ins. Co.* 103 U. S. 90; *Kearney v. Case*, 12 Wall. 275.

Unless the case at bar also comes under section 699, providing for appeals without regard to amount in controversy, there is no jurisdiction in this case.

*Elgin v. Marshall*, 106 U. S. 578; *Zeigler v. Hopkins*, 117 U. S. 686.

An action on a contract to recover license fees, agreed to be paid for the use of a patent, is not a case touching patent rights, or arising under the patent or copyright laws of the United States.

*Brown v. Shannon*, 20 How. 55 [6 Am. & Eng. 354]; *Albright v. Teas*, 106 U. S. 613 [14 Am. & Eng. 266]; *Wilson v. Sandford*, 10 How. 99 [5 Am. & Eng. 122]; *Hartell v. Tilghman*, 99 U. S. 547 [12 Am. & Eng. 250]; *Sizer v. Many*, 16 How. 98 [6 Am. & Eng. 189]; *Burr v. Gregory*, 2 Paine, 426; *Blanchard v. Sprague*, 1 Cliff. 288; *Hill v. Whitcomb*, 1 Holmes, 317; *Goodyear v. Union India Rubber Co.* 4 Blatch. 63; *Meserole v. Union Paper Collar Co.* 6 Blatch. 356; *Goodyear v. Day*, 1 Blatch. 565; *Brooks v. Stolley*, 3 McLean, 523; *Pulte v. Derby*, 5 McLean, 328; *Curt. Pat.* § 496; *Walk. Pat.* § 388.

The writ of error cannot be sustained on the ground that the Court went into the question of the validity of the patent.

*Kinsman v. Parkhurst*, 18 How. 289 [6 Am. & Eng. 273]; *White v. Lee*, 14 Fed. Rep. 789; *Rogers v. Riessner*, 30 Fed. Rep. 525; *Bartlett v. Holbrook*, 1 Gray, 114; *Marston v. Swett*, 66 N. Y. 206; S. C. 82 N. Y. 526; *Burr v. Duryee*, 2

## Opinion of the Court.

Fish. Pat. Cas. 285; Baltimore Car Wheel Co. *v.* North Baltimore Passenger R. Co. 21 Fed. Rep. 50; Walk. Pat. § 307.

Messrs. JOHN B. and W. H. SANBORN, for plaintiff in error, in opposition:

The pleadings put in issue the validity of the patents, and the novelty and utility of both. The Court tried and decided all these issues. Under this state of facts, this case was one arising under the patent laws of the United States.

Brooks *v.* Stolley, 3 McLean, 523; Littlefield *v.* Perry, 21 Wall. 205 [9 Am. & Eng. 446]; Bloomer *v.* Gilpin, 4 Fish. Pat. Cas. 54; Magic Ruffle Co. *v.* Elm City Co. 13 Blatch. 157; Woodworth *v.* Weed, 1 Blatch. 165; Wilson *v.* Sherman, Id. 538; Woodworth *v.* Cook, 2 Blatch. 160; Pulte *v.* Derby, 5 McLean, 336; Day *v.* Hartshorn, 3 Fish. Pat. Cas. 32; Goodyear *v.* Congress Rubber Co. 3 Blatch. 449; Blanchard *v.* Sprague, 1 Cliff. 288.

The plaintiff in error was not estopped to contest the validity of the patent.

Brown *v.* Lapham, 27 Fed. Rep. 77; Burr *v.* Duryee, 2 Fish. Pat. Cas. 275, 284; Moody *v.* Taber, 1 Ban. & Ard. Pat. Cas. 41-43; Bostock *v.* Goodrich, 25 Fed. Rep. 819; Bell *v.* McCullough, 1 Fish. Pat. Cas. 380; Wood *v.* Wells, 6 Fish. Pat. Cas. 385.

Mr. Justice GRAY delivered the opinion of the Court:

The original action was brought in the Circuit Court of the United States for the District of Minnesota by a citizen of Nebraska against a corporation of Minnesota, for breach of an agreement in writing, dated December 17, 1877, by which the plaintiff granted to the defendant the right to make and sell within a defined territory a certain kind of plow, under letters patent granted August 18, 1874, to the plaintiff for an improvement in plows (of which he alleged in his complaint that he was the first and original inventor), and the defendant agreed to make such plows in a good and workman-like manner, and to advertise and sell them at  
127 U. S. 376-377.

## Opinion of the Court.

Act of July 8, 1870, chap. 230, § 56, 16 Stat. at L. 207. The language applied to this subject in the Patent Act of 1836, under which the cases of *Wilson v. Sandford*, 10 How. 99 [5 Am. & Eng. 122], and *Brown v. Shannon*, 20 How. 55 [6 Am. & Eng. 354], were decided, was that used in that Act in defining the jurisdiction of the Circuit Court in patent cases, namely, "actions, suits, controversies and cases, arising under any law of the United States, granting or confirming to inventors the exclusive rights to their inventions or discoveries." Act of July 4, 1836, chap. 357, § 17, 5 Stat. at L. 124. Similar words were used in the Patent Act of 1861 in defining the jurisdiction of this Court. Act of February 18, 1861, chap. 37, 12 Stat. at L. 130. But in the Act of 1870, as in the Revised Statutes, Congress, while using similar language in defining the jurisdiction of the Circuit Court, substituted (it must be supposed, purposely) the new phrase, "touching patent rights," in defining the jurisdiction of this Court.

The present case was an action upon a contract by which the plaintiff licensed the defendant to make and sell a patented article, and not a suit for infringing the plaintiff's patent. But the questions whether that patent was valid, and whether it had been infringed, were put in issue by the pleadings, and decided by the Circuit Court. Whether, within the meaning of other statutes, and in the light of previous decisions, this case should be considered as "arising under" the patent laws of the United States, is a question not before us. See *Dale Tile Mfg. Co v. Hyatt*, 125 U. S. 46 [17 Am. & Eng. 508], and cases there cited. It is sufficient for the decision of this motion, that we have no doubt that a case in which the validity and the infringement of a patent are controverted is a "case touching patent rights," and therefore within the appellate jurisdiction of this Court, under § 699 of the Revised Statutes, without regard to the sum or value in dispute.

*Motion to dismiss for want of jurisdiction denied.*



## Statement of the case.

useful Improvements in Lead-Holders for Pencils, of which the following is a specification.

The object of my present invention is to hold the lead or crayon in pencils from slipping back within the tube when pressed upon by the act of writing, without danger of breaking the lead.

Lead-tubes now in common use are usually slotted at the lower end to form elastic clamping-fingers, which fingers are closed upon the lead near its point end by a sleeve or tube which moves longitudinally over the fingers. These fingers are either smooth upon the inside or terminate at their ends in sharp inward projections or claws. The first kind soon become so smooth that the lead slips back when borne upon in the act of writing; and the second frequently breaks the lead when the clamping-sleeve is tightened up, and when tightened up carefully the lead often breaks in use, when writing with the pencil inclined. I overcome both of these objections by making a fine screw-thread within the lower end of the tube before it is slotted to form the clamping-fingers.

In the accompanying drawings, Fig. 1 is an elevation of the lead-tube, detached from the case, and having the clamping-sleeve in position. Fig. 2 is a central vertical section of the lower part of the case and the lower end of the slotted lead-tube. The upper portion of the case and the lead-tube are shown in elevation. Fig. 3 is a longitudinal central section of the lower part of the lead-tube, greatly enlarged. In this view, as in Fig. 2, the clamping-sleeve is removed.

The lead-tube *A* is provided with three collars, *b*, *c*, and *d*.

To the collars *c* and *b* is secured a tube, *B*, and upon this is secured the outer finish of the case, as follows: The perforated lower cap, *C*, is soldered or otherwise suitably secured upon the lower end of said tube *B*. The outer shell, *D*, is slipped over the tube *B* until it strikes the lower cap, leaving the upper end of said tube *B* exposed to receive the





## Opinion of the Court.

slotted end of the tube to press the threaded fingers upon a lead, substantially as described.

JOHN HOLLAND.

Witnesses:

M. W. OLIVER,  
GEO. J. MURRAY.

The facts are stated by the Court.

Mr. GEORGE J. MURRAY, for appellant:

It is clear that defendants' device embodies the invention covered by the two claims of complainant's patent.

*Imhaeuser v. Buerk*, 101 U. S. 647 [12 Am. & Eng. 443]; *Bates v. Coe*, 98 U. S. 87 [12 Am. & Eng. 150]; *Blanchard v. Putnam*, 8 Wall. 420 [8 Am. & Eng. 107].

Complainant was entitled to a decree in accordance with the prayer of the bill.

*Sharon v. Hill*, 22 Fed. Rep. 28; *Peterson v. Simpkins*, 25 Fed. Rep. 486; *Coffin v. Ogden*, 18 Wall. 120 [9 Am. & Eng. 125].

Messrs. E. E. WOOD and EDWARD BOYD, for appellees:

A sale of the thing patented to an agent of the patentee, employed by him to make the purchase, on account of the patentee, is not, *per se*, an infringement.

*Byam v. Bullard*, 1 Curt. 100; Curt. Patents, 4th ed. § 300.

Mr. Justice GRAY delivered the opinion of the Court:

This is an appeal from a decree dismissing a bill in equity for the infringement of letters patent granted to the plaintiff January 22, 1884, for "improvements in lead-holders for pencils," which (omitting the drawings and the explanations of them) fully shows the invention claimed and the form of lead-holders or lead-tubes previously in use and known to the patentee, as follows:

"The object of my present invention is to hold the lead or crayon in pencils from slipping back within the tube when  
127 U. S. 397.

## Opinion of the Court.

pressed upon by the act of writing, without danger of breaking the lead.

“Lead-tubes now in common use are usually slotted at the lower end to form elastic clamping fingers, which fingers are closed upon the lead near its point end by a sleeve or a tube which moves longitudinally over the fingers. These fingers are either smooth upon the inside, or terminate at their ends in sharp inward projections or claws. The first kind soon become so smooth that the lead slips back when borne upon in the act of writing; and the second frequently breaks the lead when the clamping sleeve is tightened up, and when tightened up carefully the lead often breaks in use when writing with the pencil inclined. I overcome both these objections by making a fine screw thread within the lower end of the tube, before it is slotted to form the clamping fingers.

“The clamping fingers may, instead of being screw threaded upon the inside, be serrated or roughened to accomplish the same result; but the screw thread is much better, because by this means a uniformly-even roughened surface can be made within the lower end of the tube at comparatively small expense; and, as these pencils are designed to take the place of the common lead pencil, they must be made cheaply to insure their introduction into general use.

“I am aware that it is old to provide a pencil case for holding ordinary lead pencils with a sliding ring, to which are secured spring clamps having their holding surfaces serrated, and having their shanks bent to approach each other, then jut outwardly and downwardly at their free ends, so that a ring slide may be moved upon said shanks to cause the free ends of the clamps to grasp or release a pencil; and I am also aware that it is old to provide the lead-holding tube of a pencil with an interior thread and a single slot. I therefore do not claim either of these devices.

“I claim as my invention:

“1. As a new article of manufacture, a lead-tube for pen-

## Notes and citations.

cils, consisting, substantially as before set forth, of a tube provided at one end with internal or female threads and two or more longitudinal slots to form threaded fingers.

“2. The combination, with the lead tube provided at one end with internal threads and two or more longitudinal slots, of a clamping sleeve adapted to be adjusted upon the slotted end of the tube to press the threaded fingers upon a lead, substantially as described.”

It thus appears upon the face of the plaintiff's specification that there were already in use lead-holding tubes for pencils with two or more slots at the lower end, so as to form elastic clamping fingers, closing upon the lead by means of a sliding sleeve; as well as tubes with a single slot and an interior screw thread.

The slots, the screw thread within, and the outer sleeve being all old, and the combination of two or more slots with the sleeve, or of a single slot with the screw thread, being also old, it is too clear for discussion, that to make two or more slots in a tube threaded inside and sleeved outside required no invention; and it is therefore unnecessary to consider the evidence upon the question whether the plaintiff was the first person who did this.

*Decree affirmed.*

127 U. S. 398.

**Patent in suit:**

No. 292,313. J. Holland, January 22, 1884. Lead-holders for Pencils.

---

---

**Cited:**

IN SUPREME COURT IN:  
Hill v. Wooster, 132 U. S. 693.



Syllabus.

JACOB O. JOYCE, APPELLANT, *v.* CHILlicoTHE  
FOUNDRY AND MACHINE WORKS COMPANY  
ET AL.

127 U. S. 557-562. Oct. Term, 1887.

[Bk. 32. L. ed. 171. 44 O. G. 107.]

Affirming *Ibid*, 15 Fed. Rep. 260.

Argued January 26, 1888. Decided May 14, 1888.

*Particular patent construed, limited and not infringed.*

1. Claim 1 of letters patent, No. 154,989, J. O. Joyce, September 15, 1874, lifting-jacks for "a pawl for lever jack with two or more teeth, and adapted to move in inclined slots, grooves or guides formed in the frame, substantially as described," limited in view of the specification to a pawl moving by gravity alone in inclined slots, grooves or guides formed in the frame and *held* not infringed by a pawl mounted upon an incline, with a spring to press the pawl down the incline, assisted by gravity, and having no slots, grooves or guides formed in the frame. (p. 613.)

Appeal from a decree of the Circuit Court of the United States for the Southern District of Ohio, dismissing a suit for the infringement of letters patent.

Reported below in 15 Fed. Rep. 260.

The facts are stated by the Court.

Messrs. E. E. WOOD and EDWARD BOYD, for appellant:

We understand that the rule of law requires that to defeat a patent the same organization must be shown, operating in the same manner, and producing the same result substantially.

*Turrill v. Railroad*, 1 Wall. 491 [11 Am. & Eng. 235]; *Bates v. Coe*, 98 U. S. 31 [12 Am. & Eng. 150]; *Clough v. Barker*, 106 U. S. 176 [14 Am. & Eng. 211].

In the latter case the Supreme Court say, in speaking of

## Opinion of the Court.

objects are, first to substitute the weight of the pawl, sliding in inclined slots, grooves, or guides, for the elastic spring usually employed to press it against the teeth of the ratchet bar; and, second, to obtain greater strength by dividing the load among several teeth of the pawl and ratchet bar, instead of supporting it all on one tooth, as is commonly done.

"Fig. 1 of the accompanying drawings is a vertical section of so much of a jack as is necessary to show my improvements; and Fig. 2 is a modification of the same, in which the pins and slots of Fig. 1 are exchanged for the tongue and groove in Fig. 2.

"Referring to Fig. 1, A is the pawl, having teeth that engage with the teeth of the ratchet bar B. D D' are slots in the frame of the jack, inclined to the axis of the ratchet bar at the angle of about forty-five degrees, in which slots move the pins C C' of the pawl A.

"The operation is seen at a glance. When the ratchet bar is raised its teeth crowd or slide the pawl up the inclined slots out of the way, so as to allow it to pass, until it has traveled the length of a tooth, when the weight of the pawl causes it to fall back into the next tooth below, ready to hold the ratchet bar at the point gained, ready for another lift, and so on.

"In Fig. 2, instead of slots D D', there is a tongue, D, on each side of the pawl, with corresponding grooves in the frame of the jack, in which the said tongues move; or the tongues may be on the frame, with the grooves in the pawl; the tongues and grooves performing the same office that the pins and slots do in the form of construction shown in Fig. 1.

"Other modifications, involving the same principle of operation, may be possible; but I prefer the construction represented in Fig. 1, at the same time not limiting myself strictly to that, but claiming any equivalent arrangement by which the same objects are accomplished in substantially the same manner.

"I claim as my invention:

127 U. S. 558-560.

J. O. JOYCE.  
Lifting-Jacks.

No. 154,989.

Patented Sept. 15, 1874.

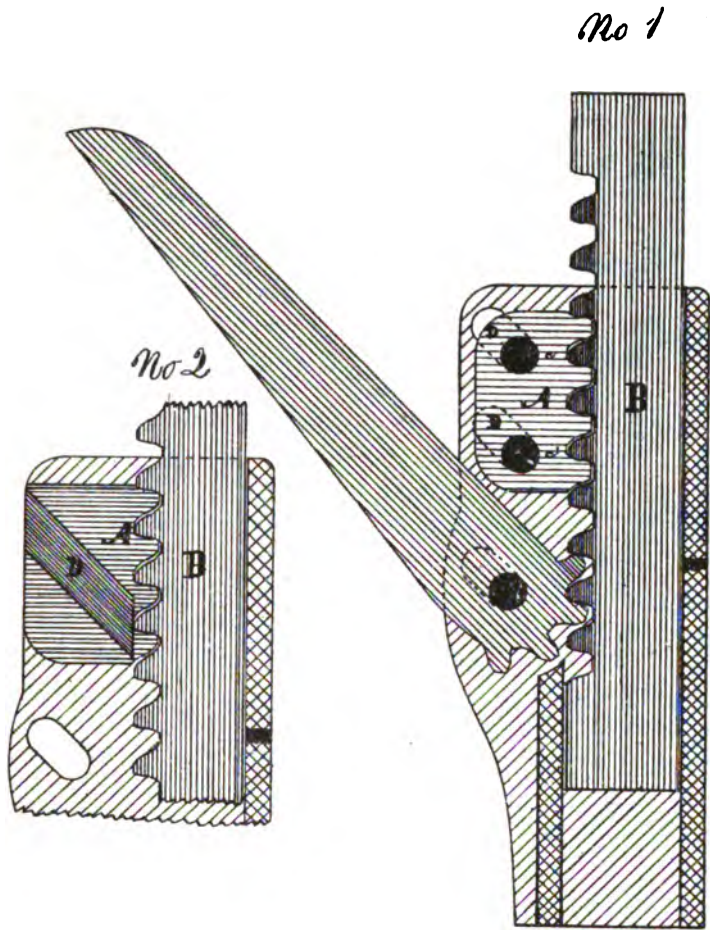

Witnesses.  
S. A. Goodwin  
Frank. S. Joyce.

Inventor  
Jacob. O. Joyce





Opinion of the Court.

"1. A pawl for lever-jack with two or more teeth, and adapted to move in inclined slots, grooves, or guides formed in the frame, substantially as described.

"2. The combination of the pawl A with its pins C C', slots D D', and ratchet bar B, substantially as described."

Each defendant put in a separate answer, alleging want of novelty, and setting forth sundry prior patents in which it was averred the invention was contained, and also giving the names of sundry prior inventors. Each answer denied infringement. The answer of the Company averred that it had made for its codefendant parts of lifting-jacks in accordance with letters patent of the United States granted to Samuel Mosler, No. 168,663, dated October 11, 1875; No. 172,471, dated January 18, 1876; and No. 194,711, dated August 28, 1877. Issue was joined and proofs were taken on both sides, and the Circuit Court dismissed the bill with costs. Its decision is reported in 15 Fed. Rep. 260.

In the opinion of the Circuit Court it is said: "The specification describes, and the drawings show, a frame with parallel sides, between which a pawl moves in parallel slots in the frame, forming guideways inclined toward the vertically-moving ratchet bar. The pawl is provided with a series of teeth on the face adjacent to the ratchet bar, and, at opposite sides, with projections or lugs engaging in the inclined slots of the frame. The guide slots are inclined at an angle of forty-five degrees or thereabouts, and the pawl is actuated solely by gravity to move down the inclines, and engage its teeth with those of the ratchet bar; and the patentee states, in his specification, as one of the objects of the invention, his purpose to utilize the gravity of the pawl itself, thus arranged as a substitute for a spring."

The clear statement of the specification in this respect is that the first object of the invention is "to substitute the weight of the pawl, sliding in inclined slots, grooves, or guides, for the elastic spring usually employed to press it against the teeth of the ratchet bar." The specification also

## Opinion of the Court.

says, that, "when the ratchet bar is raised, its teeth crowd or slide the pawl up the inclined slots out of the way, so as to allow it to pass, until it has traveled the length of a tooth, when the weight of the pawl causes it to fall back into the next tooth below, ready to hold the ratchet bar at the point gained, ready for another lift, and so on." These are plain statements, that the weight of the pawl, unaided by any spring, is to be used to cause the pawl to fall back into the next tooth below, after the ratchet bar has traveled the length of a tooth, such weight of the pawl being employed to press it against the teeth of the ratchet bar, in place of the use of an elastic spring for that purpose. The inclined slots, grooves, or guides formed in the frame, in which the pawl moves are the slots D D', made in the frame of the jack, and "inclined to the axis of the ratchet bar at the angle of about forty-five degrees," in which slots the pins C C' of the pawl move. The specification states that, instead of such slots in the frame of the jack, there may be grooves in such frame, one on each side of the pawl, in which a tongue on each side of the pawl moves; or there may be tongues on the frame and grooves in the pawl; the tongues and grooves performing the same office that the pins and slots do in the first form of construction.

In the opinion of the Circuit Court the following statement is made as to the defendants' jack, which we deem to be correct: "The defendants manufacture a jack having a many-toothed pawl resting at its bottom upon a seat slightly inclined toward the rack bar, and actuated by a spring placed behind it within the frame. The inclination of the seat is not sufficient to actuate the pawl by gravity, nor are there any slots or other means of guiding the pawl in the sides of the frame; the function of the inclined seat being rather to assist the spring in preventing a backward slip of the pawl when under pressure, than to facilitate the forward movement of the pawl, although to the latter result it may contribute in a slight degree."

## Argument of counsel.

granted March 14, 1876, to Thomas R. Bailey, Jr., for an improvement in hydrants.

Reported below in 22 Fed. Rep. 292.

The facts are fully stated in the opinion.

Mr. EDWARD J. HILL, for appellants :

It is the specification which governs and the drawings merely illustrate.

Hogg v. Emerson, 11 How. 587 [5 Am. & Eng. 279]; S. C. 6 How. 485 [5 Am. & Eng. 1].

This is a claim for a result or effect.

Case v. Brown, 2 Wall. 320 [7 Am. & Eng. 360].

The first claim of the reissue is identical with the second claim of the original.

Winans v. New York & E. R. R. Co., 21 How. 88 [6 Am. & Eng. 440]; Furbush v. Cook, 2 Fish. Pat. Cas. 668.

The claim is for the hydrant itself constructed and arranged as described.

Winans v. Schenectady & T. R. R. Co., 2 Blatch. 279.

The new parts are as distinctly pointed out by means of the words "with," "and with," as if separately numbered.

Tuck v. Bramhill, 6 Blatch. 95; Taylor v. Archer, 8 Blatch. 318; Silsby v. Foot, 14 How. 218 [5 Am. & Eng. 411]; Providence Rubber Co. v. Goodyear, 9 Wall. 795 [8 Am. & Eng. 150].

The record we proved by a sworn copy.

1 Greenl. Ev. § 496; Evanston v. Gunn, 99 U. S. 660.

The records are received in courts of justice as evidence of the facts stated.

Galt v. Galloway, 4 Pet. 343.

The original specification was clear enough to be understood by ordinary mechanics.

Hogg v. Emerson, 6 How. 473 [5 Am. & Eng. 1].

The sole question involved, one of fact, was forever settled by the Commissioner when he granted the reissue. Did he act erroneously? Then the only remedy was by interference

## Argument of counsel.

v. Broomall, 115 U. S. 429, 438 [16 Am. & Eng. 176]; Ives v. Sargent, 119 U. S. 652, 662, 663 [16 Am. & Eng. 512].

The law of the original structure must control; and no afterthought can convert the thing into what it was not normally designed to be.

Clough v. Barker, 106 U. S. 166 [14 Am. & Eng. 211]; American Bell Tel. Co. v. Dolbear, 17 Fed. Rep. 604, 605.

The testimony of a single witness cannot warrant a court of equity in finding for the complainant against the denial of defendant's answer.

Tobey v. Leonard, 2 Cliff, 40, 50, 51; Andrews v. Hyde, 3 Cliff, 516, 522; Carpenter v. Providence Wash. Ins. Co., 4 How. 185, 218; Grant v. Grant, 34 Beav. 623, 627.

He who has rights and sleeps upon them justly loses them.

Miller v. Bridgeport Brass Co. 104 U. S. 350, 352 [13 Am. & Eng. 303.]

The procurement of such reissue at so late a date, and after years of adverse practice, by others, was unjust, unlawful and fraudulent.

Matthews v. Boston Machine Co. 105 U. S. 54 [13 Am. & Eng. 501]; Bantz v. Frantz, 105 U. S. 160 [13 Am. & Eng. 542]; Gage v. Herring, 107 U. S. 640 [14 Am. & Eng. 454]; Clements v. Odorless Excavating Apparatus Co. 109 U. S. 641 [15 Am. & Eng. 44]; Turner & S. Mfg. Co. v. Dover Stamping Co. 111 U. S. 319 [15 Am. & Eng. 238]; Wollensak v. Reiher, 115 U. S. 96 [16 Am. & Eng. 162]; White v. Dunbar, 119 U. S. 47 [16 Am. & Eng. 397]; Newton v. Furst, & B. Mfg. Co. Id. 373 [16 Am. & Eng. 450]; Matthews v. Ironclad Mfg. Co. 124 U. S. 347, 351.

The rule *falsus in uno, falsus in omnibus* should be applied.

The Santissima Trinidad, 7 Wheat. 283, 339; Union Sugar Refinery v. Matthiesson, 3 Cliff. 639, 654.

The conduct of Thomas R. Bailey, Jr., must negative any attempt, at this distance of time, to establish a claim to such invention.

## Opinion of the Court.

*Atlantic Works v. Brady*, 107 U. S. 192 [14 Am. & Eng. 380.]

There is nothing in regard to which a witness is more likely to be mistaken than in fixing the date at which a transaction long past took place.

*Willett v. Fister*, 18 Wall, 91, 97; *Wing v. Richardson*, 2 Cliff. 449, 453; *Hawes v. Antisdell*, 2 Ban. & Ard. 10, 22; *Sinclair v. Backus*, 5 Ban. & Ard. 81, 83, 84.

Whenever a party desires to show that his invention was prior to his application for the patent, he must prove the fact by other sufficient evidence.

*Wing v. Richardson*, 2 Cliff. 449, 450; *Dane v. Chicago Mfg. Co.* 6 Fish. Pat. Cas. 130, 133; *Howard v. Christy*, 2 Ban. & Ard. 457, 458.

The application must fully disclose the invention.

*Chicago & N. W. R. Co. v. Sayles*, 97 U. S. 554 [12 Am. & Eng. 121]; *Eagleton Mfg. Co. v. West B. & C. Mfg. Co.* 18 Blatch. 218, 220, 222.

Usually the claim contains the words "as described" or "substantially as described," or words of like import, which are understood as referring back to the specification. Words of such import, if not expressed in the claim, must be implied.

*Mitchell v. Tilghman*, 19 Wall. 287, 391 [9 Am. & Eng. 174].

Mr. Justice BLATCHFORD delivered the opinion of the Court:

This is a suit in equity, brought in the Circuit Court of the United States for the Eastern District of Michigan, by James Flower, Thomas Flower, and George Flower, against the City of Detroit, the Fire Commission of the City of Detroit, Benjamin Vernon, President thereof, and the Board of Water Commissioners of the City of Detroit, for the infringement of reissued letters patent, No. 6990, granted March 14, 1876, on an application filed February 17, 1876, to Thomas R. Bailey, Jr., for an "improvement in hydrants," the original patent, No. 75,344, having been granted to said Bailey March 10, 1868. Among the defences set up in the answer, it was

## Opinion of the Court.

alleged that new matter, not constituting any substantial part of the alleged invention upon which the original patent was granted, was introduced into the specification of the reissue, and that the reissue is not for the same invention as the original patent, and is void.

The specifications and claims of the original and of the reissue are here placed side by side in parallel columns, the parts in each which are not found in the other being in *italic*.

*Original.*

“To all whom it may concern:

“Be it known that I, T. R. Bailey, Jr., of Lockport, in the county of Niagara, and State of New York, have invented a new and improved hydrant fire plug; and I do hereby declare *that* the following *is* a full, clear and exact description thereof, which will enable *those* skilled in the art to make and use the same, reference being had to the accompanying *drawings forming* part of this specification.

“This invention relates to a *new and improved method of constructing fire plugs or hydrants; and the invention consists in operating a cylinder valve in a suitable case, and in the arrangement and combination of parts connected therewith, as hereinafter described.*

127 U. S. 564-565.

*Reissue.*

“To all whom it may concern:

“Be it known that I, T. R. Bailey, Jr., of Lockport, in the county of Niagara, and State of New York, have invented a new and improved hydrant fire plug; and I do hereby declare the following *to be* a full, clear and exact description thereof, which will enable *others* skilled in the art *to which my invention relates* to make and use the same, reference being had to the accompanying *drawing, which forms a part of this specification.*

“This invention relates to *improvements in the construction of fire plugs or hydrants.*

T. R. Bailey Jr.  
Hydrant.

No 75344

Patented Mar. 10, 1868

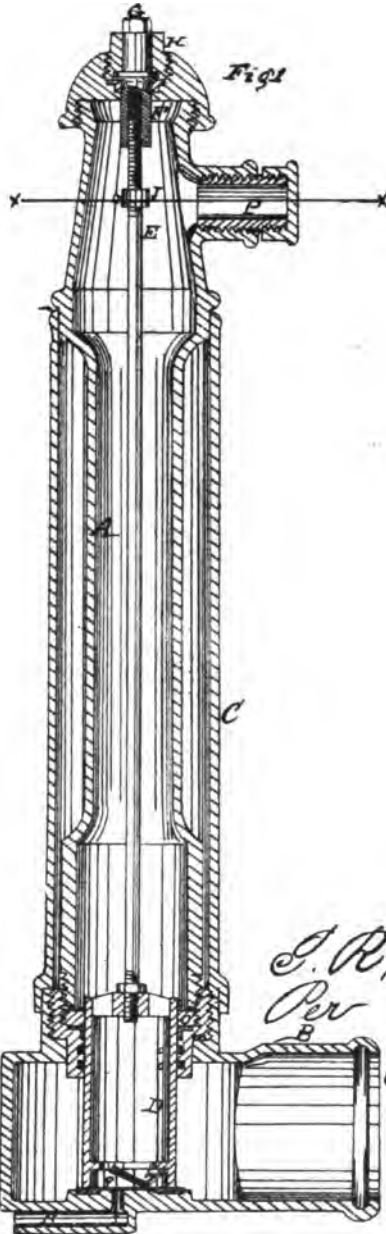

Witnesses  
Chas. Lusk  
H. Brown

T. R. Bailey Jr.  
Per Munnell  
Attorneys  
Inventor



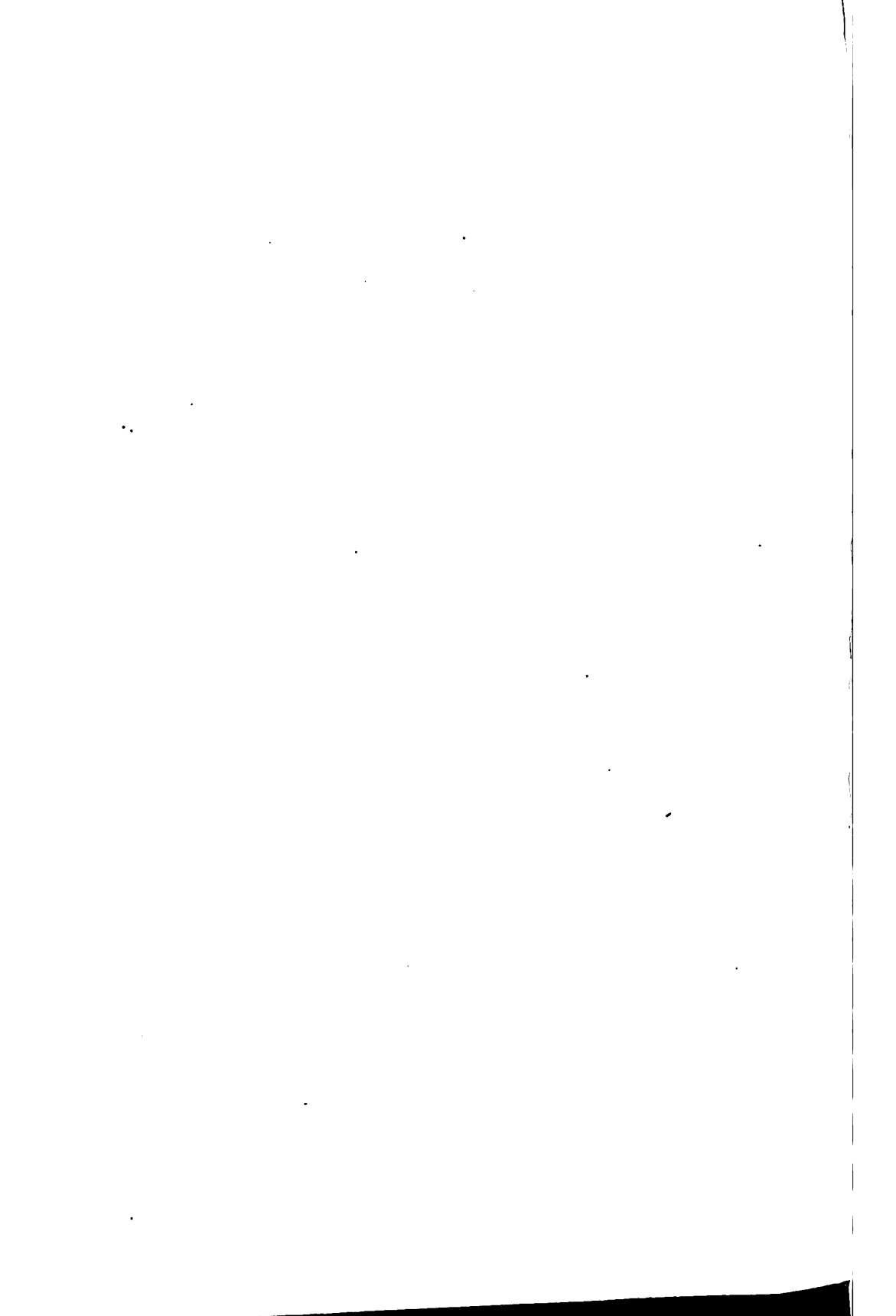

T. R. BAILEY, Jr.

HYDRANTS.

No. 6,990.

Reissued March 14, 1876.

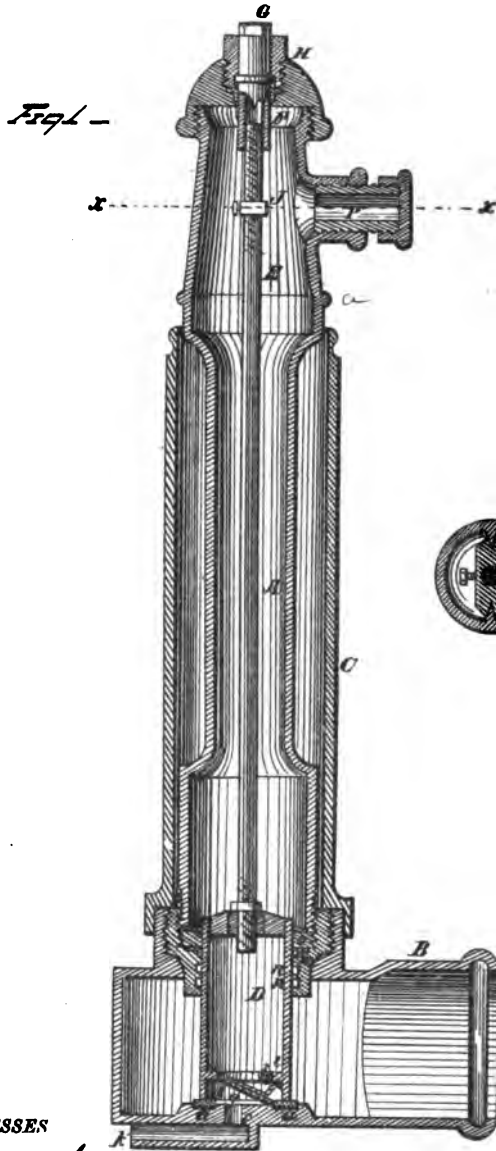

WITNESSES

*C. A. Stetingham*  
*Albert H. Knight*

INVENTOR

*T. R. Bailey Jr.*  
*N. J. Spurr & Co. Attorneys*

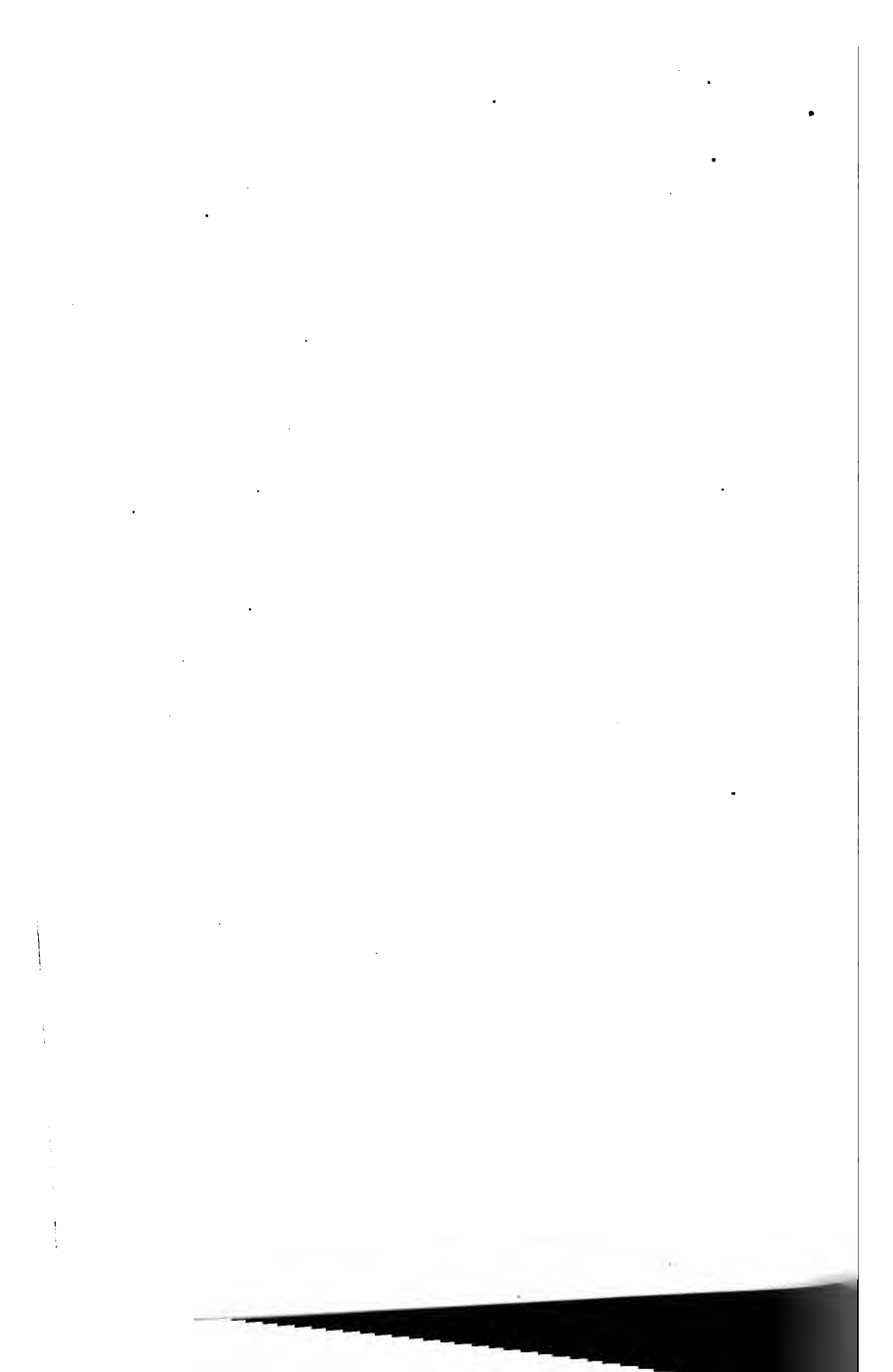

## Opinion of the Court.

"Fig. 1 represents a longitudinal central section of the hydrant, showing the parts of which it is composed and the manner of their arrangement. Fig. 2 is a cross section of Fig. 1 through the line x x.

"Similar letters of reference indicate corresponding parts.

"A represents the hydrant tube, from which the water is discharged. B is the horizontal section which is connected with the 'water main,' and which forms the valve chamber.

"C is a loose casing around the hydrant tube, for protecting the tube from dirt, etc. D is the cylinder valve, which has its seat at its lower end, on elastic or leather packing, secured in a groove, as seen in the drawing at a. E is a rod, having a screw thread on its upper end, by which the valve is operated. F is a sleeve nut, which engages with the screw on the rod, raising and lowering it as the nut is turned. This nut is turned by a wrench on the head G.

"The sleeve nut is secured

"In the drawing, Fig. 1 represents a longitudinal central section of a hydrant according to my invention:

"Fig. 2 a cross section of the same through lines x x of Fig. 1.

"My invention consists in the following parts and combinations, as hereinafter specified and claimed, wherein

"A represents the hydrant tube, from which water is discharged. B is the horizontal section which is connected with the water main, and which may form the valve chamber.

"C is a loose movable casing around the hydrant tube. D is the cylinder valve, having its seat at its lower end, upon suitable elastic packing, secured in a groove, as shown at a. E is a rod, having a screw thread on its upper end, by which the valve is operated. F is a sleeve nut engaged with the screw nut on the rod E, lifting and lowering said rod as the nut is turned one way or another. This nut is turned by a wrench or crank, or other suitable device, on the head G.

"The sleeve nut is screwed

## Opinion of the Court.

in the cap of the hydrant by a collar, and packing under the hollow cylinder stuffing box H, *as seen in the drawing*. J is a yoke, which is attached to the rod E by a set screw, and *which is secured* in the tube A, and prevented from turning, as it moves up and down, by projecting lugs, as *seen in Fig. 2*; and it will be *seen* that the arrangement is such that the rod and valve may be raised and lowered without being rotated. *This secures a uniform and perfect bearing of the valve on its seat, the packing a remaining undisturbed.*

“Provision is made for the discharge of the waste water by an orifice beneath the valve D, *marked f*, which orifice is opened and closed by a valve *marked g*, as *seen in the drawing*. *h* is a wing on the top of this valve.

“As the cylinder valve D descends the angular flange *i* on its inside *strikes* the wing *h* and raises the valve, as *seen in the drawing*, *thus allowing* any water which may remain in the hydrant to escape through the orifice *f* and aperture *k*. *It will be thus*

127 U. S. 566-567.

in the cap of the hydrant by a collar, and packing under the hollow cylinder stuffing box H. J is a yoke, which is attached to the rod E by a set screw *or its equivalent*, and *it is screwed* in the tube A, and prevented from turning, as it moves up and down, by projecting lugs, as *shown in detail at Fig. 2*. It will be *noticed* that the arrangement is such that the rod and valve may be raised and lowered without being rotated, *thus securing a uniform and perfect bearing of the valve on its seat, the packing a remaining undisturbed.*

“Provision is made for the discharge of the waste water by an orifice *f*, beneath the valve D, which orifice is opened and closed by a valve *g*. A wing *h* is provided upon the top of this valve.

“As the cylinder valve D descends, the angular flange *i*, on its inside, *striking* the wing *h*, raises the valve as *shown in the drawing*, and *allows* any water which may remain in the hydrant to escape *down* through the orifice *f* and aperture *K*, *thus pre-*

## Opinion of the Court.

*seen that no water will be left in the hydrant to freeze in cold weather.*

“The tube A is secured to the horizontal section B by a ring nut *m*, which contains recesses for packing rings around the valve, as *seen at n n*. Packing around the valve is secured by another ring nut *o*, and also under the end of the tube A, as *seen in the drawing*.

“P represents the discharge pipe, with a screw for the attachment of the hose, and a cap piece for covering the pipe when the hydrant is not in use

*venting any retention of water above the freezing level.*

“The tube A' is secured to the horizontal section B by a ring nut *m*, which contains recesses for packing rings around the valve, as *shown at n*. Packing about the valve is *also* secured by another ring nut *o*, and also under the end of the tube A, as *shown in the drawings*.

“P represents the discharge pipe, with a screw for the attachment of the hose, and a cap piece for covering the pipe when the hydrant is not in use.

*“It will be observed that the casing C loosely rests upon the main B, or upon a branch projecting upward from the same. This casing extends upward, enveloping the main portion of the water pipe A, at least that portion which is subterranean. Said casing extends upwards and fits loosely about the plug or hydrant at the portion A'. Above the upper terminus of the casing C is provided the bead a upon the hydrant proper. Sufficient space is left between the bead a and the upper terminus of the casing C to per-*



## Opinion of the Court.

"1. A hydrant or water plug, constructed substantially as shown and described,—that is to say, with the parts A and B connected together, as shown, and with a cylinder valve and a waste water valve connected and operated in combination substantially as herein specified.

"2. The arrangement of the parts A, B, valve D, case C, and stuffing box H, as herein described, for the purpose specified."

"1. In combination with a hydrant or fire-plug, a detached and surrounding casing C, said casing adapted to have an independent up-and-down motion sufficient to receive the entire movement imparted by the upheaval of the surrounding earth by freezing, without derangement or disturbance of the hydrant or plug proper, substantially as shown.

"2. In combination with a hydrant or fire-plug pipe A, the supply pipe B, and cylinder valve and waste valve, connected and operated substantially as herein shown and described.

"3. The combination of the hydrant or fire-plug pipe A, supply pipe B, valve D, casing C, and stuffing box H, substantially as and for the purpose shown."

The drawings of the original and of the reissue are also here placed side by side:

The material difference between the descriptive parts of the two specifications is that, in the reissue, it is stated that the casing C is movable, and that sufficient space is left between the bead *a*, upon the hydrant proper, and the upper terminus of the casing C, to permit of sufficient up-and-down play of the casing C to allow it to slide loosely up and down, to accommodate the upward and downward movement of the earth during the process of freezing and thawing, without



## Opinion of the Court.

any liability to derange the plug or hydrant. The casing could not thus slide loosely up and down, unless sufficient space were left between the bead *a* and the upper terminus of the casing. No suggestion of such arrangement is found in the specification of the original patent, and the drawing of that patent shows no space between the upper terminus of the casing and the bead or flange above it. This is new matter introduced into the specification of the reissue, contrary to the express inhibition of Section 4916 of the Revised Statutes.

Claim 1 of the reissue is for an invention not indicated or suggested in the original patent—namely, the independent up-and-down motion of the casing. In addition to this, the drawing of the original patent shows a close contact between the top of the casing and the bead or flange above it, so as absolutely to forbid any such independent up-and-down motion of the casing as is covered by the first claim of the reissue, while the drawing, Fig. 1, of the reissue, shows a sufficient space between the top of the casing and the bead or flange above it to admit of such independent up-and-down motion.

Issue having been joined, proofs were taken on both sides, and the Circuit Court entered a decree dismissing the bill, from which the plaintiffs have appealed. Its opinion accompanies the record, and is reported in 22 Fed. Rep. 292. It held that the reissued patent was invalid, as matter of law, upon a comparison of the original with the reissue. We concur in this view.

It is sought to sustain the validity of the reissue by attempting to show that the model filed in the Patent Office with the original application exhibited the invention covered by the 1st claim of the reissue. It is doubtful whether that fact is satisfactorily established. But, irrespective of this, the case falls directly within the recent decision of this Court in *Parker & Whipple Co. v. Yale Clock Co.* 123 U. S. 87 [17 Am. & Eng. 194]. It was held in that case that what was

127 U. S. 570-571.

## Opinion of the Court.

suggested in the original specification, drawings, or Patent Office model, is not to be considered as a part of the invention intended to have been covered by the original patent, unless it can be seen from a comparison of the two patents that the invention which the original patent was intended to cover, embraced the things thus suggested or indicated in the original specification, drawings, or Patent Office model, and unless the original specification indicated that those things were embraced in the invention intended to have been secured by the original patent. See, also, *Hoskin v. Fisher*, 125 U. S. 217 [17 Am. & Eng. 589]. In the present case, it cannot be seen, from a comparison of the two patents, that the original specification indicated that what is covered by the 1st claim of the reissue was intended to have been secured by the original.

In the present case, also, the reissue was not applied for until nearly eight years after the original patent was granted, and the reissue was taken with the manifest intention of covering, by an enlarged claim, structures which in the meantime had gone into extensive public use, and which were not covered by any claim of the original patent.

Infringement is alleged only of claims 1 and 3 of the reissue. As to the casing C of the 3d claim, it cannot, any more than the casing C of the 1st claim, be held to cover a casing which has the independent up-and-down motion referred to. Such casing must be construed to be the casing exhibited in the drawing annexed to the original patent—that is, one in which the up-and-down play is restricted by the overlapping bead or flange. On any other construction, claim 3 is an unlawful expansion, in regard to the casing, of what is found in the original patent. In addition to this, if the casing of claim 3 is only a casing which has no end play, it is anticipated by what is shown in letters patent, No. 19,206, granted to Race and Matthews, January 26, 1858, which patent was the subject of the decision of this

## Notes and citations.

Court in *Matthews v. Boston Machine Co.* 105 U. S. 54 [13 Am. & Eng. 501].

*The decree of the Circuit Court is affirmed.*

127 U. S. 572.

**Notes :**

## 1. "New Matter" in reissue :

Act 1832, Sec. 3 ; Act 1836, Sec. 13 ; Act 1837, Secs. 5 and 8 ; Act 1870, Sec. 53 ; **R. S. Sec. 4916.**

*Eureka Co. v. Bailey Co.*, 11 Wall. 488 [8 Am. & Eng. 280].

*Powder Co. v. Powder Works*, 98 U. S. 126 [12 Am. & Eng. 201].

*Ball v. Langles*, 102 U. S. 128 [12 Am. & Eng. 508].

*James v. Campbell*, 104 U. S. 356 [13 Am. & Eng. 341].

*Bantz v. Frantz*, 105 U. S. 160 [13 Am. & Eng. 542].

*Johnson v. Railroad Co.*, 105 U. S. 539 [14 Am. & Eng. 19].

*Gosling v. Roberts*, 106 U. S. 39 [14 Am. & Eng. 143].

*Moffitt v. Rogers*, 106 U. S. 423 [14 Am. & Eng. 244].

*Hoffheins v. Russell*, 107 U. S. 132 [14 Am. & Eng. 312].

*Gardner v. Herz*, 118 U. S. 180 [16 Am. & Eng. 368].

*Hartshorn v. Saginaw Barrel Co.*, 119 U. S. 664 [16 Am. & Eng. 530].

*Parker & Whipple v. Yale Clock Co.*, 123 U. S. 87 [17 Am. & Eng. 194].

---

## 2. The model as basis for reissue :

*Parker & Whipple v. Yale Clock Co.*, 123 U. S. 87 [17 Am. & Eng. 194].

*Hoskin v. Fisher*, 125 U. S. 217 [17 Am. & Eng. 589].

---

**Patent in suit :**

No. 75,344. T. R. Bailey, Jr., March 10, 1886. Hydrants. Reissue No. 6990. March 14, 1876.





# INDEX DIGEST

OF

## DECISIONS OF THE SUPREME COURT OF THE UNITED STATES IN PATENT CASES REPORTED IN THIS VOLUME.

---

	PAGE.
<b>Aggregation.</b>	
See Particular Patents, 1, 18.	
<b>Answer.</b>	
See Notice, 1.	
<b>Art.</b>	
1. An art and a process are the same thing under the patent law. Telephone Cases.....	1
2. A discoverer of a new art, process or method is entitled to a patent for the same, and for the means he has devised to make the discovery of actual value. Other inventors may compete with him for the ways of giving effect to the discovery, but the new art he has found will belong to him and those claiming under him during the life of his patent. Telephone Cases.....	1
3. A patent for the art (R. S. Sec. 4886) does not necessarily involve a patent for the particular means for doing it, and the mention of means in the specification is only necessary to show that the art can be used to advantage. Telephone Cases..	1
See Particular Patents, 4-8, 16, 20; Process, 1, 2.	

**Article of Manufacture.**

See Particular Patents, 17.

**Claim.***Double Claim.*

See Particular Patents, 4.

**Combination.**

See Particular Patents, 1.

**Construction of Statutes.**

R. S. 689. See Jurisdiction, 1.

R. S. 4886. See Art, 3.

R. S. 4887. See Term, 1

R. S. 4916. See Particular Patents, 22.

**Construction of State Statutes.**

See Evidence, 1.

**Corporation.**

See Evidence, 1.

**Defences.**

See Notice, 1.

**Description.**

See Process, 1.

**Evidence.**

1. Objection made to the sufficiency of the proof of the incorporation of the American Bell Telephone Company and of its title to the Bell patents; *held*, not well taken. Under the Act of the General Court of Massachusetts, Sec. 11, Chap. 224, the certificate of the Secretary of the Commonwealth is made conclusive evidence of the existence of a corporation. Telephone Cases..... 1

**Foreign Patent.**

See Particular Patents, 15; Term, 1.

**Infringement.**

See Particular Patents, 2, 3, 15.

**Invention.**

See Particular Patents, 1, 19, 21; Patentability, 1.

- PAGE-
- depressions, and the defendants' cylinder being smooth throughout, there was no infringement in this particular. *Hendy v. The Golden State and Miners' Iron Works*..... 588
3. Claim 1 of letters patent, No. 154,989, J. O. Joyce, September 15, 1874, *Lifting Jacks*, for "A pawl for lever-jack with two or more teeth, and adapted to move in inclined slots, grooves, or guides formed in the frame, substantially as described" limited in view of the specification to a pawl, moving by gravity alone in inclined slots, grooves or guides formed in the frame and *held*, not infringed by a pawl mounted upon an incline, with a spring to press the pawl down the incline, assisted by gravity, and having no slots, grooves or guides formed in the frame. *Joyce v. The Chillicothe Foundry and Machine Works Co* ..... 612
4. Claim 5 of letters patent, No. 174,465, granted to Alexander G. Bell, March 7, 1876, for *Improvements in Telegraphy*, for "The method of, and apparatus for, transmitting vocal or other sounds telegraphically, as herein described, by causing electrical undulations similar in form to the vibrations of the air accompanying the said vocal or other sounds, substantially as set forth," construed to be for the art and for the apparatus; *held*, that "articulate speech" was one of the "vocal or other sounds" referred to in the claim, though not mentioned by name in the patent. *Held*, to involve discovery in finding the art or process which consists in gradually changing the intensity of a continuous electrical current so as to make it correspond exactly to the changes in the density of the air caused by the sound of the voice, and invention in devising means to make it useful—devising a way in which these changes of density could be made and speech actually transmitted to put the art in a condition for practical use. *Telephone Cases*..... 8
5. This 5th claim is not in opposition to the decision in *O'Reilly v. Morse*, but is sustained by it, as this claim is not for the use of a current of electricity in its natural state as it comes from the battery, but for putting a continuous current in a closed circuit into a certain specific condition, suited to



PAGE-

- the transmission of vocal and other sounds, and using it in that condition for that purpose. It may be that electricity cannot be used at all for the transmission of speech except in the way Bell has discovered, and that therefore, practically, his patent gives him its exclusive use for that purpose; but that does not make his claim one for the use of electricity distinct from the particular process with which it is connected in his patent. Telephone Cases..... I
6. *Held*, that Bell's 5th claim is first for the process :  
 1st. The method of transmitting vocal or other sounds telegraphically as herein described, by causing electrical undulations similar in form to the vibrations of the air accompanying the said vocal or other sounds, substantially as set forth ; and second for the apparatus :  
 2d. The apparatus for transmitting vocal or other sounds telegraphically, as herein described, by causing electrical undulations substantially as set forth. Telephone Cases..... I
7. *Held*, that the Bell patent is not confined to a magneto-instrument and such modes of creating electrical undulations as could be produced by that form of apparatus. The words in the 5th claim—the "method herein described," "in the manner substantially as set forth"—include both the magneto method and the variable resistance method. The current must be kept closed to be used successfully ; but this does not necessarily imply that it must be so produced or so operated upon as to be incapable of being closed. There is nothing in the patent which requires it to be operated by instruments which are incapable of making the break. The patent is both for the magneto and variable resistance methods, and for the particular magneto apparatus which is described, or its equivalent. There is no patent for any variable resistance apparatus. Telephone Cases ..... I
8. The claim upon this broad construction is not "a claim for speech transmission by transmitting it— or, in other words, for all such doing of a thing as is provable by doing it." No one before Bell knew how to put electricity in a certain condition for successful use in speech transmission. Telephone Cases..... I

	PAGE.
9. Where it was not contended that Reis had ever succeeded in actually transmitting speech, but only that his instrument was capable of it, if he had known how; and it appeared that he did not know how, and that all his experiments in that direction were failures; that he discovered how to produce musical tones; but did no more, using an intermittent or make and break current, a different method; <i>held</i> , that it did not anticipate Bell's discovery. Telephone Cases . . . . .	I
10. Van der Weyde copied Reis, and it was not until after Bell's success that he found out how to use a Reis instrument so as to make it transmit speech. Telephone Cases . . . . .	I
11. McDonough was anticipated by Reis, and in his application for a patent made a circuit-breaker so adjusted as to break the connection by the vibrations of the membrane, one of the elements of his invention. Telephone Cases . . . . .	I
12. Varley's English Patents of June 2, 1868, and October 8, 1870, describe a Morse key, or something equivalent, and there is implied an operation on the principle of the electric telegraph, viz. : by making and breaking the circuit. The terms "undulations" and "waves" are used in his specification and in an entirely different sense from Bell, and are not anticipations. Telephone Cases . . . . .	I
13. Considering the history of Drawbaugh's inventions as described in evidence with perfected apparatus prior to Bell's invention, and the conduct of Drawbaugh after Bell's telephone had been patented and had become notorious, and the fact that Drawbaugh brought forward and patented other inventions after Bell's telephone had become universally talked about, and did not apply for a patent on his telephone until July, 1880, with other facts detailed at length, the Court comes to this conclusion, viz. : "We do not doubt that Drawbaugh may have conceived the idea that speech could be transmitted to a distance by means of electricity, and that he was experimenting upon that subject; but to hold that he had discovered the art of doing it before Bell did would be to construe testimony without regard to the ordinary laws that govern human conduct." Telephone Cases . . . . .	I

PAGE.

ward, for a bushing without any such notch, is an unwarrantable enlargement. *Cornell v. Weidner.* 549

**Patentability.**

1. Where patentee, when he applied for this patent (the telephone and apparatus) improvements in Telegraphy, and which was construed to be both for the art and for the apparatus, had never actually transmitted telegraphically spoken words, so that they could be distinctly heard and understood at the receiving end of his line; and the particular instrument which he had, and which he used in his experiments, did not, under the circumstances in which it was tried, reproduce the words spoken so that they could be clearly understood; but, proof was abundant and convincing that other instruments carefully constructed and made exactly in accordance with the specification, and without any addition whatever, had operated and would operate successfully; *held*, that it had attained the practical development necessary to make it patentable. *Telephone Cases*..... I

See Notice, 1; Process, 2.

**Principle.**

See Particular Patents, 5, 8.

**Process.**

1. The law does not require that a discoverer or inventor, in order to get a patent for a process, must have succeeded in bringing his art to the highest degree of perfection. It is enough if he describes his method with sufficient clearness and precision to enable those skilled in the matter to understand what the process is, and also if he points out some practical way of putting it in operation. *Telephone Cases* ..... I
2. After a patent has been granted for an article described or made in a certain way the inventor cannot afterward obtain a valid patent on an independent application for the method or process of making the article described in the earlier patent. *The Mosler Safe and Lock Co. v. Mosler, Bahmann & Co.* 560

See Art, 1, 2, 3; Particular Patents, 4-8, 16, 20.

**Product.**

See Process, 2.

**Reduction to Practice.**

See Patentability, 1.

**Reissue.**

1. The rule in *Parker & Whipple Co. v. Yale Clock Co.* (123 U. S., 87; 17 Am. & Eng. 194) affirmed that the Patent Office model alone is not to be considered the basis for a reissue in which a change of the invention of the original patent is sought. *Flower v. The City of Detroit*..... 621

See Particular Patents, 22, 23.

**Term.**

1. The effect of Sec. 4887 of the R. S. is not to render invalid an American patent by an English patent of an earlier date for the same invention, but only to limit its term. *Telephone Cases*..... 1

See Particular Patents, 15.

**Void Patents.**

See Particular Patents, 1, 17, 18, 19, 20, 21, 22, 23.

	PAGE.
<b>Novelty.</b>	
Particular mechanical patent <i>held</i> , not anticipated by a prior patented device capable of the same application, but not made with such intent .....	533
<b>Patentability.</b>	
Patentability of a principle.....	532
Process, patentability .....	531
Process, when not patentable .....	531
Reduction to practice necessary to patentability.....	532
Defence of want of patentability can be availed of without setting it up in answer.....	595
<b>Principle.</b>	
Patentability of a principle.....	532
<b>Process.</b>	
An art is a process.....	531
Process—patentability.....	531
Process—when not patentable.....	531
<b>Reduction to Practice.</b>	
Reduction to practice necessary to patentability .....	532
<b>Reissue.</b>	
“New Matter” in reissue.....	638
Reissue—The model as basis for reissue.....	638
<b>“Substantially as set forth.”</b>	
Effect on construction of claim .....	532

