

# CROSSBAR SWITCHING EQUIPMENT FOR THE AUSTRALIAN TELEPHONE NETWORK

E. R. BANKS, B.E.E., A.M.I.E.Aust.\*

Editorial Note: This article is reprinted from *The Journal of the Institution of Engineers, Australia*, Vol. 33, No. 4-5, April-May, 1961, with the kind permission of the Institution.

## INTRODUCTION

This paper is intended as a summary of an investigation carried out over the past three years into the type of switching system best suited to meet the requirement for economic and efficient expansion of the Australian Telephone Network. As a result of this work, a register-controlled crossbar switching system of L. M. Ericsson design was adopted as standard. Part I of the paper describes briefly the circumstances leading up to the investigation and the factors underlying the analysis and decision. Part II describes the system adopted and Part III indicates the way in which the equipment will be integrated into the network.

## PART I.—CHOICE OF A SYSTEM

### Local Network Problem

Since the first automatic exchange was installed in Geelong (Victoria) in 1912, the Post Office has progressively developed the automatic local networks using step-by-step equipment and employing the Strowger and, later, the British 2,000 type and SE.50 bimotional selectors. Step-by-step control is one of the earliest and most widespread methods of automatic switching and had its origin in the invention by Strowger of the 100-point selector (see Fig. 1). A group of these basic units can be used for a 100-line exchange. As the network develops succeeding stages are added for each digit required, and it is readily apparent that such a system is inflexible (see Fig. 2). The routing of a call is tied to the numbering, and a given block of numbers can be used only in a certain area. Development of a network of the

\*See page 154.

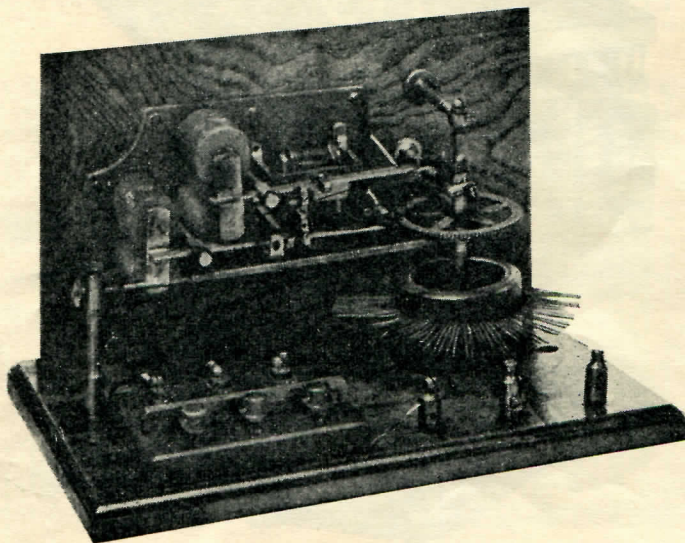

Fig. 1.—Original Strowger Switch, 1892.

type shown in Fig. 2 can proceed without serious difficulty until the numbering limitations of six-digit working, a practical capacity of about 500,000 subscribers, are approached. By 1956 the Melbourne and Sydney networks were nearing saturation on a six-digit number basis following the very rapid post-war development, and the cost of converting to seven-digit working, where required, was estimated at up to £6 extra per subscriber's line for the necessary additional switching stage.

The prospect of adding another switching stage also implied the upgrading of all links between existing switching stages in order to maintain the existing overall grade of service pro-

vided to subscribers. The grade of service or probability of call loss over the complete connection is, to a first approximation, the sum of the loss probabilities in each link and, therefore, the addition of an extra link would require extra circuit provision on all previous links. Finally, impulses are repeated forward in a step-by-step network from exchange to exchange. The consequent restrictions on signalling limits on both subscribers' and junction lines necessary to minimise impulse distortion and ensure successful operation of the switch at the distant exchange were proving a serious economic and technical limitation with the present equipment.

Considerable savings were seen to be possible by the removal of the basic restriction that routing and numbering are tied together. Use could be made of a given group of junctions for two traffic loads, one of which occurred during the day and the other at night, whereas at present, for example, the junction plant in the city areas is practically idle during the night, whilst the reverse is true in residential areas. A second result of divorcing routing from numbering would be that traffic could be moved between two exchanges on the most economic route rather than over a rigid backbone of links and switches. In many instances this would mean the bypassing of several intermediate switching stages and consequent plant savings. For example, in Fig. 2 the dotted route from the first selectors direct to the fourth selectors could carry traffic destined for any one of 1,000 subscribers, bypassing two switching stages.

A limited amount of direct routing had already been possible with step-by-step equipment but only within the main exchange group of the calling subscriber.

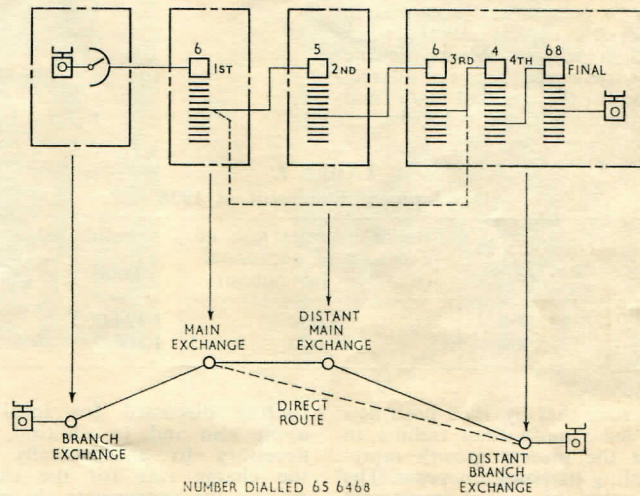

Fig. 2.—Call Routing in a Step-by-Step Network.

It was clear that the possibilities for effecting considerable economies existed if a flexible and universal system of direct routing could be introduced. Improvement in signalling methods would also remove signalling limitations on junctions and subscriber's lines.

These technical possibilities for economic expansion in the local networks can be seen to possess real potential in terms of possible capital savings when the rates of growth in the Melbourne and Sydney networks are considered. Table I shows the present size and expected growth of these networks.

**TABLE I.**  
**Development Statement at 1958**

Network	Numbers in use 1958	Present average rate of provision of additional numbers per annum	Estimated at 1980	
			Total	Rate of growth per annum
Sydney	332,000	25,000	1,124,000	79,000
Melbourne	273,000	20,000	1,100,000	77,000

It can be seen that by 1980 both networks will have more than trebled in size, in fact the present growth represents a doubling in every ten years. The major proportion of capital investment in the exchange and junction sections of a network is vested in the junctions, cable and conduits. The proportion at present is about 70 per cent. It is clear, therefore, that there is considerable scope for effecting economies in investment by adopting a switching system which will allow traffic to be carried over the shortest possible route to its destination.

**Trunk Network**

Since 1940, with the installation of semi-automatic transit trunk switching in Melbourne, the long distance trunk network has been developed using transit switching to eliminate the distant operator on long-distance calls. Fig. 3 shows a simple schematic of the routing for a trunk call from Melbourne to Sydney. The Melbourne trunk operator can dial direct to the subscriber in the Sydney network without the assistance of the Sydney telephonist. This mode of operation has been introduced at capital cities and provincial centres throughout the Commonwealth in the past 20 years. However, the growth of trunk traffic and the increasing cost of manual operation, together with the development of techniques in recent years to provide economically large blocks of long-distance channels by coaxial cable or radio, now make it feasible and necessary to consider the extension of subscriber control into the long-distance network. For subscriber-dialling of trunk traffic, Australia-wide numbering and charging schemes are necessary in order to simplify directory presentation and switching system design and operation. The study and development of a plan aimed at developing the Australian network for ultimate subscriber-dialling of all calls was commenced in 1956. This study soon highlighted the limitations of the present switching equipment in meeting this objective economically. In the Trunk Network the requirements for

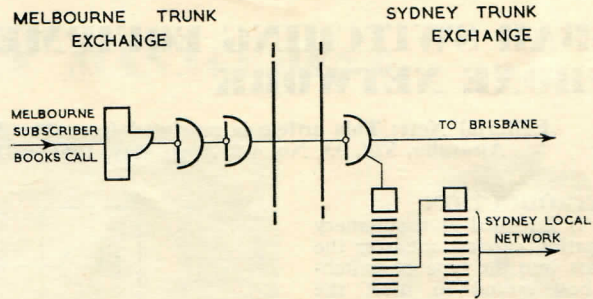

Fig. 3.—Trunk Connection, Melbourne to Sydney.

tion on the subscriber's meter. The national number will be the local number plus between one and three national digits, and this eight-digit number must be received and interpreted by the switching equipment. For long built-up connections a high quality circuit must be assured, especially once the operator is removed altogether and is not available to reject the occasional noisy or low-volume connection, as she may do at present.

**Rural Networks**

The third problem facing the Post Office was the economic extension of continuous automatic service to rural

routing discussed for local networks apply also and, in addition, it will be necessary to automatically determine the charge rate for the call and to register the appropriate charge informa-

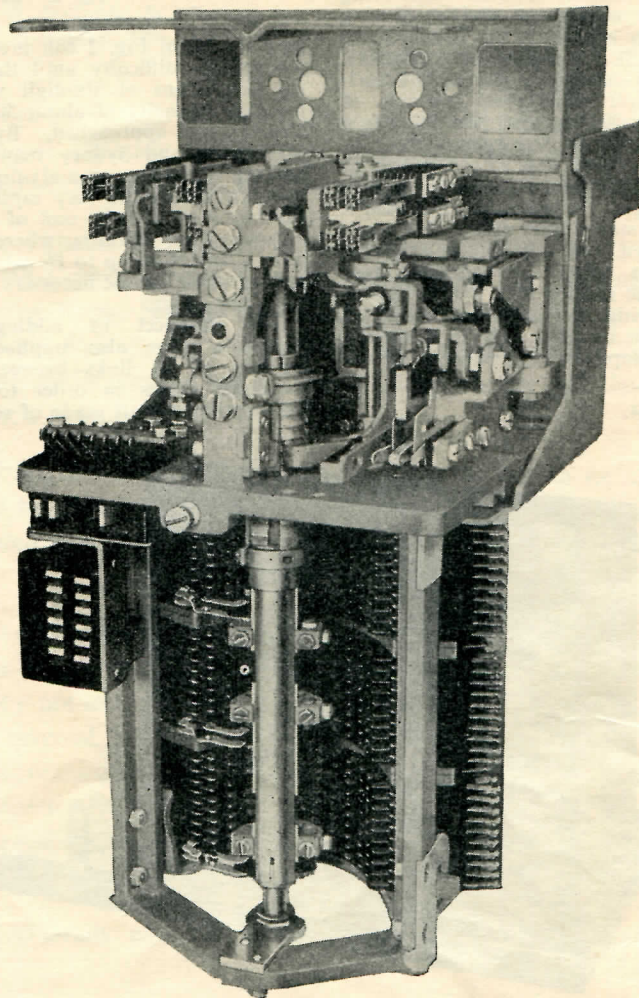

Fig. 4.—Bimotional Selector.

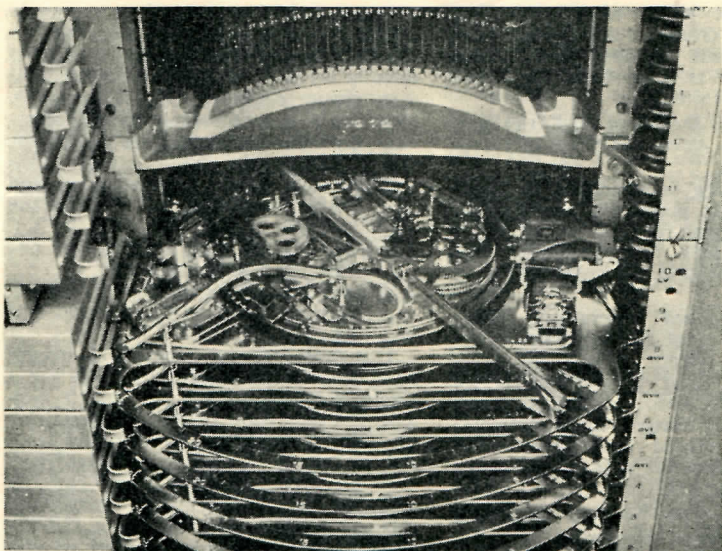

Fig. 5.—500-Line Selector.

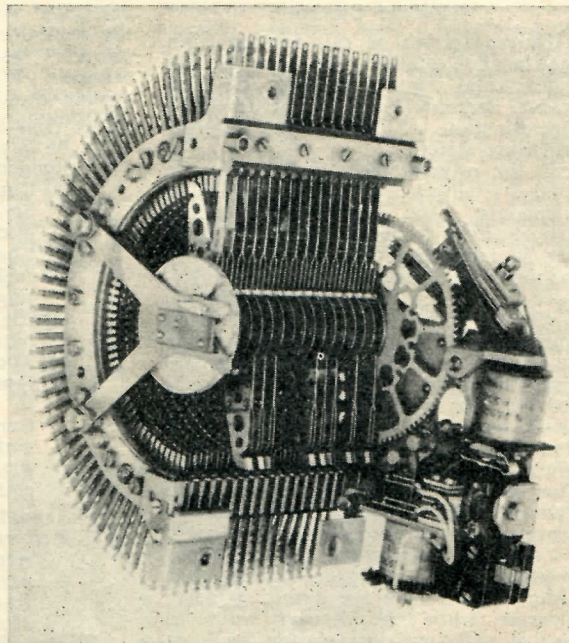

Fig. 6.—Motor Uniselector.

subscribers. The installation of the Rural Automatic Exchange (R.A.X.) in the post-war period went a long way towards eliminating the small manual exchanges of 200 lines or less. However, these units provided automatic access only between subscribers on the exchange in question, and the majority of these exchanges had as a parent the local provincial exchange, which was manual. With the proposal to introduce a national numbering plan and extended dialling, and to remove manual working, it became apparent that the present R.A.X., due to its design and trunking, could not be integrated readily in the closed-numbering areas proposed for these districts. Furthermore, the outstanding problem in the rural areas was the medium-size provincial town with an exchange of 200-1,000 lines for which Magneto or Common Battery (C.B.) manual equipment was being employed. Here, as in the trunk exchanges, the costs of operation and telephonists' facilities were rising to the level where it was economic to consider automatizing

the system. In these areas subscriber distance-dialling and automatic multi-metering were essential, and the step-by-step automatic switching equipment currently used in the large cities was not capable of providing for the economic introduction of such a scheme.

These three sectors of the network, local, trunk and rural, were therefore all in need of a new switching system which would facilitate economic expansion and provide for the ultimate complete automatization of the system. To meet this requirement, a detailed examination of the various available switching systems was undertaken with a view to selecting the one most suited for the immediate and long-term Australian requirements.

**Switching System Types**

It is necessary at this stage to pause and review very briefly the main types

of electromechanical switching systems which have been employed in telephone exchanges in the past 50 years.

Switching systems consist essentially of two elements, the switches or speech path connecting devices, and the controls. These controls are either concentrated in common units taken into use only to set the switches, or small control elements are permanently associated with each switch. The latter principle is usually termed step-by-step operation since the successive switches each take one digit and route the call one stage further.

These systems can be classified in four main categories identified by the type of switch employed:—

- (i) The Bimotional Selector (Fig. 4), developed from the original Strowger patent, is used extensively in step-by-step switching systems and in the director system which employs a common translating register.
- (ii) The 500-point Planar Switch (Fig. 5) is used in a register-controlled common-drive system on the rotate and thrust principle.
- (iii) The Motor Uniselector (Fig. 6), developed by Siemens & Halske later by Siemens Bros., England (now A.E.I., Woolwich), has 16 arcs and 52 contacts per arc, providing a maximum of 200 four-wire outlets. This switch has been used in step-by-step and register-controlled systems, and may employ common drive as in the Rotary Systems used extensively in Belgium and France.
- (iv) The Crossbar Switch (Fig. 7), developed from the patents of Betulander in 1896, has been used in both step-by-step and register systems, and has received increasing attention in recent years.

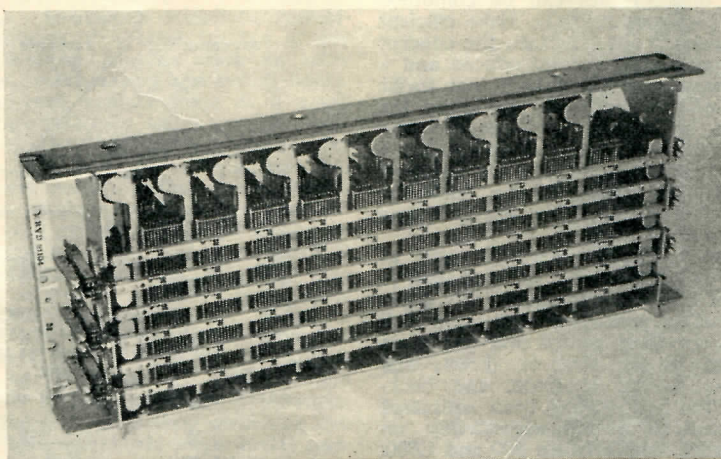

Fig. 7.—Crossbar Switch.

**Register Control**

The separation of call routing from the number dialled was seen as the fundamental requirement of the new system, and could only be achieved by the adoption of a register-controlled switching system.

In the original manual exchange the control intelligence was embodied in the telephonist. She identified the calling line, received from the caller the number he required, connected the call by the most direct available route and registered on a docket the appropriate charge. With the introduction of step-by-step working, the operator's intelligence was in effect distributed throughout the system. Each switch performed a small part of the routing function, and the meter associated with the subscriber's line switch registered the unit call charge when the called subscriber answered. The common control or register type exchange collects this control intelligence once more into a centralised unit.

Common controls require high-speed operation and high-speed signalling in order to overcome the necessary delay incurred while the register waits to receive sufficient information to start work. The development of reliable and fast-operating controls, providing rapid call connection and, at the same time, competing economically with the simpler step-by-step system, originated in the immediate pre-war era and, receiving considerable impetus from the technological developments of the 1939-45 period, have expanded rapidly since the war.

The London Director system is an example of register control applied to bimotional selectors. The required number is examined in the register and a routing code is pulsed into the step-by-step switching system. This code will vary depending on where in the network the caller originates his call. The problem here is that this routing code is pulsed out of the register at 10 c.p.s., the normal dialling speed, and delays after dialling of up to 20 seconds may result before the connection is established and ring is fed to both subscribers. Further, the "director", as the register is called cannot vary the route taken by the call to take advantage of changes in circuit loading with time. The programme is rigid, and routing is still tied to the numbering allotted to the routing code. The planar 500-point system is also slow, due primarily to the speed of setting of the large switch. The two electromechanical switching principles suitable for register control which have received the greatest attention in recent years have been the Crossbar and the Motor Uniselectors.

**System Comparison**

Systems using these two techniques were closely compared during the study, and the crossbar principle chosen. Concurrently, the various crossbar systems were examined, and as a result, the register-controlled crossbar system employing linked trunking and developed by L. M. Ericsson, Sweden, was finally selected as the type of switching system best able to meet the A.P.O. requirements for the next 10-15 years. These

decisions were taken after examining the available crossbar and motor unselector systems against five basic criteria. It was considered that the system chosen should:—

- (i) **Meet the Required Facilities and be in an Advanced Stage of Development:**
  - (a) Routing independent of numbering, economic and flexible alternate routing.
  - (b) Charging determination and registration for national dialling.
  - (c) High-speed operation, minimum post-dialling delays.
  - (d) The system should be developed and proved in service in the local, rural and trunk transit sectors of a network, and should have interworked successfully with step-by-step equipment.
- (ii) **Comply with Modern Technical Performance Standards:**
  - (a) Signalling and Transmission performance should take maximum advantage of the latest developments in these fields.
- (iii) **Be Suitable for Economic Local Manufacture.**
- (iv) **Be Economic to Install and Maintain.**
- (v) **Be Adaptable to Future Developments and, in particular, Electronics.**

These points will now be discussed and the two systems compared. In all comparisons reference is confined to systems in which the switches are used efficiently.

**Facilities and Stage of Development**

**Alternate Routing:** Both systems are available with register control and, therefore, routing can be made independent of numbering. As discussed above, the desirable situation is to be able to select for a given call the most direct route to the required destination. It can also be shown that the most economic arrangement of junctions in a network is one in which only the base load of traffic is carried on the direct circuits, the peaks being routed on the backbone route via the tandem exchange. In this way, overflows of traffic from several direct routes can be combined on the backbone route to make efficient use of the circuits. In fact, the concept of marginal utility is introduced and a specification developed such that traffic is carried on the direct route by the addition of circuits until the cost per unit of traffic (Erlang) of carrying the traffic direct is equal to the cost of carrying the traffic on the backbone route. Fig. 8 illustrates this principle of alternate routing.

Studies in large networks, such as Sydney and Melbourne, indicate that, to take the fullest advantage of this alternate routing principle, any given call may require to be routed over one of up to four choices, that is, direct, first alternate, second alternate, and backbone. Further, it has been estimated that the total circuit accessibility required may vary between 500 and 1,000, depending on the size of the exchange. To ensure efficient operation in an

alternate routed network, it is necessary that a choice be made of a suitable free circuit from all the possible available circuits on each of the four routes with a minimum of delay. To achieve this objective at a switching stage with minimum post-dialling delay, the equipment should be capable of:—

- (i) having prior knowledge of the traffic conditions on each of the possible routes;
- (ii) selecting at high speed a free circuit on a suitable route;
- (iii) positioning or setting the switch at high speed on the selected outlet.

The most efficient method of storing prior knowledge of circuits is to use a single common equipment which controls the operation of a single switching stage which has access to all routes from the exchange. Crossbar switches meet this requirement since they can be arranged in "link-trunked" arrays to provide any desired availability, and the two or three stage array can be set and controlled by a single marker unit. This concept of link-trunking will be further discussed below. However, motor uniselectors have a limited availability of 200 from a given switching stage and, to obtain larger availabilities, a further stage must be added. Attempts to control two stages of motor uniselectors simultaneously have proved complex and uneconomic, and have been abandoned in favour of sequential stage-by-stage setting. This stage-by-stage control means that, after an indication has been received, each switch must be set in turn, whereas the crossbar selectors can be operated simultaneously in about 40 milliseconds compared with about 360 milliseconds for the motor switches.

Testing of circuits in the crossbar system is electrical and is carried out by the marker. There is therefore no limitation to the number of circuits over which the hunt may be carried out. With the motor unselector, however, the switch hunts at 200 steps per second. Therefore, to test a group of 50 trunks some 250 milliseconds are required compared with some 70 milliseconds for the crossbar scan.

Summing up, the crossbar switch is capable of providing single switching

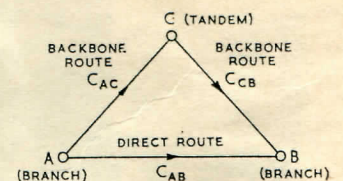

$C_{AB}, C_{AC}, C_{CB}$  COST OF CIRCUITS ON THESE ROUTES.

$N_{AB}^N$  TRAFFIC CARRIED ON  $N^{TH}$  CIRCUIT ON DIRECT ROUTE.

$E_{ACB}$ , ADDITIONAL TRAFFIC WHICH MAY BE OFFERED TO ROUTE  $ACB$  WHEN AN EXTRA CIRCUIT IS ADDED, TO PRESERVE THE SAME GRADE OF SERVICE ON THE ROUTE.

CIRCUITS ARE ADDED TO ROUTE  $AE$  UNTIL

$$\frac{C_{AB}}{N_{AB}^N} \geq \frac{C_{AC} + C_{CB}}{E_{ACB}}$$

Fig. 8.—Principle of Alternate Routing.

stages of any desired availability under a single control, is faster in testing for free circuits and faster in establishing the final connection.

**Charging:** Charge determination and registration is possible with both systems, and depends primarily on the design of the register equipment.

**Stage of Development:** One of the primary considerations in selecting the particular crossbar system to be adopted was the extent to which it had been engineered and proved in service. When a new switching principle is devised and a new exchange system is developed, the first step is the construction and testing of a laboratory model or, more often, a private automatic exchange (P.A.X.) to be used in the factory of the developing manufacturer. The model having been successfully proved, the equipment is then ready for application to public networks. This next step may take up to 10 years, during which time the manufacturer and his customers must invest considerable engineering and design effort in the adaptation of the prototype exchange to the three sectors of a communications network, local, rural and trunk, and the solution of all the various interworking problems which will arise when any new plant is grafted on to existing equipment.

The objective in this study was to choose a system which would require the minimum redesign and adaptation in order to take maximum advantage of technology overseas and conserve our own limited resources for the not inconsiderable task of carrying out the inevitable interworking redesign which would be necessary. A switching system is a developed entity ready and tried for application to all three fields, whereas an exchange principle is the nucleus of the system. Of the available crossbar types the one chosen appeared on the evidence available, and, in the opinion of the author and other Post Office engineers who had visited overseas administrations and manufacturers, to be the most thoroughly developed and tested system available.

**Technical Standards**

One of the vital considerations was that the switching system chosen should possess a low psophometric noise characteristic. A built-up telephone connection consists of a large number of dry metal-to-metal contacts such as relay springs, switch wipers and switch banks. Across each contact there is a small potential difference which, under conditions of vibration, may generate a noise e.m.f. The problem is to ensure that the total noise on the circuit, which consists of the sum of the contributions from each contact, is kept to an acceptable level to ensure a good standard of transmission. This has important economic as well as aesthetic aspects since the speed at which information can be passed and comprehended is related to the signal-to-noise ratio of the channel.

In an endeavour to reduce circuit noise in nation-wide dialling networks, manufacturers of modern switching systems have introduced noble metal pressure contacts for the speech path connections. The quality of these contacts

is of particular importance in Australia, due to the "ribbon" nature of our main line network and the large number of transit switching points which may be in tandem on a trunk call. Crossbar switches, due to the relay-like nature of their operation, used pressure contacts, and the contact material is a noble metal. The German E.M.D. motor uniselector was redesigned to use pressure contacts of noble metal in the speech path but the British motor uniselector still employs base metal high-pressure wiping contacts (see Fig. 6).

The present equipment, using base metal rubbing contacts, has a relatively poor noise performance by modern standards, and regular bank cleaning is necessary to minimise noise interference.

Noble metal pressure contacts used on crossbar switches, have a resistance of a fraction of an ohm compared with resistances of 1 to 4 ohms after one million operations in the case of base metal rubbing contacts.

The method of signalling in a register network takes a different form from that in a step-by-step direct impulsing network. The routing information is passed between registers using high-speed coded voice frequency signals at a speed of 10 digits per second. This removes the restrictions on network development formerly imposed by the necessity to repeat impulses forward stage by stage. Only the line or supervisory signalling remains associated with the particular junctions. Thus, the resistance limits

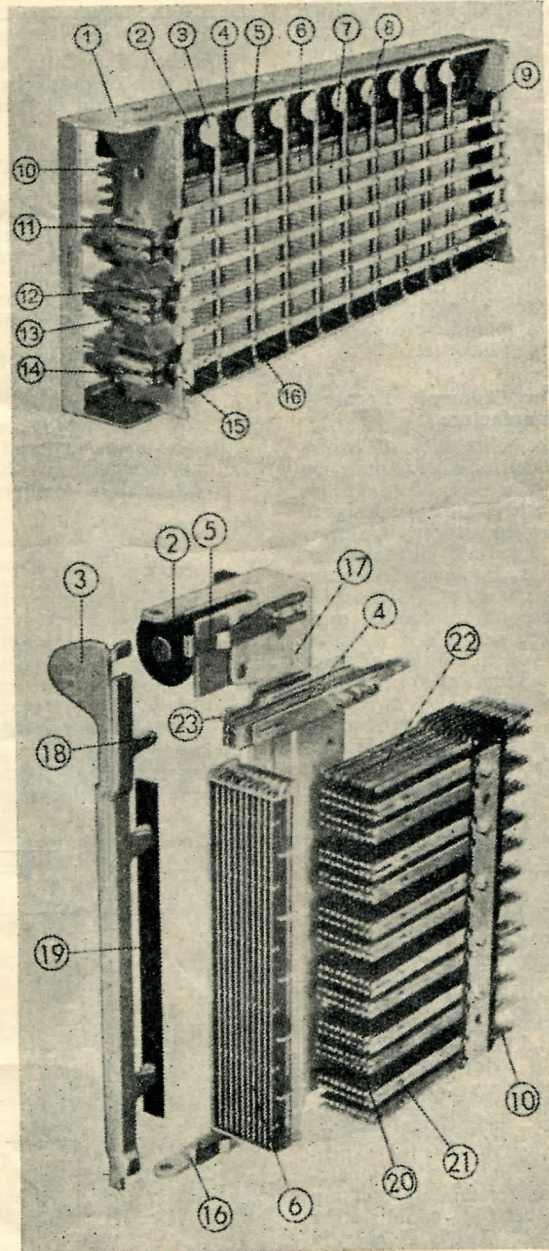

Fig. 9.—Crossbar Switch—Elements.

for junctions are governed only by the sensitivity of the pick-up and answer signal relays, and the use of sensitive reed relays for these functions will virtually remove the signalling limitation to junction resistance. Since with Registers the subscribers' dialled impulses are received and stored at the local branch exchange and do not require retransmission, the tolerance to impulse distortion can be increased considerably. The present dial-speed requirement of 9-11 i.p.s. can be relaxed to 7-22 i.p.s., thus considerably reducing, if not eliminating, dial maintenance and allowing a significant increase in subscribers' line resistance. The present resistance limit of 1,000 ohms is expected to increase to about 1,800 ohms which, as in the case of the junction limit, will permit an appreciable increase in the present transmission standard. These two relaxations in resistance limit will allow significant savings to be effected in our future external plant investment which, as mentioned above, comprises 70 per cent. of the local network investment.

The preceding discussion has centred on the technical facilities which must be met by the switching equipment. Of equal importance in a telecommunications network is that the equipment may be economic to purchase, install and maintain. In addition, in the Australian network it is important to ensure that to a maximum extent possible the equipment standardised should be capable of economic local manufacture.

**Suitability for Economic Local Manufacture**

In assessing the suitability of equipment for manufacture, two factors were considered important:—

- (i) The equipment must be so designed that it can be produced simply and advantage can be taken of the latest developments in manufacturing techniques.
- (ii) The shop cost of production must be as low as possible.

Any telephone system consists of three main elements: racking and frameworks, relays, and switches. The two first elements are a common production problem no matter which system is considered and, in fact, the two Australian telephone equipment manufacturers have been producing relays and racking for the Department since the Second World War. However, by adopting crossbar there was a chance to simplify considerably the switch production problems. The crossbar switch consists essentially of a rectangular array of relays and springsets. The complete switch consists of a series of similar sub-assemblies (see Fig. 9) and at no stage are critical adjustments required during manufacture or assembly. The simple production and assembly requirements of the switch lend themselves to automatic methods. In contrast, the motor unselector, which is a high-speed rotating mechanism, requires the use of expensive assembly jigs. Many of the operations involve close tolerancing and are of such a nature that they could not be readily automatised. Table II gives a brief comparison of the manufacturing requirements of the two switch types.

**TABLE II.**  
**Comparison of Switch Production Requirements**

Date	10/20 Crossbar switches	200 Outlet motor unselector
No. of piece parts	49 of which 13 are used in relays	135
Processes	Mostly presstools and stamping operations	Presstools and stampings for the banks, wipers and frame. Machine tools for the motor and gears.
Assembly	Rectangular non-critical assemblies	Careful jiggings and concentricity and bank alignment tests
Testing	Simple relay operations with no close tolerances	Close tolerances with critical speed requirements

The second essential consideration is that the cost of production of the switching system should be a minimum. It is possible to assess the likely relative costs of production of two switching systems when the following factors are realised:—

- (i) The labour cost represents 75 to 80 per cent of the total costs for all types of electromechanical switching systems.
- (ii) The number of control relays in a switching system does not vary significantly, from between 5 and 6 relays per line. This is independent of the type of control and applies equally to common control and step-by-step exchanges.
- (iii) The main material component in an exchange is the speech path connection equipment or the

crosspoints which, in assemblies, comprise the switches.

It follows from the above considerations that the exchange with the smallest amount of material in it will be the cheapest to produce and, further, the exchange using the fewest crosspoints or speech connections to achieve the required standard of service will possess the least material.

A study of this question of minimum crosspoint requirements shows that the number of crosspoints per subscriber's line can be made a minimum using crossbar switches in link-trunked arrangements. This is evident from the following simple example. Consider an exchange requiring 100 inlets and 100 outlets, and no congestion. There are three possible ways of achieving this result. Fig. 10 (a) shows the simplest

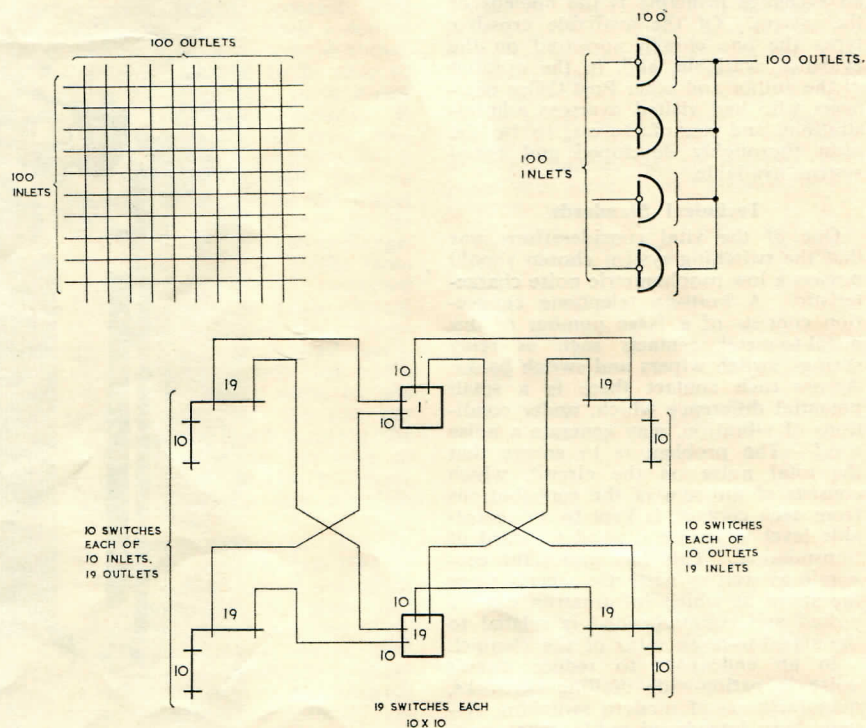

**Fig. 10.—Trunking Principles.**

arrangement, a single crossbar switch possessing 100 inlets and 100 outlets or 10,000 crosspoints. Fig. 10 (b) shows the same exchange using 100 outlet motor uniselectors or bimotional switches. 100 such switches are required utilising a total of 10,000 crosspoints. Both the above examples are cases of direct trunking, in which the free outlet from the switch is seized without first ensuring that at the next switching stage the associated inlet will itself have access to a free outlet. Fig. 10 (c) shows a link-trunked arrangement of crossbar switches so arranged as to provide the complete access with no congestion but using 5,700 crosspoints. In this switching stage the inlet is not connected to a link from the first switch until a complete path through the three switches has been tested and reserved for the connection. Crossbar switches may be arranged in linked arrays of two or three stages similar to that shown to provide any required availability. Clos showed that in this way an exchange could be trunked using the minimum possible number of crosspoints and that, from cases similar to the no-congestion example quoted above, exchanges having fixed standards of congestion can be derived. Finally, Clos demonstrated that a 10/20 crossbar switch is close to the ideal practical size for economic link-trunked arrays. Table II shows the relative number of crosspoints and relays per line for comparable exchanges using various switches for speech path provision.

electromechanical switching plant, due mainly to the simple relay-like nature of the switch and, hence, the elimination of mechanical adjustments and the need for lubrication of moving parts. The only adjustments remaining are those associated with relays. A major problem is designing bimotional and motor uniselector switching systems is the integration of the relay circuitry with the operating tolerances of the mechanisms and motors, respectively. The result has always been a large proportion of marginal relays subject to close timing tolerances in the circuitry of these systems. With crossbar, the circuitry consists of simple logical blocks utilising for the most part "donkey" type relays.

Surveys of relative maintenance effort for various systems have been conducted in all countries, and Table IV is a summary of the general findings.

TABLE IV.

Equipment type	Staff per 1000 lines
Crossbar	0.1-0.3
British motor switch	0.4-0.5
German motor switch SE.50 and 2000 type	0.5
Bimotional switches	1.0-1.4

**Future Developments**

It is now possible to construct fully-electronic telephone exchanges, but the

present rate of component development indicates that such exchanges are unlikely to be economic for some 10-15 years. However, it is clear at this stage that any exchange equipment purchased must be suitable for adaptation to electronic switching plant.

The main advantage of electronic control equipment is its speed of operation compared with relays. Therefore, to benefit from electronics, the switching medium must be capable of fast operation and overall simultaneous control from a single common equipment.

**Conclusion**

Taking all the above arguments together it becomes clear that the most desirable switching system for use in the Australian network is a link-trunked crossbar system, which has been fully developed and tried in service for local, rural and trunk transit applications, and has worked successfully with step-by-step networks. Of the systems on offer, the L. M. Ericsson crossbar equipment was chosen as most nearly fulfilling these requirements. This system, which uses 10/20 crossbar switches and link trunking, has been developed and proved in service in all applications and with a variety of other types of plant including step-by-step equipment. The next part of this paper will survey the origins of Crossbar Switching Equipment and describe briefly the system adopted for Australia.

**PART II.—THE CROSSBAR SYSTEM**

The crossbar switch was one of the earliest developments in automatic telephony. Betulander, a Swedish engineer, worked with the crossbar principle of switching in the early part of the century and, as a result, in 1912 he took out a patent for the first crossbar switch. The diagram in the patent application is shown in Fig. 11.

At the same time, development was in progress in the United States of America

TABLE III.

Exchange type	Crosspoints/line	Relays/line (approx.)
10/20 Link-trunked crossbar	20.0	6.0
22/52 Link-trunked crossbar	29.0	6.0
100 Outlet motor uniselector	65.0	6.0
200 Outlet motor uniselector	84.0	6.0

It can be seen, therefore, that the most suitable system from a manufacturing viewpoint would be a crossbar system with a 10/20 switch used in link-trunked arrangements.

**Economic Installation and Maintenance**

It follows from the above arguments that the system containing the least material should be the easiest to install. This, in practice, is proving to be the case. The three crossbar exchanges so far installed in Australia have each averaged between 5-7 hours/line for the exchange equipment compared with an equipment installation time of about 15 hours/line inclusive for a bimotional exchange. Bearing in mind that the three crossbar exchanges installed have been "first in" installations, the installation time could be expected to reduce further as familiarity with the equipment is gained.

An important cost in a telecommunications network is the maintenance charge for the exchange equipment. Crossbar equipment has the most favourable maintenance performance of any

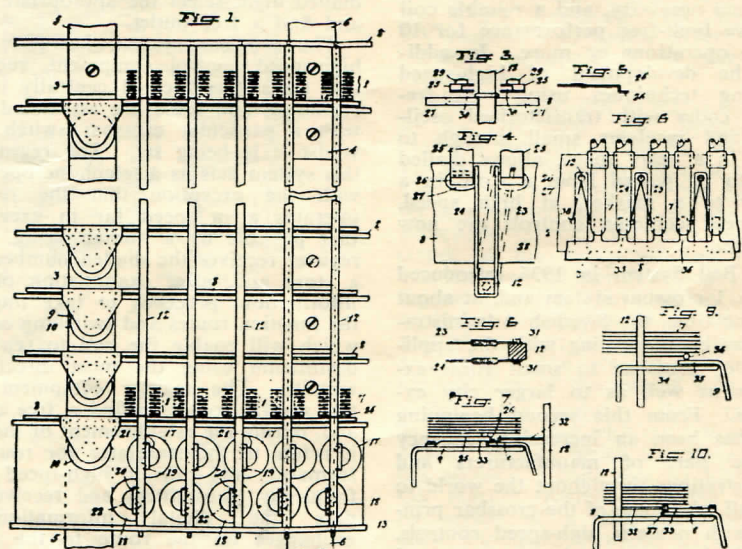

Fig. 11.—The Betulander Crossbar Patent.

along similar lines. In May, 1913, Reynolds of the Western Electric Company patented a selector with relay contacts actuated by a system of crossing bars which produced a direct and instantaneous connection between a series of contacts. The Reynolds switch did not arouse great interest, due primarily to the large capital investment required for its development and manufacture. The selector was rather complicated and possibly too expensive to manufacture with the facilities available at that time. However, Betulander's crossbar principle was used to produce a relay switching system and the Relay Automatic Telephone Company acquired this system and installed several all-relay exchanges in the 1914-1920 period. However, these crossbar switches and the relay system were at this time too expensive when compared with the Strowger system based on a switch first patented in 1891 by Almon Strowger of Kansas City, and referred to at the beginning of this paper (see Fig. 1).

The main reason that these crossbar switches proved too expensive in exchanges at this time was that the common controls, on which a crossbar exchange relies, were not sufficiently fast in operation or reliable in service. Relay design and manufacture was in the early stages and single contacts were still used with little, if any, spark quenching. The wide operating tolerances, relatively slow speed of operation and the use of separate impulsing relays for each selector, were simplifying the conditions which resulted in the extensive use of the Strowger switch for early telephone exchanges.

It was not until about 1936 that technical developments in the field of relay manufacture enabled the designers to introduce an economic crossbar switching system. This development of the relay and other switching components has accelerated since the Second World War until today a relay with twin contacts of special alloy, copper-silver or palladium-silver, with adequate quenching where necessary, and a reliable coil will give fault-free performance for 10 million operations or more. In addition, the development of high-speed signalling techniques using voice-frequency codes with transistorised oscillators and receivers small enough to mount in a relay space, allows dialled digits to be passed from a store in a register to a marker, at high speed. High-speed common controls are now available.

The Bell System in 1936 introduced the No. 1 crossbar system and, at about the same time, the Swedish Administration was experimenting with the application of crossbar to small rural exchanges as well as to larger city exchanges. From this second beginning there has been an increasing tendency on the part of manufacturers and administrations throughout the world to take full advantage of the crossbar principle with modern high-speed controls. Table V demonstrates the recent general trend towards crossbar type switching by some leading manufacturers.

TABLE V

Manufacturer	Crossbar system	Previous systems
A.T.E. Liverpool, England	5004 5005A/B (Under development)	Strowger, 2000 type, SE.50 Siemens' motor uniselector (step-by-step)
Bell Telephone Manu- facturing Co., Belgium	8B Crossbar and Penta- conta	8A, Crossbar 7 series Rotary Systems (Register controlled)
C.G.C.T. and L.M.T., France	Pentaconta crossbar	R6 and Standard Rotary Systems (register con- trolled)
L. M. Ericsson, Sweden	ARF 102 ARF (Swedish PTT) ARM 20/50 ARK 50 (In production)	ARF 101, ARF 50/51 ARF 30/50 Crossbar 5000 line system XY System (register controlled)
Mix & Genest, Germany	H.K.S. crossbar	Strowger and German motor uniselector
U.S.S.R.	Unnamed crossbar	500-line system and pos- sibly Strowger
Siemens & Halske, Germany	ESK relay crossbar (Under development)	Strowger E.M.D. (step- by-step and register con- trolled)
Western Electric, U.S.A.	Bell Nos. 4A and 5 (In production for Bell Co. only)	Bell Crossbar System 1, 1A, 2, 2A and 4. Panel- Rotary, 100-outlet Strow- ger (register controlled)

#### A Comparison: Crossbar with Step-by-Step

As mentioned in Part I, the basic element in our present switching system is the bimotional selector. This switch steps vertically under the control of impulses received by the vertical magnet and then searches horizontally for a free outlet on the particular route associated with the level chosen. Thus, each switch receives one of the dialled digits and directs the call one step further towards its destination. Each switch has associated with it sufficient control equipment to recognise the dialled digit, select the appropriate level and find a free outlet.

The crossbar system, however, uses high-speed control equipment, registers and translators located centrally in the exchange, and these are associated only with a particular crossbar switch only whilst it is being set. The register in this system acts as a telephone operator, with the exception that the register operates at a speed far in excess of that possible by a human being. The register receives the dialled number into a store and, after examination of this information, proceeds to take into use the junction routes and switching centres which will enable the call to reach its destination using the most direct free circuits. The register equipment may test several routes to find a free circuit and, during the establishment of the call, it refers to the translator for route information and calls in high-speed voice frequency transmitters and receivers to pass the digital information to exchanges on the route to the called number. Having established the call, the register releases and is available to set another connection.

The application of the principle of common register control is possible only because of the high operating speed of the crossbar switch and the associated techniques of multi-voice-frequency high-speed signalling and high-speed register translator operator. A system of this type enables efficient use to be made of the existing switching and line plant. Register operation provides opportunities to take maximum advantage of flexibility in the use of junctions in the network and in the allocation of numbers to subscribers. With the Australian step-by-step system the junction routes used for a particular call are determined by the digits dialled, whereas, with the register crossbar system using suitable translations, the most direct free route can be used, and this may vary depending on the amount of traffic flowing in the network and its direction at any time of day. Thus, the junctions in the city business centre, which with the step-by-step system lie idle at night, may be used for residential traffic when register-controlled crossbar is introduced. With our step-by-step system, blocks of subscribers' numbers are allocated on a regional basis and, since subscribers' development is not uniform over the network, there is a shortage of subscribers' numbers in some areas whilst other areas have numbers to spare. With register crossbar equipment the allocation of numbers to subscribers in particular areas is far more flexible and number saturation in one area can be readily relieved.

#### The Crossbar Switch

The crossbar switch or selector, as the name implies, consists of a series of vertical bars or bridges and another series of horizontal bars. Fig. 7 shows



a range of crossbar switches of various sizes.

These switches differ from the bimotional selector since they are not capable of setting up a connection without the assistance of an external control circuit. This control circuit receives the dialled digits and decides which inlet must be connected to a given outlet and then operates the corresponding horizontal or vertical magnets to close the relay contacts at the required intersection. Fig. 9 shows a crossbar switch of the type used by the A.P.O., and an enlarged and exploded picture of a typical bridge or vertical inlet.

The switch in Fig. 9 has 10 inlets or 10 vertical bridges, and 20 outlets, which are derived from the horizontal bars. Each bar will operate either to the top magnet or the bottom magnet associated with it thus lifting the selector fingers up or down. From five bars, therefore, 10 outlets are derived and the sixth bar operates as a wiper switching element in association with the other five to provide a total of 20 outlets.

Fig. 12 shows in detail the method of operation of the vertical and horizontal magnets to close a connection. To operate springset No. 6 in Fig. 12 the selecting magnet 6 tilts the selecting bar so that the selecting finger moves upwards over the flanges of the actuating spring and comes to rest against the projecting stop. Attached to the armature of the holding magnet is a vertical holding bar which normally moves into the recess of the actuating spring and, hence, does not operate the spring pile. However, when a selecting finger is moved from its normal horizontal position by the operation of the selecting bar,

the outer extremity of the finger bridges the recess in the actuating spring so that, when the holding bar is operated, it comes into contact with the operated selecting finger and operates the appropriate springset. The selecting finger is held between the holding bar and the actuating spring by the pressure exerted by the holding magnet. Since the selecting finger is flexible, the horizontal bar can restore to normal and be used to assist in the setting of another call level and the first connection under the control of the holding magnet.

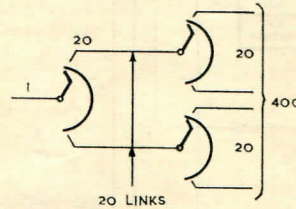

Fig. 13.—Link Trunking in Crossbar.

**The Crossbar Switch as a Selector**

Each vertical of the crossbar switch can be considered as a 20-outlet selector. Thus, a 10/20 crossbar switch consists of 10, 20-outlet selectors. Twenty outlets are not sufficient from a given selector stage to provide efficient trunking, and, in fact, this limitation to the number of outlets available is one of the disadvantages of bimotional switches. Crossbar switches can be arranged to provide for any number of inlets and outlets by a method known as link trunking. An illustration of this principle is given in Fig. 13, which shows how access is gained to 400 outlets

from a given inlet using two ranks of selectors.

This principle of developing a selector stage from two partial stages of crossbar switches is used throughout the ARF exchange system, the type normally used in large city networks. The connections between the first and second partial stages are known as links, and the marker controlling the complete stage selects not only a free outlet but also a free link to connect the inlet to the required outlet. Hence, both partial stages are set simultaneously. Using this method of trunking, selector stages with any desired number of inlets and outlets can be constructed.

**Typical Crossbar City Exchange**

The operation of a typical crossbar city branch exchange (ARF) is described below, with reference to the schematic diagram (Fig. 14).

Subscribers are trunked through two linefinder stages, SLA and SLB, in groups of 200 to the S.R. relay set. From this relay set access is gained through register access equipment to the local registers. The S.R. relay set provides transmitter battery feed and supervision for the calling subscriber. The group selector stage consists of two partial stages of crossbar switches arranged in units, each unit providing 80 inlets and 400 outlets. From this group selector stage, direct access is gained to the SLC and SLD stages of the subscriber's linefinder, final selector group. As well as these direct routes to 1000-line groups, a backbone route connects the group selector stage to the incoming group selector (GIV) and this route carries traffic not handled on the direct routes to the SL stage. The full SL stage provides access to 1000 subscribers. The SL stage is under the control of the SL marker (SLM) whilst the group selector or GV stage is controlled by the GV marker (CBM). Incoming calls from other exchanges pick-up Register I which controls the setting of the call through the GIV and SL stages. Outgoing calls from the GV stage may be routed either to other crossbar exchanges or to step-by-step exchanges.

When a subscriber removes his handset his line relay "LR" operates and indicates the call to the SL marker of the 1000-line group to which he belongs. The SL marker selects a free SR relay set and register and connects the calling subscriber through the SLA and SLB stages to this relay set and register. The marker is then released and the register transmits dial tone to the subscriber. The subscriber dials the wanted number, into the register. For a local call the register now controls the selection of the wanted subscriber.

First, the register seizes the GV marker associated with the GV or group selector unit to which the SR relay set has access. A code receiver KM in the GV marker receives from the register, by means of a high-speed signalling code, the digits required to select the correct outlet from the group selector stage. The GV marker connects the call through the required outlet on the SL

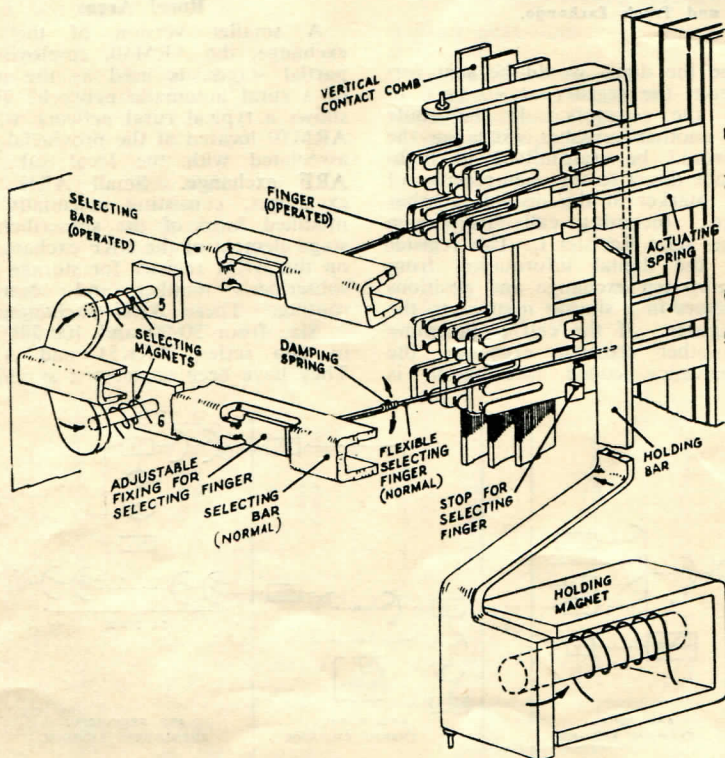

Fig. 12.—Operation Detail of Crossbar Switch.

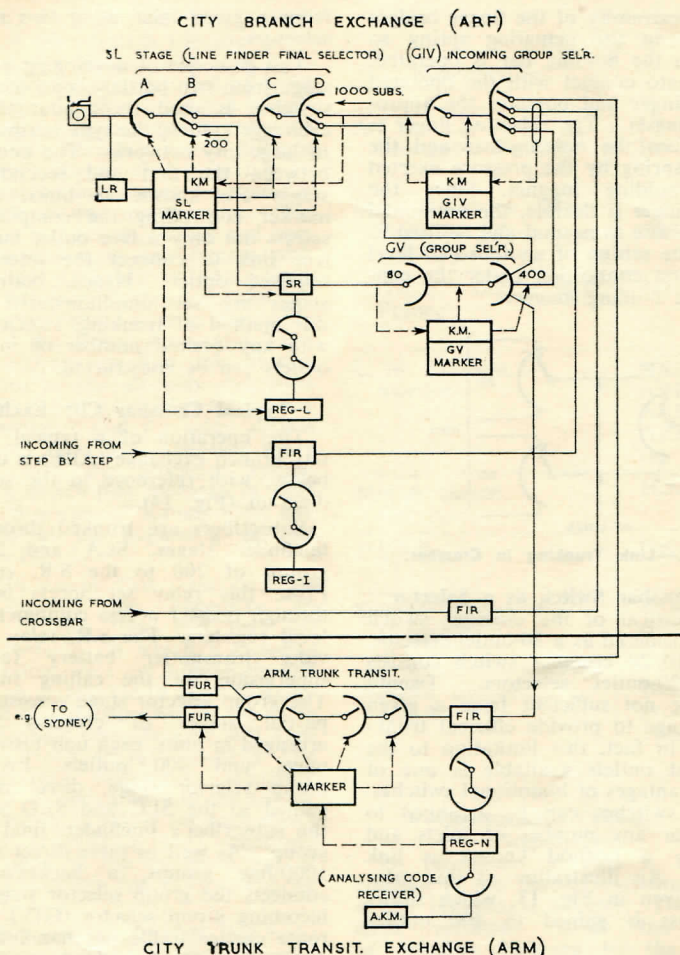

Fig. 14.—Crossbar City Branch Exchange and Trunk Exchange.

stage, and the SL marker is then seized. The GV marker releases as soon as it has completed the group selector connection. If there are no free outlets on the direct route to the 1000-line group required, the GV marker tests the route to the GIV stage, selects a free outlet and connects the call as before. The SL marker now calls for the three digits required to locate the subscriber in the particular 1000-line group already selected. These digits are also sent forward, using high-speed code, and are received by the receiver in the SL marker. The SL marker positions the four SL stages for the wanted subscriber and, having notified the register of the condition of the called subscriber, releases. The complete connection is held from the SR relay set which now transmits ringing current to the called subscriber and ring tone to the calling subscriber. At this stage, SR takes over control of the call, and the register releases. From this stage on, the supervision of the call under the control of the SR relay set is similar to the supervision in our present step-by-step exchanges.

For an outgoing call the GV marker selects the required outgoing route and identifies what type of signalling is required for the digits to be sent forward. For a route to a step-by-step

exchange the digits would be sent forward from the register at 10 i.p.s. to position the selectors. If the route was to another crossbar exchange the digits would be transmitted in high-speed code direct to the code receiver of the GV marker at the distant crossbar exchange. Incoming calls from step exchanges seize Register I. This register receives the digital information from the step-by-step exchange and positions the selectors in a similar manner to the local register. If the call is incoming from another crossbar exchange, the multi-frequency coded information is

taken into the code receiver (KM) of the GIV marker direct, and the call is completed in a similar manner to a local call.

**Trunk Exchange**

If the subscriber requires to call a destination outside the local network, for example a Melbourne subscriber calling Sydney, on receipt of the code for Sydney, "02", the Register L initiates action to connect the subscriber to a network register, Register N, at the trunk exchange. The trunk exchange equipment (coded ARM) consists of a selector stage built, according to requirements, of either two or four partial stages of switches, and controlled by common markers, registers and analysing code receivers. These trunk exchanges can be expanded in units of 200 lines up to a total capacity of 4000 trunks in and out.

The Register L proceeds to transfer the digital information into the Register N at high speed, and Register N assumes control of the call. The analysing code receiver (AKM) is called in to determine the charge rate to be applied, and when the called subscriber answers the receipt of the answer signal in the FIR-U causes meter pulses to be applied to the line at the rate appropriate to the call distance and charge. The routing of the call is controlled through the necessary transit switching stages by Register N. At each transit point the local code receiver calls for sufficient digits to enable the most direct free circuit to be taken into use as the next link in the connection. Having completed the selection in the transit exchange, the transit marker releases and the Register N talks direct to the next transit code receiver in the call.

**Rural Areas**

A smaller version of the ARM exchange, the ARM50, employing two partial stages, is used as the nucleus of a rural automatic network. Fig. 15 shows a typical rural network with the ARM50 located at the provincial centre associated with the local subscribers' ARF exchange. Small ARK (rural) exchanges, consisting essentially of a modified form of the subscribers' line stage element of the ARF exchange, rely on the ARM register for storage of the subscriber's number and control of routing. These ARK exchanges vary in size from 30-90 and 100-2000 lines in two series, ARK51 and ARK52. They have been engineered as unit type

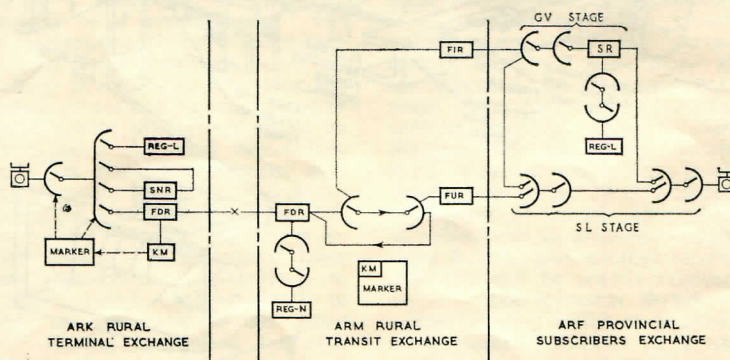

Fig. 15.—Crossbar Rural Network.

equipments in cabinets, and, as such, can be readily installed and moved when required. In spite of careful planning, it is often found that in areas where these exchanges are required initially, unforeseeable expansion occurs and the telephone facilities may need to be replaced by city branch exchange type equipment.

When the subscriber lifts his handset

a junction is seized to the ARM exchange and dial tone returned from the register. The dialled digits are stored in Register N and, if the call is outgoing, the connection is established through the ARM exchange and on to the destination. However, for a local call the register returns instructions at high speed to the marker in the ARK exchange and the call is established on a local link,

the junction being released. If all junctions are busy or out of service due to fault or calamity, the call is intercepted by an emergency local register in the ARK which will complete local calls only.

**Signalling**

In telephony, signalling is the general term applied to the process of establishing, supervising and, when necessary, disconnecting a connection between two subscribers. There are two broad categories of signals, termed information and line signals. The information signals are the digits the caller dials to specify the party to whom he wishes to be connected. The line signals are those signals necessary to seize a junction to guard it against intrusion until the call is clear, to signal when the called party answers so that the call may be charged and to clear the connection after the conversation.

With a register-controlled system the information is stored in the register and passed to other registers or code receivers as required. The information signalling system is separate from the line signalling system, the former being associated with the registers and code receivers whilst the latter is associated directly and permanently with the junction or trunk line.

In the present step-by-step network the various trains of impulses from the subscriber's dial are used as they arrive, to position the selectors in the connection, each impulse train extending the call one step further towards its destination. By this means, the call is extended to the distant subscriber as soon as the last impulse train has left the caller's dial and positioned the final selector. Ring is fed to the called subscriber almost immediately and the caller receives ring tone.

With a register system, however, the wanted number is fed into the register and the system does not start selecting a route until three or four digits have been received. This is an advantage since the more information possessed before routing commences, the more intelligent can be the routing decision or, in other words the cheaper can be the route chosen. However, since delay has occurred, the switching and signalling system must switch and signal faster than the subscriber candial in an attempt to make up the lost time. The information used at the various stages for routing the call consists of the digits the subscriber has dialled. The digital information is held in the originating register and transferred as required to subsequent registers and code receivers using a high-speed coded system of signals. The code to be adopted for Australia is designed for error checking, each digit being represented by two frequencies, and receipt of any other number of frequencies is recognised as a false signal. The chance of speech imitation or crosstalk being recognised as a signal is thus virtually eliminated. These frequencies must be so located in the speech band that they do not interfere with the frequencies used for line or supervisory signals. Fig. 16 shows the channel frequency spectrum and the information signalling. Table VI sets

**TABLE VI.**  
Allocation of Frequencies and Codes for Forward and Backward Signals between Registers.

		Forward Signals									
Digit		1	2	3	4	5	6	7	8	9	0
1380	0	X	X		X			X			
1500	1	X		X		X			X		
1620	2		X	X			X			X	
1740	4				X	X	X				X
1860	7							X	X	X	X
1980	10	Used with above for 5 special signals									

Backward Signals  
Frequencies: 1140, 1020, 780, 660

**A SERIES**

- 1 Send next digit
- 2 Restart
- 3 End of Selection  
(Transition to B signals)
- 4 5 digits) MFC terminal
- 5 6 " " ) Transition to
- 6 7 " " ) 2A signals
- 7 5 digits)
- 8 6 " " ) SxS terminal
- 9 7 " " ) Transition to
- 10 Number)  
length ) 3A signals  
unknown

**B SERIES**

- 1 Idle sub.
- 2 Busy sub.
- 3 No throuout.
- 4 Congestion
- 5 Idle sub., non-metering
- 6 Interception service and malicious call

**2A SERIES**

**Call to Crossbar Subscribers**

- 1 Send next digit
- 2 Restart
- 3 End of Selection  
(Transition to B signals)
- 4 Send 1st digit decadic
- 5 " 2nd " "
- 6 " 3rd " "
- 6 " 3rd " "
- 7 Waiting place, Next digit
- 8 " " , Restart
- 9 " " , Same digit
- 10 " " , Previous digit

**3A SERIES**

**Call to Step-by-Step Subscribers**

- 1 Send next digit
- 2 Restart
- 3 End of Selection  
(Transition to B signals)
- 4 Send Previous Digit
- 5 Send 1st digit decadic
- 6 " 2nd " "
- 7 " 3rd " "
- 8 " 4th " "
- 9 " 5th " "
- 10 " 6th " "

Congestion is always given as A3 (or 2A 3, 3A3) + 1B4.  
Waiting place signal is only given once in a call. If the signals 7-10 are received once more by the register, they are interpreted as 3A7-10.

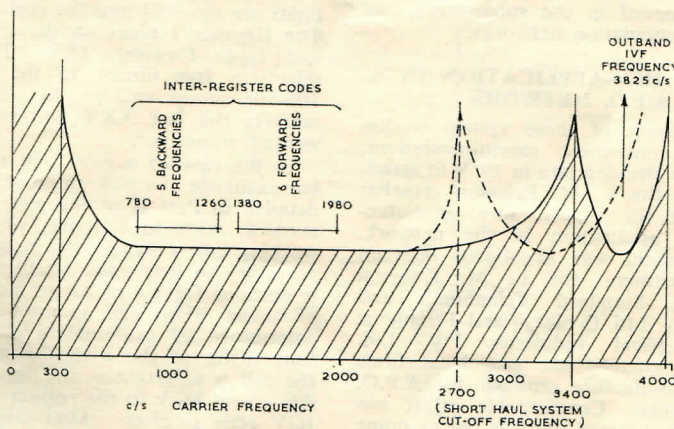

**Fig. 16.—Signalling Frequencies.**

out the codes for forward and backward signalling between registers.

The backward or reverse signals are used to call forward the next digit required by the code receiver, A, 2A and 3A series, to indicate the class of the called subscriber's line to the outgoing exchange, 1B series, so that busy or ring tone can be fed to the calling subscriber, and to indicate to the controlling register whether the call is to a crossbar or a step-by-step subscriber, A series. This last type of signal is necessary for two reasons:—

- (i) If the call is to the step-by-step network, routing must be commenced as soon as possible because subsequent digits must be pulsed into the step-by-step network at 10 i.p.s. and full advantage cannot be taken of the fast signalling code. In the case of a call to a crossbar subscriber, the routing and switching may be sufficiently fast on a particular route (say a direct route) to cause a "waiting place" signal to be used. In this case the route is not seized until all digits have arrived in the store. If the route were seized earlier than this, the common code receiver equipment would be held for an inordinately long time waiting on the dialled digits from the subscriber.
- (ii) For calls to crossbar destinations the register releases after an end-of-selection signal has been received from the distant code receiver to signify that routing is complete. However, in the case of step-by-step destined calls, no such end-of-selection signal is possible and, consequently, the register must release after it is satisfied that all digits required have been sent on. Therefore, a number length signal is transmitted to the register to indicate the number of digits required for the particular code dialled. Unfortunately, in our networks numbers of all lengths from 3 to 7 digits are in use spread randomly through the number range. Where the number length cannot be determined from the first four digits of the code dialled, the "don't know" signal is used and the register releases a short period after clearing its store. Finally, the register is also designed to release four seconds after it has cleared its store if no further digits arrive.

A description of the use of these backward signals is given in the section dealing with application in metropolitan networks.

The line signalling systems required in a crossbar network are required to perform only the supervision of the links between exchanges. The code of signals used is given below:—

<i>Forward</i>	<i>Reserve</i>
Seizure	Answer
Clear Forward	Clear Back
	Release Guard
	Blocking
	Meter pulses (when required on end links)

These signals can be achieved using D.C. loop signalling, utilising the two con-

ditions, loop and open circuit. On derived circuits, a single voice-frequency can be employed using a pulse length code, 50 milliseconds pulse for seizure, 150 milliseconds pulse for answer, and so on. An alternative recently introduced is the utilisation of a channel just above the speech channel but below the carrier frequency, to carry a single frequency signal. The frequencies commonly used are 3825 or 3850 c.p.s. The advantage of this system is that the signals are isolated from the speech channel and, in consequence, simple loop and open-circuit conditions can be simulated. In addition, meter pulses can be sent back during conversation without interfering with speech.

Reference was made earlier to the Compelled Sequence method of signal transmission. This method is preferred for both outband line signalling and for inter-register signalling. The scheme is one in which the forward signal is sent until an acknowledgment is received at the outgoing end. This acknowledgment cuts off the forward signal and the break in turn cuts off the acknowledging signal. Further, the acknowledgment signal in the inter-register case is used to indicate to the originating register the next signal required. This compelled sequence method is proof against most transient interruptions likely to occur on open-wire routes and transmission systems, and, due to the one-at-a-time flexibility of the procedure, only the information required at each centre is sent forward.

The simplified requirements imposed on the line-signalling equipment have resulted in an increase being possible in the allowable D.C. resistance limit of junction cables. The previous restriction imposed by the requirement to minimise impulse distortion has been removed in a crossbar network and the limiting condition is the ability of the receiver relay in the outgoing repeater to hold over the answer reversal. The allowable limit has been increased from 1,200 to nearly 4,000 ohms. Similarly, with register control, the pulses from the subscriber's dial only require to be identified by the register store receiving relays. The subscriber's line resistance can consequently be increased from 1,000 to 1,800 ohms. Both these relaxations will allow considerable savings to be achieved in the subscriber's and junction reticulation networks.

### PART III.—APPLICATION IN A.P.O. NETWORK

As a result of these system studies and the consequent recommendations, the A.P.O. decided late in 1959 to standardise on the L. M. Ericsson crossbar equipment for supply, local manufacture and application in the network. An agreement was negotiated between the Department, the L. M. Ericsson Company, Standard Telephones and Cables Pty. Ltd. (Sydney) and Telephone and Electrical Industries Pty. Ltd. (Sydney) whereby the two local firms would manufacture crossbar for A.P.O. requirements. Considerable effort has since been directed towards the planning and programming for the initial supplies

of equipment, both purchased direct from Sweden and manufactured locally, to ensure that the initial inter-working problems have been allowed for and to enable smooth introduction of the initial deliveries to commence in the 1961-62 financial year. The following sections indicate briefly the way in which the equipment will be integrated into the network.

#### Metropolitan Networks

There are three broad categories into which the initial crossbar installations can be grouped in city networks. New exchanges naturally will be installed exclusively with crossbar equipment, and examples of these currently on order from L. M. Ericsson are: Haymarket, 1961-62, 8,000 lines, a central city exchange in the Sydney network; Flinders, central city exchange in the Adelaide network, 1961-62, 5,400 lines; Cooma, a provincial centre exchange, 2,000 lines. Already installed and cutover in September, 1960, is Toowoomba (Queensland), 6,300 lines, a provincial local exchange which, together with two small exchanges, Sefton (N.S.W.) and Templestowe (Victoria), represent the present working crossbar equipment in the network.

In the second category are the crossbar extensions to existing step-by-step branch exchanges. To allow extension of these exchanges with crossbar, it is planned in each case to close them off when the current 1,000-line unit is fully allotted and, using one digit of the six-digit exchange code, open up a seven-digit 10,000-line crossbar section. The block schematic trunking for such an exchange is shown in Fig. 17.

The six-digit step-by-step exchange in this example has 10,000 numbers with code 53, and level 1 has been expanded to seven digits to provide a fresh 10,000-line group with code 531, XXXX, leaving 9,000 numbers on the step-by-step exchange with codes 53,2-0,XXX. Consider the original step-by-step calls. The unselector connects the subscriber to a 1st selector in the main exchange (see Fig. 2), and a call for 53,XXX arrives via the 1st and 2nd selectors to the 3rd selector. If the call is destined for the step-by-step exchange, it continues to the final selector. If the code is 531 an interworking register is seized from level 1 of the 3rd selector and the remaining digits are received into the register store. The Register I picks up the GIV stage and feeds forward "IX". The GIV selects a free circuit to the required 100-line group and the SL stage then receives the last XXX and selects the wanted subscriber.

In the case of a call from the crossbar exchange, the pick-up procedure is as detailed in Part II of the paper. However, as mentioned above, when interworking into a step-by-step network it is necessary to determine whether the call is destined for a crossbar or step-by-step exchange. This can, in most cases, be determined by examination of the first four digits of the dialled number. If the call is to crossbar, the signal A5 or A6 is sent back to the register from the IGV code receiver. After this, all signals passed back are in the 2B series

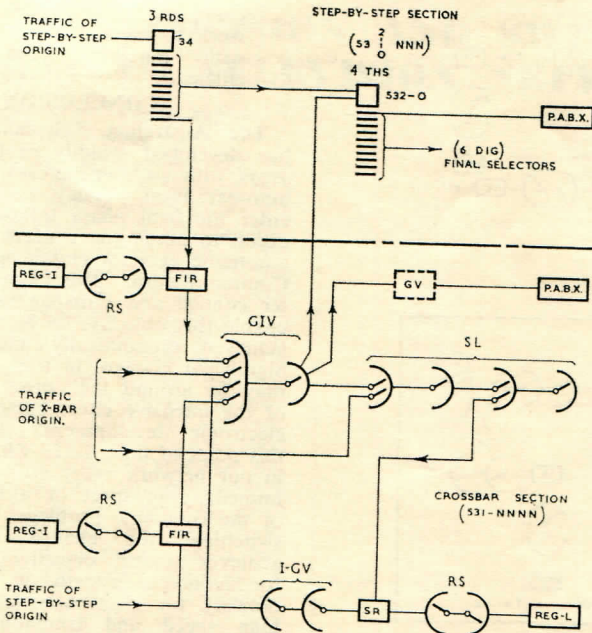

Fig. 17.—Extension of 6-Digit Step Exchange with 7-Digit Crossbar.

which has been designed for controlling a call through the step-by-step and crossbar network to a crossbar destination. Signals 2A, 5, and 7 are designed to allow for the case when the call is routed through a step-by-step switching stage. In this case the maximum flexibility is achieved if all digits are pulsed out decimally and another Register I is seized when the crossbar network is re-entered. For calls to step-by-step equipment, one of signals A7-10 is returned and the subsequent signal from the 3A series indicates from what digit the register must start when pulsing out into the network.

Incoming calls from the crossbar network arrive on the GIV and may be destined either for the crossbar or step exchanges. The first digit received will be the 3rd, and, if 1, the code receiver will call for the first X and route to the required 1,000-line group. If the digit

is 2-0 the GIV will select a route to the appropriate rank of 4th selectors and send a reverting signal to the Register L to send the 4th and subsequent digits decimal.

The third application of crossbar equipment will be the introduction of the first selector stage and register, which are in effect the essential elements of the crossbar switching system, into step-by-step exchanges instead of or to replace D.S.R.s. (discriminating selector repeaters.) This requirement arises in one of two ways. Either on extension the D.S.R.s. or their earlier equivalent the S.S.R.s. (switching selector repeaters) are replaced, or a trombone trunked exchange is converted to a group selector branch by the introduction of a crossbar 1st group selector stage. A typical trunking diagram, showing the replacement of the D.S.R. with a crossbar group selector stage, is shown in Fig. 18. The D.S.R.

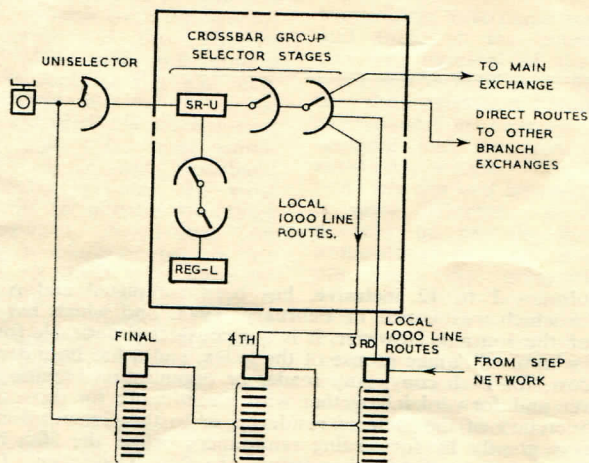

Fig. 18.—Crossbar First Selector Stage in Step Exchange.

is used in some step-by-step branch exchanges to provide direct routes to other exchanges in the same main exchange area, that is, possessing the same first code digit. All other calls are routed via the main exchange first selectors. The crossbar GV stage places no limit on the code groups to which direct routes can be established and, thus, a large portion of the traffic load can be removed from the main exchange route. In addition, a direct route can be established from the GV stage to the trunk switching equipment to handle trunk traffic. This is not possible on the trunk code "O" using the present 2,000 type D.S.R.

**Rural Networks**

In the rural networks, the first requirement will be to minimize purchase of further R.A.X. equipment which cannot be readily integrated in the national numbering and switching scheme. For this reason, the initial bulk orders of equipment will contain a proportion of ARK country terminal exchange equipment. These small units, ranging in size from 30-2,000 lines, will cover a very large proportion of the requirements in country areas for automatic equipment, to take the place of the R.A.X. and the medium-sized manual exchanges. Where the exchange will grow beyond 1,500 lines in the 20-year period, or the proportion of local traffic is high, an ARF exchange would be considered, especially where the rate of growth is high.

The introduction of ARM transit equipment in country areas is also being planned to provide a core for the ARK exchange networks and to facilitate distance dialling.

**Trunk Network**

The present operator-controlled step-by-step trunk network is of basically different character from the step-by-step local networks for two reasons:—

- (i) The number is open, or, in other words, the digits dialled by the operator to reach a certain location vary, depending on the location of the operator and the route she chooses to take. For example, a Perth operator calling Sydney via Adelaide may dial 80351, whereas an operator at Adelaide dials only 351. In the national numbering scheme subscribers or operators would always dial 02 for Sydney, no matter where in the Commonwealth they were and how they reached their destination.
- (ii) The present method of signalling on long distance carrier telephone channels using 2VF has been designed especially for operator dialling, and the system would not be entirely suitable for use on a subscriber-dialled system with high-speed circuit seizure.

For these reasons, it is generally considered that the objective should be to retain this network as an entity and to build up in parallel a subscriber-dialled long-distance network linking progressively the local networks. The present network would continue to handle the traffic not catered for by subscriber-dialling facilities or to assist the subscribers requiring a telephonist to complete the call. The operators would

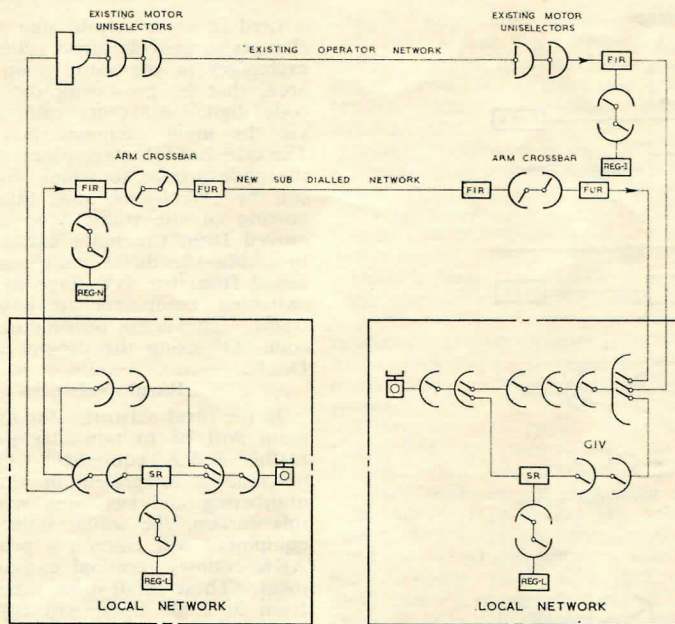

Fig. 19.—Development of Trunk Network with Crossbar.

have access into the subscriber network as shown in Fig. 19.

The first large-scale problem to be solved in the trunk network will be the provision for subscriber dialling out of the large capital city networks. This is becoming necessary in both Sydney and Melbourne, and will become important elsewhere to avoid further costly extensions to the manual trunk exchanges in these centres. To achieve S.T.D. from the large city networks, several additions and modifications to existing plant are necessary:

- (i) The installation of a main ARM trunk transit exchange in the centre concerned. This installation would provide analysis for charge determination, routing and access-barring of subscribers who did not want their telephones used for long-distance dialled traffic.
- (ii) The modification of existing meters

in many exchanges to allow for multimetering.

- (iii) The modification of repeater equipment to pass meter information back to the branch exchange from the central ARM transit.

Work is proceeding with the objective of solving the problem of meeting all three requirements. The resulting trunk transit exchanges will be the present-day equivalent of the 1940 Melbourne Trunk Exchange and the keystone on which the nation-wide S.T.D. network can be developed. This network will develop to fulfil two primary objectives:

- (i) The progressive automatization of the whole Australian network, and the consequent provision of a high-grade continuous automatic telephone service.
- (ii) The steady reduction in manual operating, and consequent high

costs, and the expansion of the network to meet demands for service with maximum economy and efficiency.

### CONCLUSION

The Australian Telephone Network has developed steadily in the past 50 years with an ever-increasing degree of automatization. Today, we are about to enter the final phase following the decision to adopt the concept of a single automatic network embracing the whole Commonwealth. The adoption of register control and crossbar switching will enable this objective to be progressively achieved economically and efficiently. Significant changes in the telephone art may be around the corner as a result of the intensive effort being invested in electronic development. However, at this point of time, faced with a doubling in our network every 10 years, and no immediate prospect of a firm solution of the economic problems of electronic switching, the change contemplated achieves several objectives. It allows for economic growth, it prepares the network for electronics which must be high speed and common control in nature, and it takes advantage of the latest engineered developments in the telephone switching art, developments which cannot be seriously threatened, on present information, for at least 10 years.

### ACKNOWLEDGMENT

The author wishes to thank the Director-General and Engineer-in-Chief of the Postmaster-General's Department for granting permission to use material contained in this paper. Contributions towards the work underlying this paper have come from several Engineers in the Post Office whose assistance is appreciated and acknowledged. In particular, however, he wishes to acknowledge contributions by Messrs. C. I. Cruttenden, N. A. S. Wood, N. M. H. Smith and B. McKinley to the various phases of this investigation. The author also wishes to record his appreciation of the editorial assistance given him by Messrs. C. I. Cruttenden and C. J. Griffiths.

## INDEX—VOLUMES 7 TO 12

A comprehensive index, covering the contents of volumes 7 to 12 inclusive, has been completed and is ready to be printed. It will be similar to the index for volumes 1 to 6 which was issued in February, 1948, and which has filled a very useful need to readers who refer at times to past issues of the Journal. However, it is not considered desirable for the printing costs to be shared by all readers of the Journal, some of whom will make no use of the index, and it has been decided to make a charge of three shillings (3/-), the estimated printing cost, for each copy. Any reader or organisation requiring the index is requested to fill in the slip included under the front cover and forward it, together with a remittance for three shillings (Australian currency, including postage), either to the State Secretary of the State of residence, or to the General Secretary if resident overseas. Australian subscribers could assist the Society greatly by forwarding remittances before the 20th November, as it is desired to make firm printing arrangements then with a view to distribution before the 20th December. Copies of the earlier index for volumes 1 to 6 are still available and can be supplied at a cost of 1/6 each, including postage.