

(Model.)

2 Sheets—Sheet 1.

F. A. GOWER.
Telephone.

No. 236,021.

Patented Dec. 28, 1880.

Fig. 1.

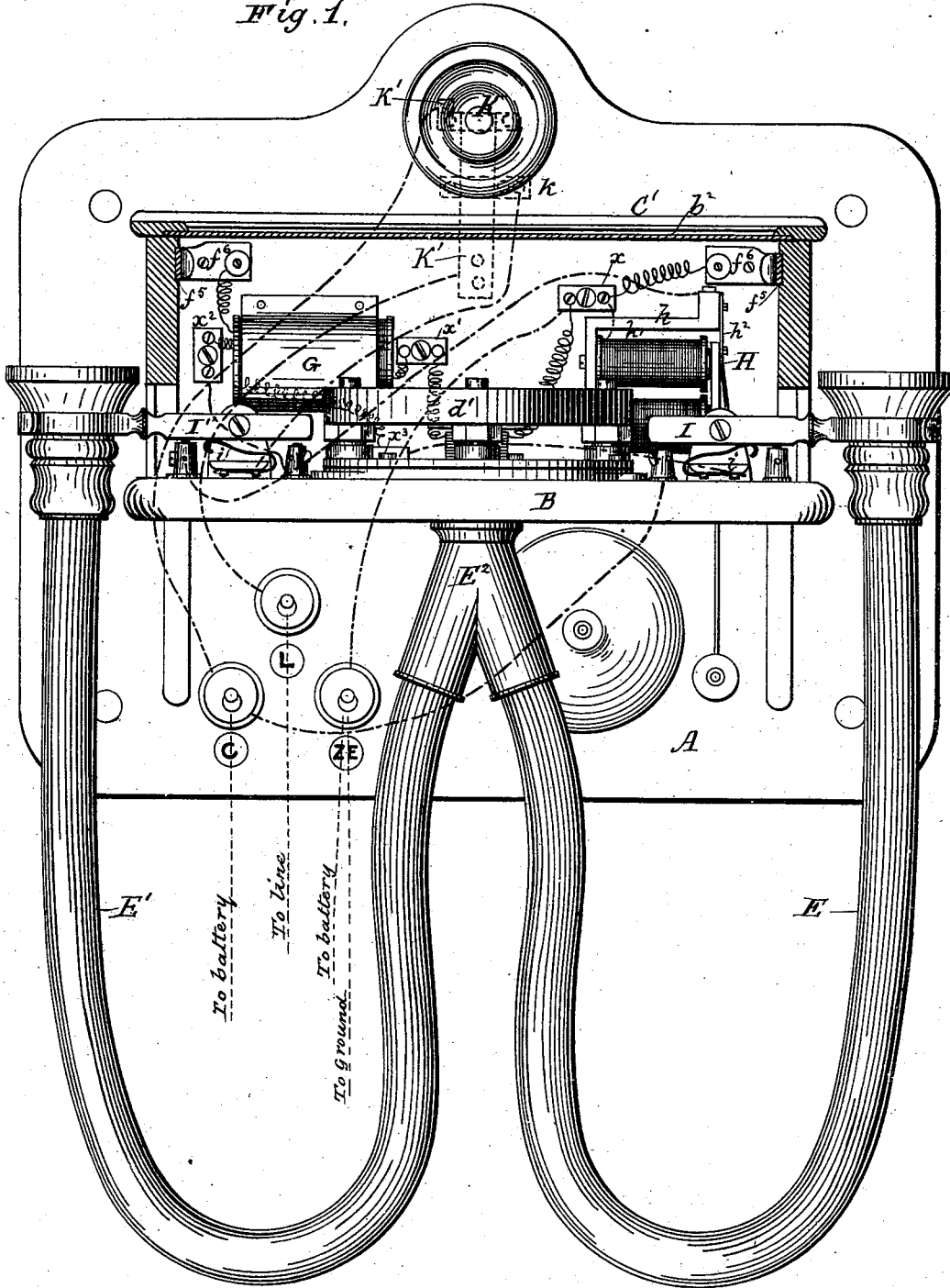

Witnesses:
 E. E. Masson
 Philip Haining

Inventor
 Frederic Allen Gower
 by A. Pollack
 his Atty.

F. A. GOWER.
Telephone.

No. 236,021.

Patented Dec. 28, 1880.

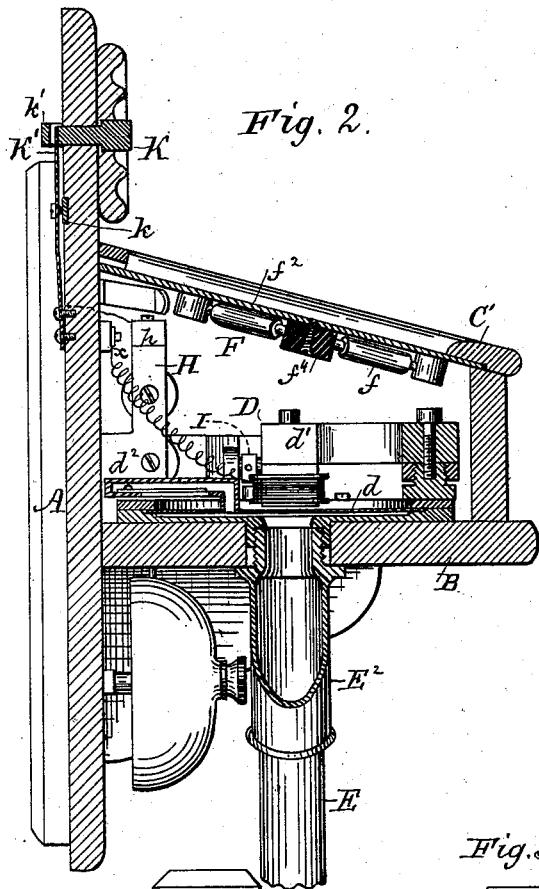

Fig. 2.

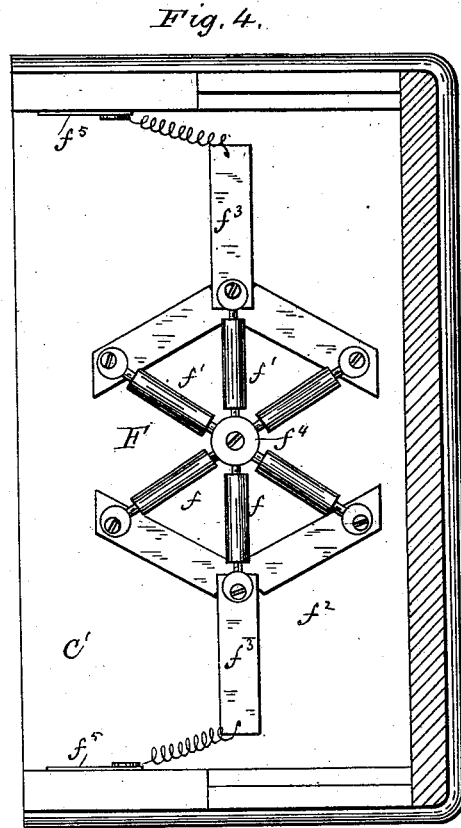

Fig. 4.

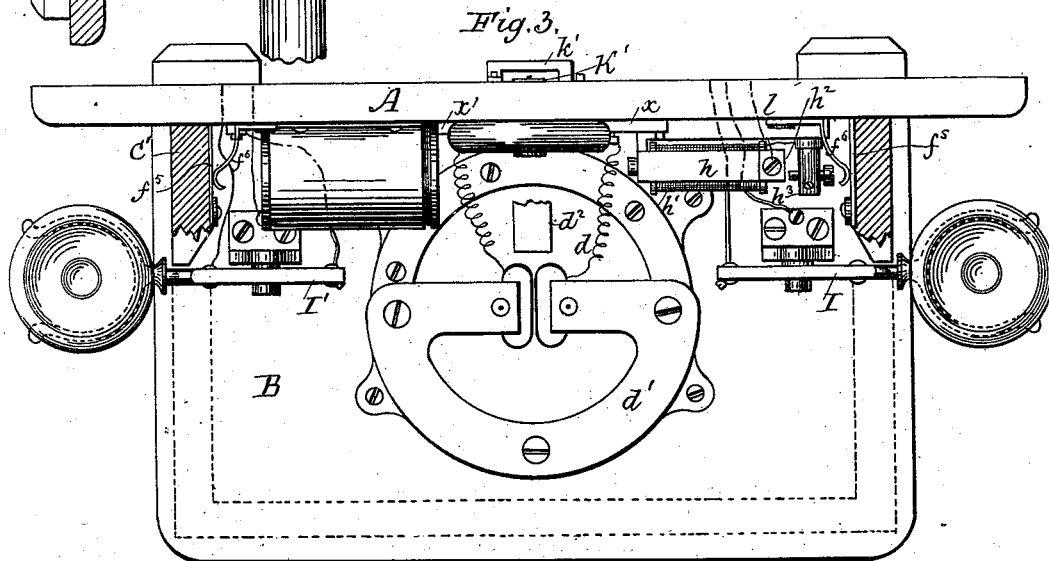

Fig. 3.

Witnesses:
 E. E. Masson
 Philipellawry

Inventor
 Frederic Allen Gower
 by A. Pollok
 his Atty.

UNITED STATES PATENT OFFICE.

FREDERIC A. GOWER, OF PROVIDENCE, RHODE ISLAND.

TELEPHONE.

SPECIFICATION forming part of Letters Patent No. 236,021, dated December 28, 1880.

Application filed September 15, 1880. (Model.)

To all whom it may concern:

Be it known that I, FREDERIC ALLEN GOWER, of Providence, Rhode Island, (temporarily residing at Paris, in the Republic of France,) have invented a new and useful Improvement in Telephones, which improvement is fully set forth in the following specification.

This invention has general reference to telephonic apparatus for speaking and signaling purposes, and principally intended for use at subscribers' offices in a telephone exchange or on private lines, although the invention, or a portion thereof, may be employed at the main or central office of an exchange. It has for its object, mainly, to combine a magneto-electric telephone, capable of serving both as a receiver and transmitter, with a microphone or battery-telephone, in such manner as to secure all the advantages due to the use of a battery in telephonic transmission without its dangers, and also to secure greater efficiency in the operation of the apparatus.

In accordance with this invention, the magneto-electric telephone, in the form, preferably, of the Gower telephone, embodying improvements described in Letters Patent Nos. 217,208, 217,278, and 218,873, granted to me on the 8th of July and 26th of August, 1879, and a battery-telephone of any good and suitable form, but preferably a microphone or carbon telephone of not less than six points of contact, are placed in the same box, and are arranged so that the effectiveness of the Gower telephone as a transmitter, in case the battery should fail or become exhausted, is not diminished.

The microphone is formed by carbon rods and buttons secured on the under side of a vibratory plate, which is, or may be, of wood, and which forms the top of the box. The Gower telephone in the chronometer form, with pneumatic signal, is placed on the lower part of the box, and the sounds are conveyed by a flexible tube or tubes. Within the box is an induction-coil. With its primary circuit the microphone and battery are connected; with its secondary circuit the magneto or Gower telephone and the line. The advantage of being able to use the battery-telephone or to transmit speech without it, should occasion arise, is not only secured, but there is a

gain from the use of the combined instruments in transmission of speech, both in loudness and distinctness.

In speaking against the thin wooden plate which forms the top of the box, and to which the electrodes of the microphone are fastened on the under surface, the vibrations caused therein by the voice produce electrical undulations in the battery-circuit, and these are repeated by induction along the line to the Gower telephone in the instrument at the farther or receiving station. The vibrations, being reproduced with great strength at that station, act upon the microphone in the same box with sufficient power to set up vibrations in the primary circuit, and these are again repeated in the Gower or receiving telephone with added intensity.

In using the pneumatic signal there is also great gain. This signal consists, in its most perfect form, of a musical instrument or reed attached to the vibratory plate of the telephone, as described in one of my before-mentioned patents. On sounding the reed the intense vibration communicated by it to the diaphragm of the magneto-telephone to which it is attached not only generates currents in the bobbins upon the poles of the magnet, but also acts upon the microphone with great power, as the sound is produced inside the same box, and thus the effectiveness of the signal-current sent to line is doubled, without requiring more battery than is used for ordinary speaking. The current thus sent may be made to operate an Ader disk (as described in Letters Patent No. 222,119, granted C. Ader, December 2, 1879) or other signaling instrument with great force, and to effect by suitable instrumentalities any mechanical movement that may be desired.

In my improved apparatus a signal-bell operated by an electro-magnet and of ordinary or suitable construction, and a push-button with connections arranged so that the transmitting-battery can be put directly to line to give a signal, are combined with the telephones. In case these means of signaling should fail to operate, the pneumatic signal could be used.

Suitable switches are used for cutting off the battery-current and leaving the circuit

through the bell when the telephone is not in use.

In order that the person receiving a message may hear with both ears, and also to facilitate the use of the magneto-telephone both as transmitter and receiver, the flexible tube is made double, the two branches being connected with each other and in communication with the interior of the box by the same opening, which is placed opposite the center of the diaphragm. This arrangement is very convenient for the operation of the switch mechanism by gravity, two switch-levers placed at opposite sides of the box and adapted to sustain the two branches of the flexible tube being used.

The invention and the manner of carrying the same into effect will now be more fully described in connection with the accompanying drawings, which form a part of this specification, and which illustrate a telephonic apparatus embodying the invention.

Figure 1 is a front elevation, partly in section, the microphone not being represented; Fig. 2, a central vertical section, the part to the right of the center being shown in elevation; Fig. 3, a plan view, partly in section, the greater part of the cover being removed; and Fig. 4, a bottom view, partly in section, of the cover of the box or case, showing the construction of the microphone.

The same letters indicate like parts wherever they occur.

A represents the back of the box, which is secured to the wall; B, the bottom, securely fastened to and projecting from the back; and C', the removable cover, all of which parts may be formed of wood. D is a magneto or Gower telephone; E E', the two branches of a double sound-conveying tube; F, a microphone; G, an induction-coil; H, an electro-magnetic circuit-breaking bell; I I', gravity-switches operated by the weight of the flexible tubes E E', and K a push-button for operating a signal-switch, K'.

The construction and arrangement of the magneto-telephone is best shown in Figs. 2 and 3. In the bottom B of the telephone-box is an opening, through which the end of the bifurcated tube E² passes. This tube is, or may be, of metal, and with it the flexible branches E E' are connected. In the front of and above this opening the metallic diaphragm *d* is stretched by means of a ring and base-piece, which latter is screwed to the bottom of the case, and is provided with a screw-threaded opening to receive the end of the tube E². Above the center of the diaphragm are placed the depending poles of the permanent magnet *d'*, held and adjusted by the aid of screws and nuts, as shown in Fig. 2. The pole-pieces are surrounded by bobbins of insulated wire. The form of the magnet is clearly shown in Fig. 3. The diaphragm *d* is perforated, and on its upper surface is secured the musical reed-instrument *d*², as shown, so

that it can be operated by the passage of air through the opening. The form of magnet and the pneumatic signal are particularly described and claimed in my before-mentioned patents.

The microphone F is formed by the carbon rods, of which six are shown, divided into two sets, *f f'*, secured on the under side of the thin wooden plate *f*², that constitutes the top of the box. Each carbon rod has one end supported by a carbon button in contact with the copper strips *f*³, and the other resting in contact with a common button, *f*⁴. Screws pass through and fasten all the buttons to the plate *f*². The conductors *f*³ are connected by flexible wires with the strips *f*⁵, with which the springs *f*⁶, secured to the back of the case, make contact, as shown in Fig. 3, when the cover is placed in position.

The induction-coil and electric bell are fastened to the back of the box.

The switches I I' are simple levers, operated in one direction by springs *i'*, and in the other by the weight of the flexible tubes.

The signal-switch K' has a front contact, *k*, and a back contact, *k'*.

The bell H is shown as a vibrating or automatic circuit-breaking bell.

The electrical connections are as follows: From binding-post L a wire runs at the back of the box to the signal-switch K'. From the front contact of this switch a wire runs to the standard of the switch-lever I', which latter is thus normally in electrical connection with binding-post L. From the left-hand contact of this lever a wire runs to the metallic frame *h*, which supports the bobbin *h'*, and with which the spring *h*², carrying the armature and bell-hammer, is connected. With the back contact, *h*³, Fig. 3, of the spring *h*² is connected one end of the insulated wire forming the bobbins *h'*, the other end being connected with the connection-piece *x*. This piece is connected with the binding-post Z E, with the right-hand spring, *f*⁶, and also with one end of the wire of the magneto-telephone coils or bobbins. The other end of the telephone-coils is connected, through the connection-piece *x'*, secondary circuit of the induction-coil G, connection-piece *x*², and conducting-wire, with the right-hand contact of lever I'. From the binding-post C a wire runs to the back contact, *k'*, of signal-switch K', and another wire to the left-hand contact of switch-lever I. The lever I is in electrical connection, through its standard, a conducting-wire, and metal piece *x*³, with one end of the primary circuit of the induction-coil. The connections with the primary circuit of the induction-coil are not shown in Fig. 3. The other end of this circuit is connected with the left-hand spring, *f*⁶. "Line in" is connected with the post L, "line out," or a wire to earth, with post Z E, the zinc or negative pole of the battery also with Z E, and the carbon or positive pole with post C. Normally, therefore, the circuit would be from

post L, through the switch-lever I' and call-bell, to post Z E and earth, or to next station, the telephones and battery being cut out. The line is normally free from current, and when the central office desires to call the station the operator puts his battery to line and the current passing through the vibratory bell rings it continuously so long as the battery and bell continue in circuit. By pressing upon push-button K the line would be connected, through the back contact of switch K' and battery placed in the loop between the posts C and Z E, to ground, or to a continuation of the line beyond, and the switch K' being separated from its front contact, the call-bell will of course be cut out. A signal or call can thus be given to another station or the central office of an exchange without sounding the bell at the calling-station.

When the flexible tubes are removed from the switch-levers I I', these are acted upon by their springs and make new contacts, cutting out the bell and establishing the following circuits: The main line will extend from the post L, through switch K', front contact, *k*, lever I' and its right-hand contact, secondary circuit of induction-coil G, and magneto-telephone coils, to post Z E, and thence to earth or to next station. A local-battery circuit will be completed through the microphone and primary circuit of the induction-coil as follows: from positive pole of battery to post C, to left-hand contact of lever I, through lever I, wire and connection-piece *x*⁵, primary circuit, to left-hand spring, *f*⁶, to microphone, to right-hand spring, *f*⁶, to connection-piece *x* and post Z E, and thence to negative pole of battery.

In using the instruments the words are spoken to the plate forming the top of the box, the vibrations in which act to vary the resistance in the local circuit by means of the carbon rods or microphone, and thus produce undulations in the battery-current. These undulations are repeated by the induction-coil on the main line. The words from the distant station are received by the magneto-telephone through the flexible tubes, one being applied to each ear. The microphone, combined with the magneto-telephone, being acted upon with sufficient power by the vibrations in the latter to set up vibrations in the primary circuit connected with the former, gives increased loudness and distinctness to the reproduced sound by the aid of said vibrations.

In case the battery should not operate, the magneto-telephone only is used, one tube being employed for speaking and the other for listening.

In order to use the pneumatic signal, one tube may be stopped with the hand and air be blown into the other. It is obvious that when this is to be used the apparatus at the farther station should be adapted to respond to the vibrations thus produced. An Ader disk could, for example, be substituted

for the circuit-breaking bell or the magneto-telephone, or both telephones could be left in circuit.

Many modifications could be made in construction and other details without departing from the spirit of this invention.

Although the Gower telephone is best adapted for use in combination with a microphone, as described, on account of the great strength of magnet, the invention is not limited thereto, but includes other forms of any ordinary or suitable construction having sufficient strength to operate as set forth.

Having thus fully explained the said invention and the manner of carrying the same into effect, what I claim is—

1. The combination of a magneto-telephone in the same box with a microphone, the said instruments being connected electrically by means substantially as described, and adapted to be influenced by each other in operation, as set forth.

2. A microphone or battery-transmitter, in combination with a strong magneto-telephone with separate diaphragm, said instruments being electrically connected by means substantially as specified, so that vibrations in the microphone are reproduced in the magneto-telephone, and mechanically connected, as indicated, so that vibrations are conveyed from one to the other independent of the electrical connections.

3. In a telephone system, the combination, with a magneto-telephone provided with one or more flexible sound-conveying tubes and having its coils connected in the main line, of a microphone or battery-transmitter with a separate diaphragm from that of the magneto-telephone, placed in a local-battery circuit, but connected with the main line, so that the electrical undulations in said circuit are reproduced on the main line, substantially as described.

4. A telephone comprising a box with vibratory top, one or more electrodes connected with said top, a magneto-telephone inclosed in said box and provided with a suitable diaphragm, electrical conductors connected as indicated, and one or more sound-conveying tubes or passages for conveying sound to or from said diaphragm, substantially as described.

5. A magneto-telephone and microphone or battery-transmitter electrically connected with each other, combined with a reed or musical instrument which, when sounded, simultaneously causes vibrations in both the magneto-telephone and microphone, substantially as described.

6. A telephonic apparatus comprising a battery-transmitter, an induction-coil in one circuit of which said transmitter is connected, a magneto-telephone having its coils connected with the other circuit, double sound-conveying tube for the magneto-telephone, and two automatic switches adapted to be operated by

said double tube, and acting to break the circuit of the transmitter and cut out the magneto-telephone when depressed, and to restore the said circuit and bring in the magneto-telephone when released, substantially as described.

In testimony whereof I have signed this

specification in the presence of two subscribing witnesses.

FREDERIC ALLEN GOWER.

Witnesses:

A. POLLOK,

ROBT. M. HOOPER.