

(No Model.)

2 Sheets—Sheet 1.

L. E. SIMONEAU.
AUTOMATIC TELEPHONE SYSTEM.

No. 520,246.

Patented May 22, 1894.

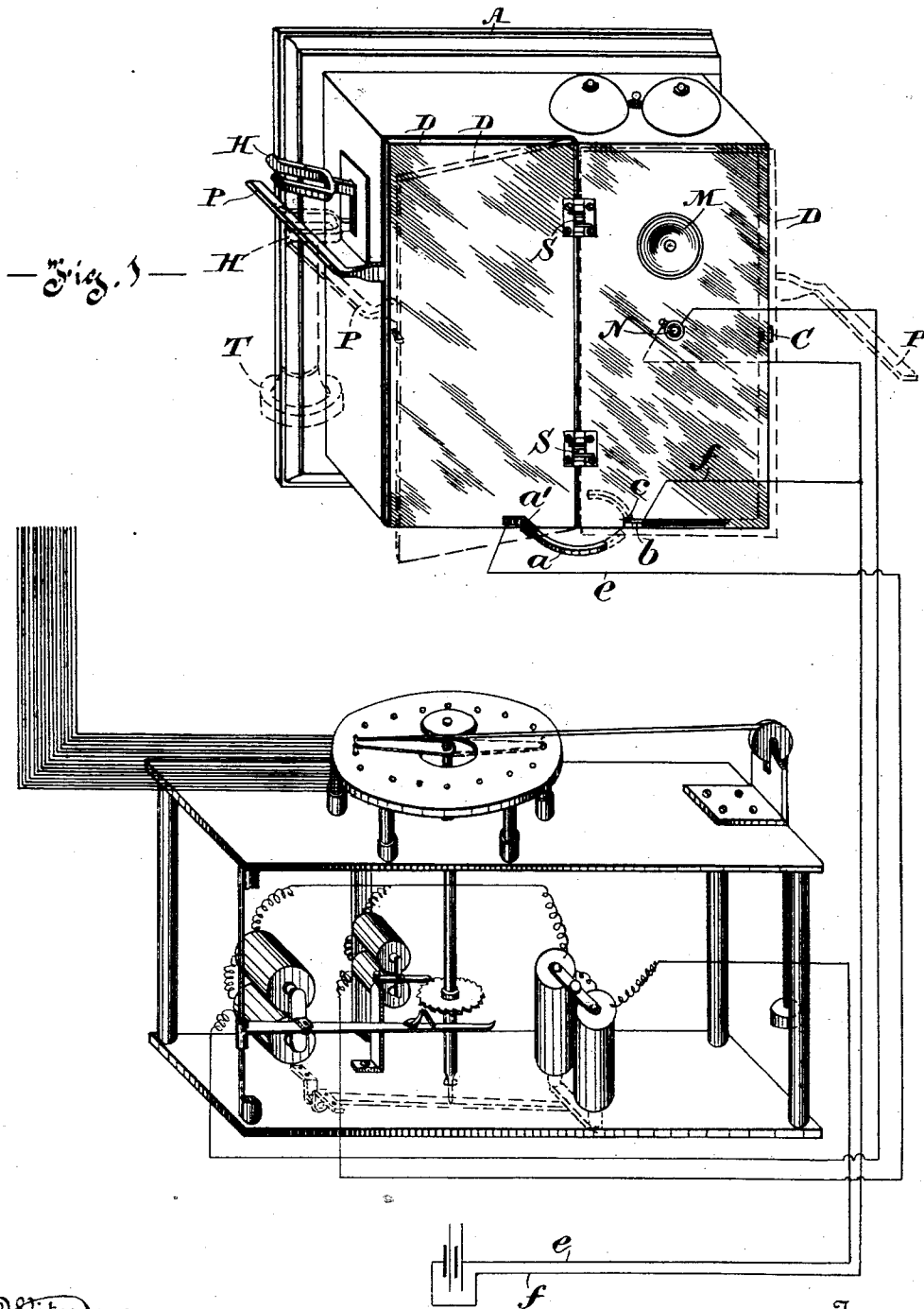

Witnesses
[Signature]
 R. W. B. Stinson

Inventor
 Louis E. Simoneau
 By his Attorney
[Signature]

(No Model.)

2 Sheets—Sheet 2.

L. E. SIMONEAU.
AUTOMATIC TELEPHONE SYSTEM.

No. 520,246.

Patented May 22, 1894.

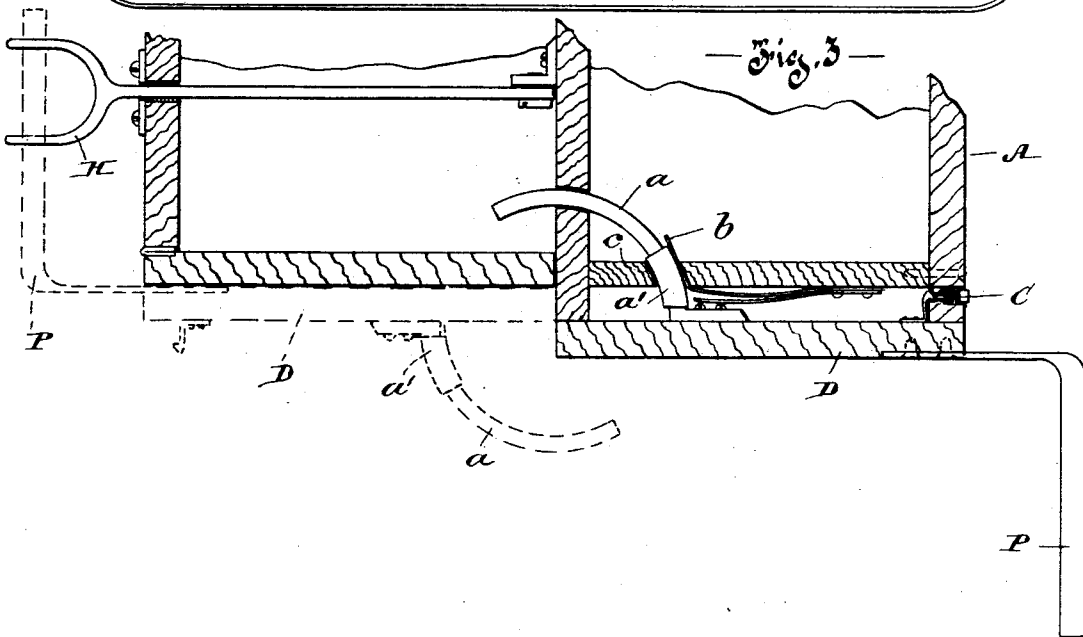
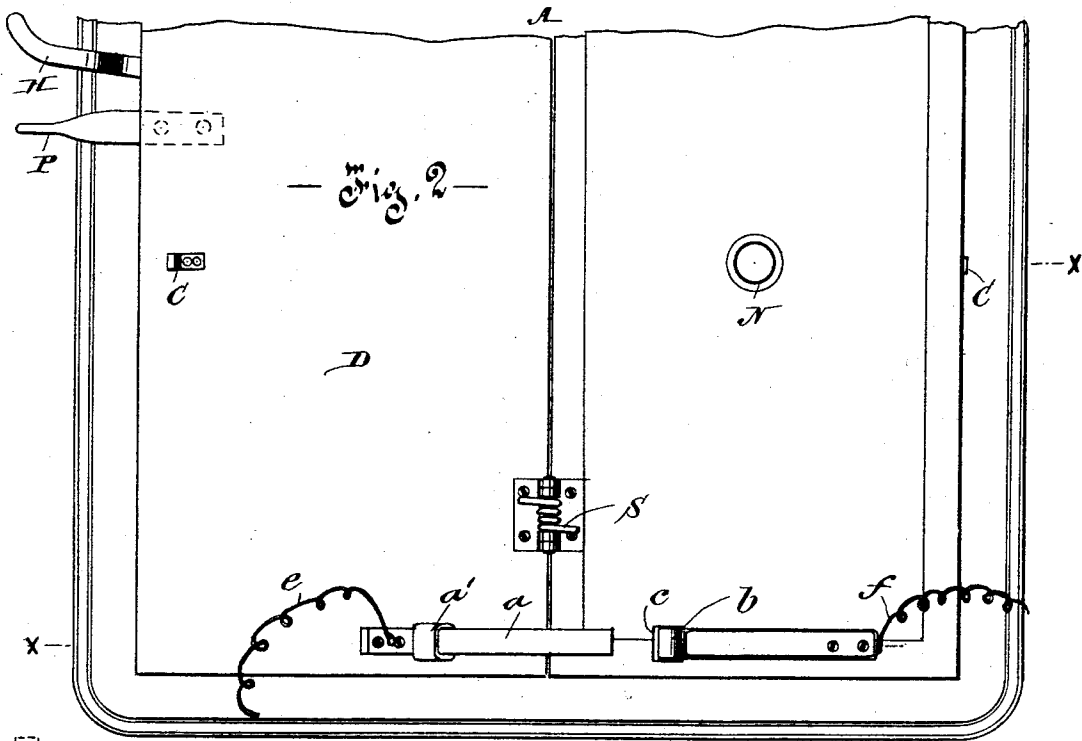

Witness
Wm. H. Feat
Fred Sears

Inventor
Louis E. Simoneau
 By his Attorney
Wm. H. Feat

UNITED STATES PATENT OFFICE.

LOUIS E. SIMONEAU, OF MONTREAL, CANADA, ASSIGNOR TO THE AUTOMATIC TELEPHONE AND ELECTRIC COMPANY OF CANADA, OF SAME PLACE.

AUTOMATIC TELEPHONE SYSTEM.

SPECIFICATION forming part of Letters Patent No. 520,246, dated May 22, 1894.

Application filed July 11, 1893. Serial No. 480,195. (No model.)

To all whom it may concern:

Be it known that I, LOUIS EDWARD SIMONEAU, of the city of Montreal, in the district of Montreal and Province of Quebec, Canada, have invented certain new and useful Improvements in Automatic Telephone Systems; and I do hereby declare that the following is a full, clear, and exact description of the same.

This invention relates more particularly to the systems having an automatic central office apparatus worked from the several sub-stations and requiring means for returning the operating parts at the central to their normal position after connecting two sub-stations. The means for returning such operating parts to their normal position heretofore has included a pawl and ratchet,—battery circuit,—gravity pull—and electro-magnet, the battery circuit being controlled by a push button at the sub-station, and the object of the present invention is to provide an arrangement which shall be an effective guard against the present chances of neglect or forgetfulness in pressing such push button after conversation is finished, which omissions are apt to interfere to some extent with the working of the system.

The arrangement I have referred to consists in an automatic "release" or make-and-break connection operated by a movable part of the sub-station instrument or outfit, such as a door to cover up the face of the transmitter opening keyboard, &c., and characterized by a prolongment of the contact. For full comprehension however of the invention, reference must be had to the annexed drawings forming a part of this specification in which like symbols indicate corresponding parts, and wherein—

Figure 1 is a view showing a portion of an automatic telephone system, *i. e.*, an automatically operated central station instrument in perspective, and one sub-station instrument also in perspective, the two instruments being connected diagrammatically; Fig. 2 a front elevation of the lower portion of a sub-station instrument with door open; and Fig. 3 a sectional view taken on line $x-x$ Fig. 2 but with door closed.

In carrying out my invention I prefer to use a single box or casing such as A which shall inclose all the instrumentalities of the sub-station except the telephone T itself which will be hung as usual upon the customary hook H projecting through one side of the box, a flap or door D being used to cover up the mouth-piece M of the transmitter and the key board, indicated by press button N, so that on all occasions in order to secure connection with another sub-station it will be necessary to open such door and after the conversation is finished it will be equally necessary to close the door in order to hang up the telephone.

To open the door I have arranged that it will only be necessary to press a catch C to one side so that springs S on the hinges of the door or other automatic means will throw the door open, and to insure the closing of same after the telephone is removed from the hook becomes located across such hook so that it is necessary to close the door in order to clear the hook and hang up the telephone. The act of opening and closing the door serves as a make-and-break connection which controls the means for returning the operating parts at the central to their normal position, which make-and-break connection is preferably of the following construction:

The door carries a curved or segmental arm forming a contact *a* projecting from the inside of same near its hinged edge and bearing insulation at *a'*, and the box has an insulated spring contact *b* located near its bottom side and with its free end terminating at one side of an aperture *c* in the front of the casing through which the curved contact *a* passes and making connection with the contact *b* in so doing.

The central office apparatus which is simply indicated as that pertaining to the "Strowger system" and given as an example merely, need not be described in detail as it is not changed in any way, in fact the operation is substantially the same as formerly the difference being that the door is opened and closed instead of the usual push button being operated. I may point out however that *e* and *f* are the

respective ends of the usual battery circuit with terminals for releasing purposes at the contacts *a* and *b*. The normal position of the parts is shown in Fig. 3 with the insulated part *a'* of the curved contact arm *a* in contact with the spring contact *b*, in which condition the sub-station is capable of being called by any other sub-station.

To use the instruments the operator presses catch *C*, the door is thrown open automatically by the spring hinges, the "release" battery circuit to central is closed while the contact *a* is traversing *b* and consequently the operating parts at the central are brought to their normal position if by any chance they were not previously. The arm *P*, when the door is thrown open, bears against the telephone hook until the telephone is removed, when, by the elevation of the hook, the door opens fully and the arm is located beneath the hook. The operator however makes his connection in the usual way by pressing the keys or buttons (one or more) and ringing before he removes the telephone and when he comes to replace it he is obliged to close the door before he can do so (as the arm *P* is in the way) with the result that the "release" is again operated and the central office parts returned to their normal position.

30 What I claim is as follows:

1. As a part of a sub-station telephone circuit, or set; a single box or casing, adapted to contain the several instrumentalities thereof, excepting the telephone and a portion of the telephone hook; a door, hinged to such box, normally closed to prevent the use of the instruments, and, when opened, allowing of their use, and a pair of electrical contact parts, one part being carried by said box and the other part carried by said door so as to be movable therewith and the part carried by the door being adapted upon a continuous movement of said door in one direction to have a sliding connection with the stationary part and so effect a prolonged electrical connection between the two and subsequently in the same movement effect the breaking of such connection, the whole operating in connection with and controlling an electrical circuit with terminals at said contact parts.

2. The combination of box *A* with the sev-

eral instrumentalities of a telephone set arranged therein, door *D* and spring actuating parts for automatically throwing same open, a locking device for holding same closed, contact *a* bearing insulation *a'*, spring contact *b*, and a battery circuit, for the purpose specified, with terminals at said contacts as set forth.

3. The combination of a box or casing *A* with the several instrumentalities of a telephone set arranged therein and the end of the telephone hook projecting therethrough, door *D* carrying an arm or projection adapted, when the telephone is removed from its hook and the door fully opened, to become located across said hook for the purpose specified, a make-and-break electrical connection parts of which are carried respectively by said box and door, and the whole adapted to control an electrical circuit with terminals at said make and break connection.

4. The combination of box *A*, with the several instrumentalities of a telephone set arranged therein and the end of the telephone hook projecting therethrough, door *D* and spring actuating parts for automatically throwing same open, and a locking device for holding same closed, a projecting arm *P* carried by said door, for the purpose specified, the contact *a* bearing insulation *a'*, the spring contact *b* and a battery circuit with terminals at said contacts as set forth.

5. In an automatic telephone system, the combination with an automatically movable part of the sub-station outfit and the "release" circuit acting when closed to return the operating parts of the "central" to their normal position after establishing a connection,—of a make-and-break connection closing said release circuit, the same consisting of a pair of electrical contacts one of which traverses the other for a protracted period to secure a prolonged electrical connection or closing of the circuit and finally breaks or opens said circuit by disconnection the one from the other.

Montreal, 19th day of June, 1893.

LOUIS E. SIMONEAU.

Witnesses:

WILL. R. MCFEAT,
FRED. J. SEARS.