

No. 626,983.

Patented June 13, 1899.

W. DECKER.
AUTOMATIC TELEPHONE EXCHANGE SYSTEM.

(Application filed Aug. 3, 1896.)

(No Model.)

5 Sheets—Sheet 1.

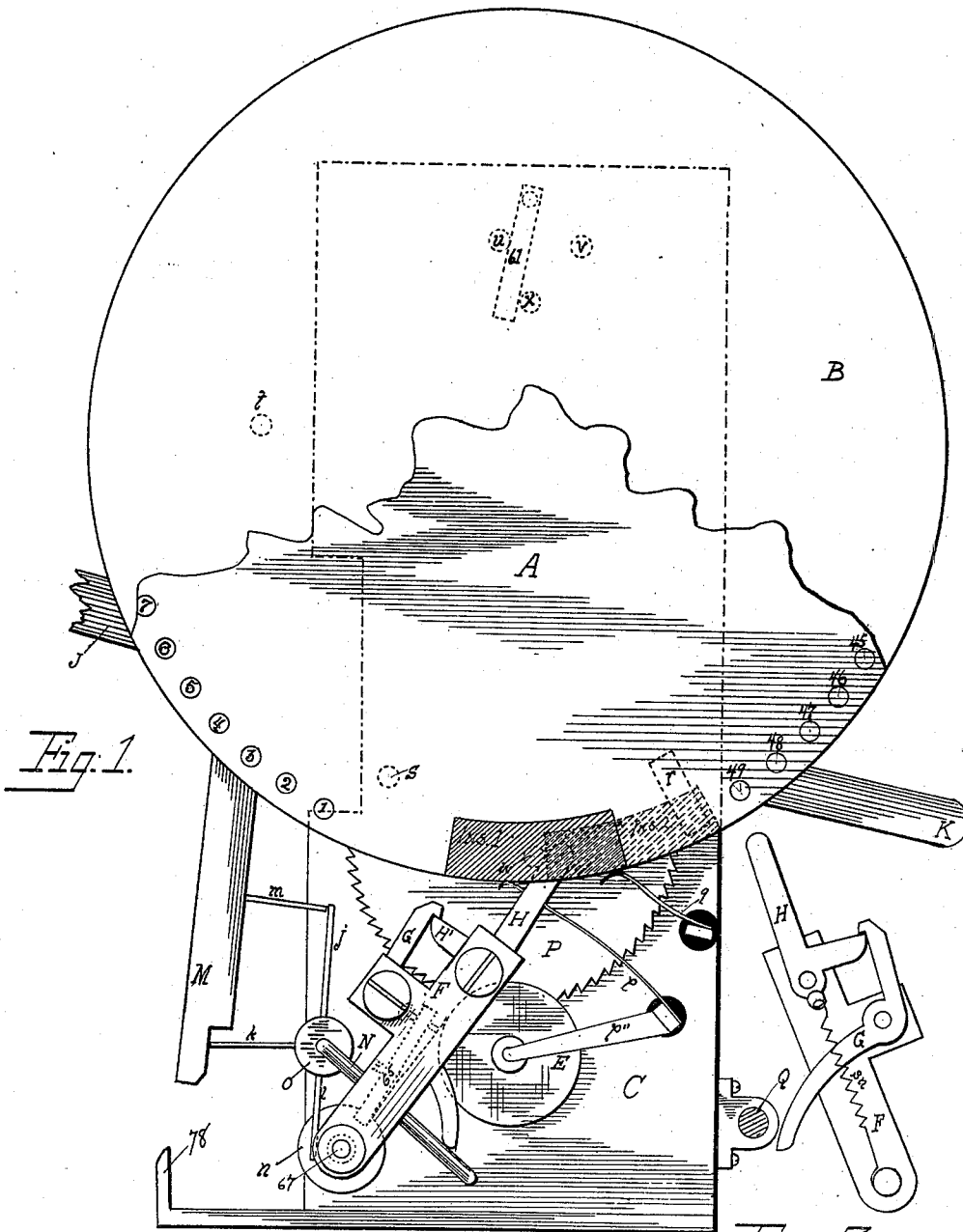

Fig. 1.

Fig. 3.

Witnesses:
E. A. Kinckley,
John P. Bell

Inventor:
Ward Decker

No. 626,983.

Patented June 13, 1899.

W. DECKER.

AUTOMATIC TELEPHONE EXCHANGE SYSTEM.

(Application filed Aug. 3, 1896.)

(No Model.)

5 Sheets—Sheet 2.

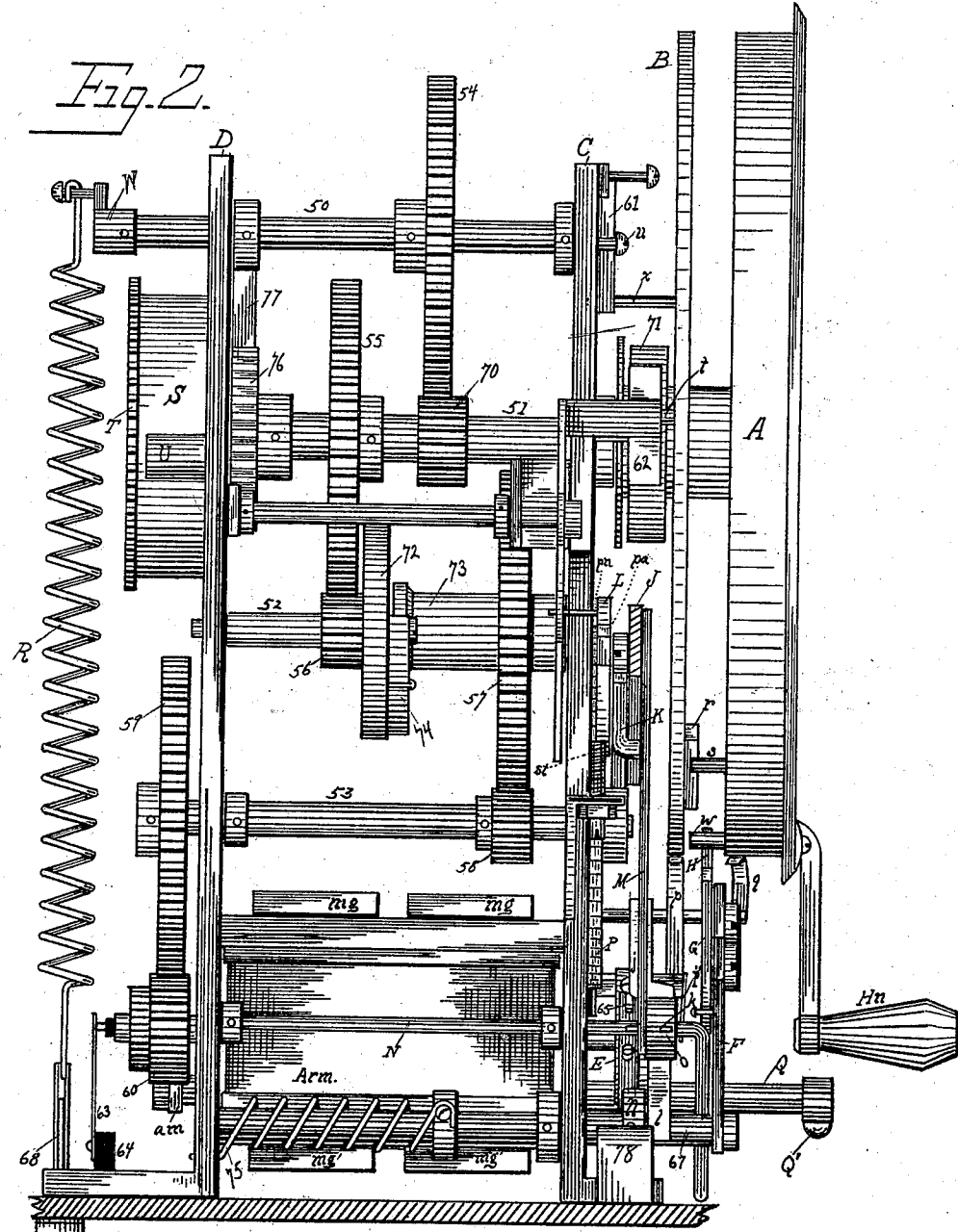

Witnesses:
E. A. Hunchley
John P. Bell

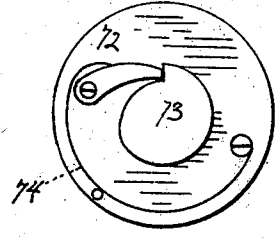

Inventor:
Ward Decker

No. 626,983.

Patented June 13, 1899.

W. DECKER.
AUTOMATIC TELEPHONE EXCHANGE SYSTEM.

(Application filed Aug. 3, 1896.)

(No Model.)

5 Sheets—Sheet 3.

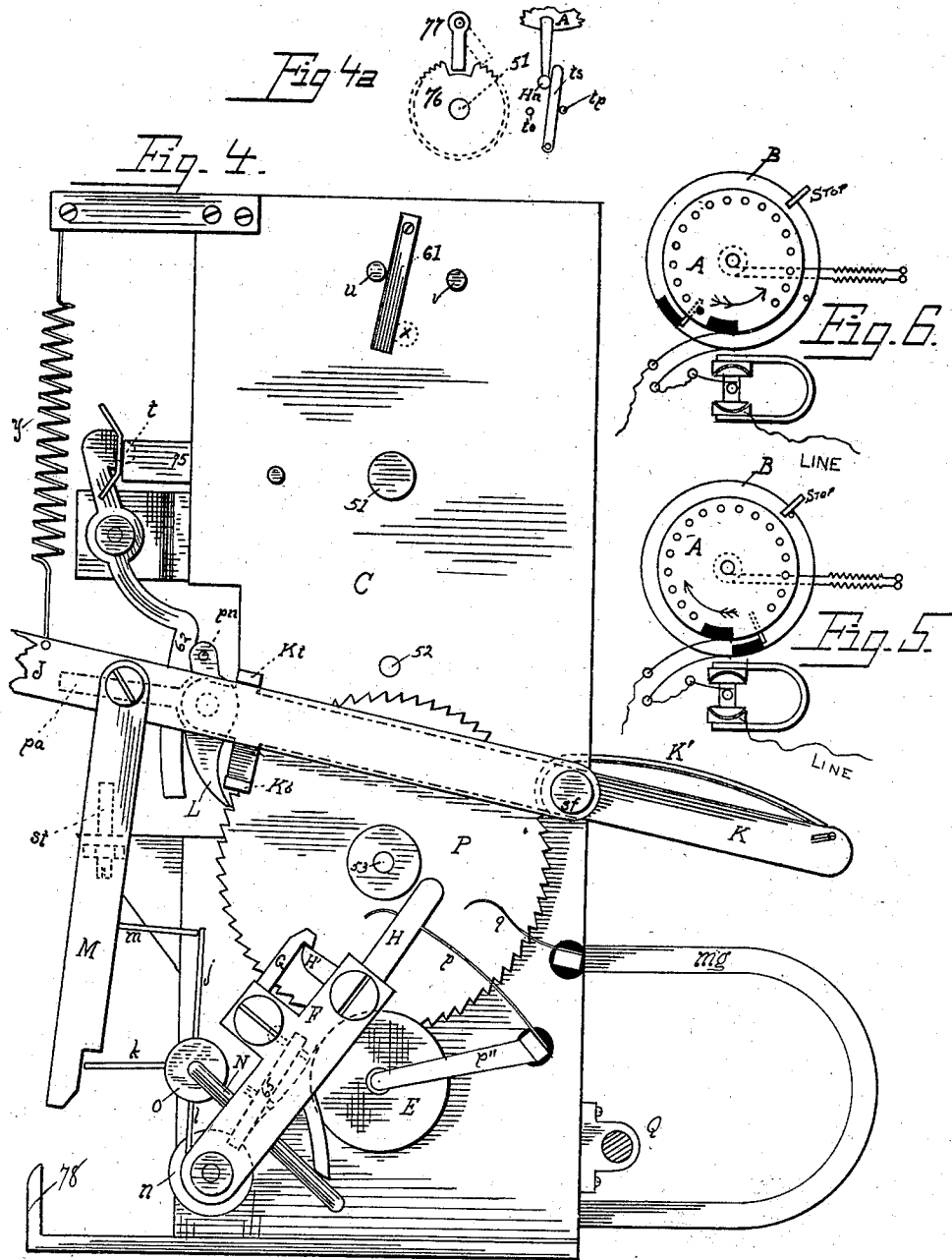

Witnesses:

E. A. Hinchley.
John T. Bell

Inventor:

Ward Decker

No. 626,983.

Patented June 13, 1899.

W. DECKER.

AUTOMATIC TELEPHONE EXCHANGE SYSTEM.

(Application filed Aug. 3, 1896.)

(No Model.)

5 Sheets—Sheet 4.

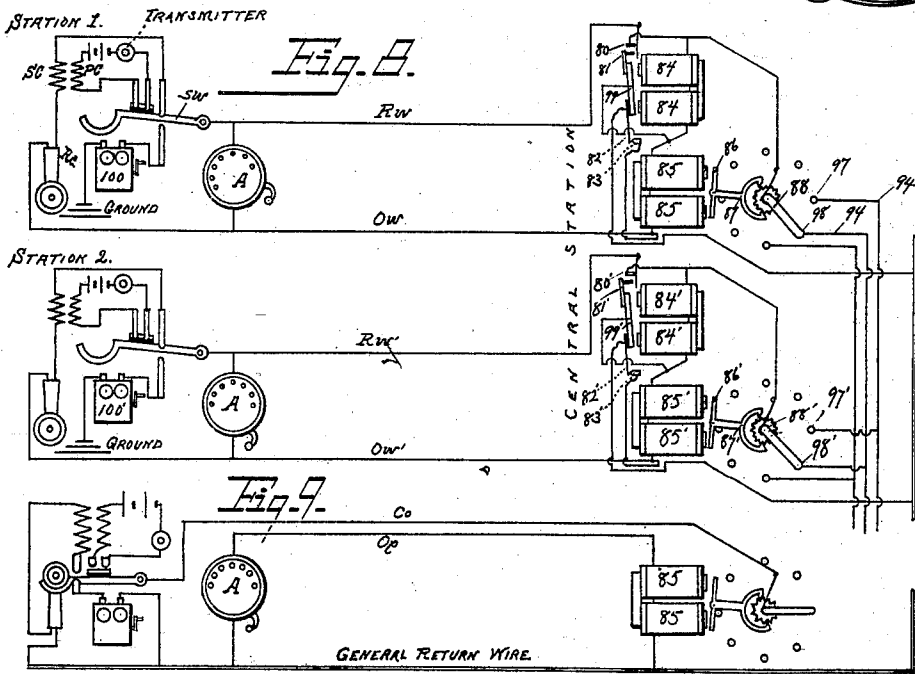
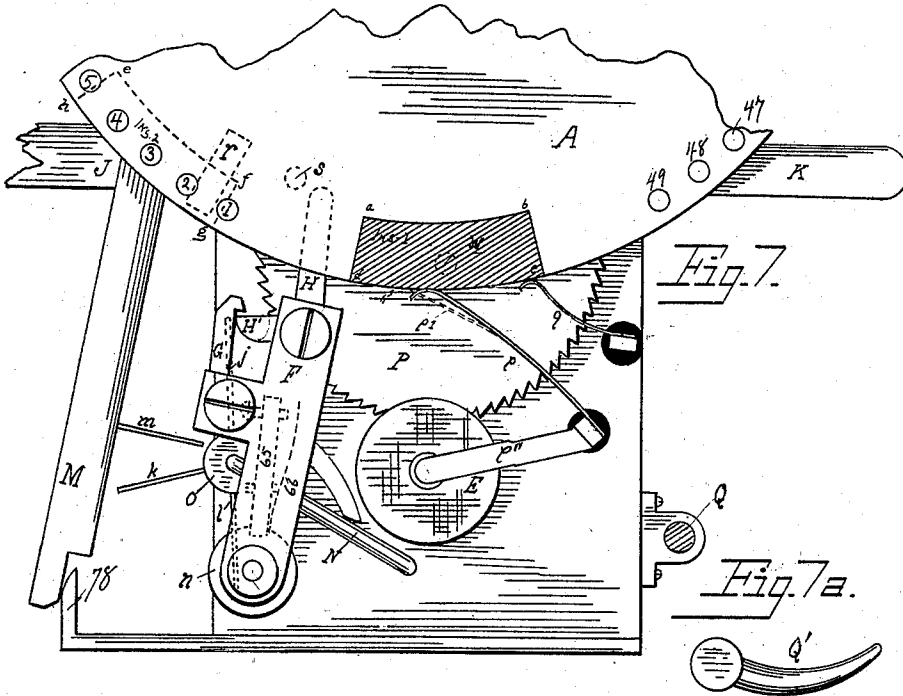

Witnesses:

John P. Bell
E. A. Hinchley

Inventor:

Ward Decker

No. 626,983.

Patented June 13, 1899.

W. DECKER.

AUTOMATIC TELEPHONE EXCHANGE SYSTEM.

(Application filed Aug. 3, 1898.)

(No Model.)

5 Sheets—Sheet 5.

Fig. 10.

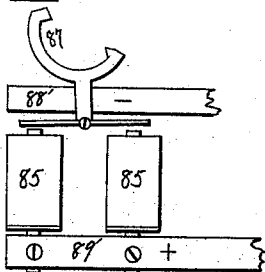

Fig. 11.

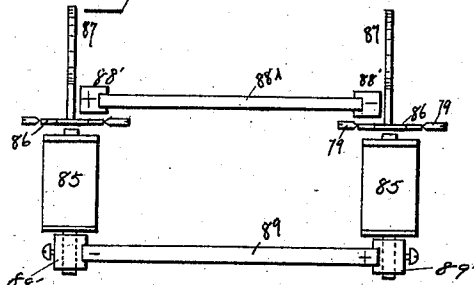

Fig. 12.

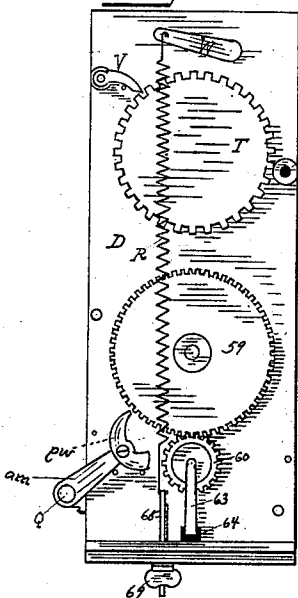

Fig. 14.

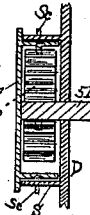

Fig. 13.

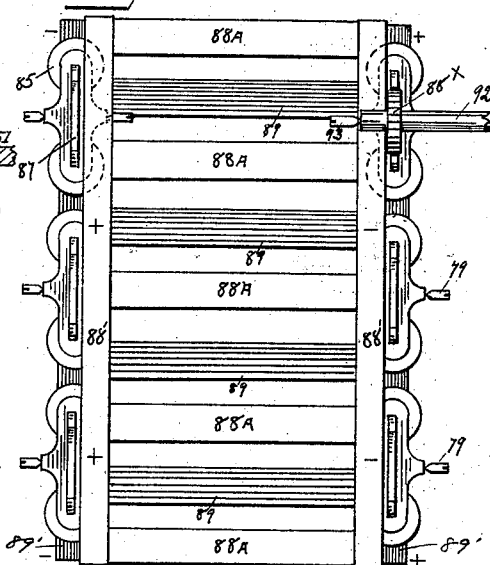
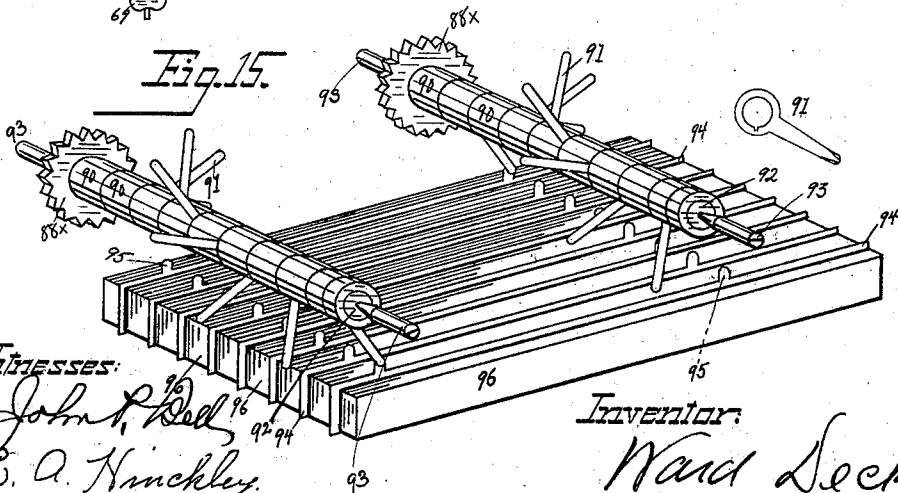

Fig. 15.



Witnesses:
John P. Bell
E. A. Hinckley

Inventor:
Ward Decker

UNITED STATES PATENT OFFICE.

WARD DECKER, OF OWEGO, NEW YORK.

AUTOMATIC TELEPHONE-EXCHANGE SYSTEM.

SPECIFICATION forming part of Letters Patent No. 626,983, dated June 13, 1899.

Application filed August 3, 1896. Serial No. 601,454. (No model.)

To all whom it may concern:

Be it known that I, WARD DECKER, a citizen of the United States, residing at Owego, in the county of Tioga and State of New York, have invented a new and useful Automatic Telephone or other Electrical Exchange System, of which the following is a specification.

My invention relates to improvements in telephone-exchange systems in which the central-station switchboard is operated by currents of electricity sent from the subscribers' stations; and the objects of my invention are, first, to do away with all batteries as a source of power to operate the switchboard; second, to limit the number of wires from each subscriber to two; third, to furnish complete metallic circuits for conversational purposes free from any ground connection and with all operating-electromagnets bridged across the two conductors, as in the best modern practice in the operation of manual switchboards; fourth, to construct a secret-service system where it is practically impossible to overhear parties conversing and yet enable three or more subscribers to all converse at once with entire freedom from being overheard whenever mutually agreed upon; fifth, to operate a step-by-step movement with an alternating current produced mechanically, thereby doing away to a large extent with circuit-breakers, pole-changers, and similar arrangements liable to derangement on account of poor contacts, and, sixth, to use currents of much higher voltage than is practicable with battery-currents, thereby enabling the operation of the switchboard to be performed over much longer lines.

In carrying out my invention I make use of an apparatus which I will term a "dial" instrument for generating the currents used to operate the central-station switchboard. This dial instrument consists of two dials through which the current is run by means of a spring bearing against the edge of each, into which edge a piece of insulating material is placed. In a normal position the dials stand in such a manner that the spring on the edge of the inside dial is in metallic contact with it, while the spring of the other dial stands on the insulating material. Suitable holes are placed around the edge of the front dial, through which a plug can be inserted. The front dial is attached rigidly to a main

shaft, and in connection with a spring similar to a clock-spring and suitable gears motion is imparted to the armature of a magneto-electric machine. The back dial runs loosely on the shaft and by means of another clock-spring is held against a stop. The plug being placed in a desired hole and the front dial revolved by hand turns one revolution, and in doing so the plug catching a stop on the back dial, revolves it part of a revolution, just what part depending upon the location of the plug in the front dial. At the same time the spring is wound up, and upon releasing the handle of the front dial and starting the instrument the dial starts to travel back, and by means of the gearing the magneto-machine starts. The front-dial contact-spring, as before stated, stood at first upon the insulated part and now stands at the same point, because the dial has made a complete revolution, and no current is generated until the spring gets over the insulation. In practice about four turns is allowed to get the generator up to speed. It should be stated that the magneto-generator is connected to the spring and line, and when the contact-spring reaches the metallic portion of the dial current will flow until the other contact-spring on the other dial reaches its insulated section. At that instant the plug in the front dial strikes a lever, which actuates a brake and stops the generator. The spring on the back dial now rests on the first edge of the insulating material in precisely the same manner as the other spring did on the front dial when starting. A number of alternations of current has been sent over the line, depending upon the distance the insulating-sections were separated by the plug in the front dial. Hanging up the telephone-receiver releases the brake, starts the mechanism, the generator-armature revolves another four times before current is generated, gets up speed, current is sent over the line, resetting the central-station instrument, and, finally, the instrument comes to rest with the front-dial spring on the insulating material, thereby stopping the current. Each subscriber is provided with a switching instrument at the central station, as hereinafter described. This use of a mechanical generator is one of the distinguishing features of

my invention, the preferable form being the ordinary magneto-generator used in telephone call-bell service. As before stated, this generator is designed to be run by a spring-motor, which is wound up at each operation by the subscriber in the act of operating his instrument. One of the first difficulties to overcome in a system of this kind was the inability to get the armature under motion or to reach a certain speed every time on starting before any current was sent over the line, for starting from complete rest it is evident that until a somewhat high rate of speed is attained the resulting current will be comparatively weak and liable not to operate the switch at the central station. It was also found that in practical operation a comparatively weak spring was capable of producing plenty of power after the mechanism was in motion; but in order to start from a state of rest a very strong spring became necessary, which, unless some complicated governing apparatus was attached, ran the generator too fast. Consequently devices were adopted to start the instrument first by hand and afterward when resetting the switchboard automatically. I attain these objects by the mechanism and disposal of circuits shown in the accompanying drawings, in which—

Figure 1 is a front view of the transmitting dial instrument with a portion of the front dial, handle of dial, permanent magnets, and receiver-hook omitted and shows the position of the insulated sections on both dials, the brake and stopping mechanism, and portions of the starting arrangement. The dial as shown is at rest with the telephone-receiver off the hook, in the same condition as it is when called by some other subscriber. Fig. 2 is a side elevation of the dial instrument. Fig. 3 is a detail of the stopping mechanism. Fig. 4 is a front view of transmitting instrument with both dials removed, showing arrangement of starting mechanism, machine now stopped and in connection with another station, receiver off the hook. Fig. 4^a shows the kind of stops used to limit the dials to one complete revolution. Figs. 5 and 6 are diagrams of dials and connections in two different positions. Fig. 7 shows a portion of the dial instrument as it appears after the dial has been revolved by hand and as it stands when ready to start, telephone-receiver on hook and plug in hole 1, preparatory to connect with station No. 1. Fig. 7^a represents the starting-handle. Fig. 8 shows the metallic circuits of two subscribers in connection on an eight-subscriber exchange. Fig. 9 shows the dial instrument connected on a general return-wire system. Figs. 10, 11, and 13 show the method of polarizing the sets of electromagnets. Fig. 12 is an elevation of the back part of the dial instrument. Fig. 14 shows the mainspring adjustment, and Fig. 15 the arrangement of the contact-arms and connecting-bars at the central station.

Referring to Figs. 1, 2, and 12, C and D rep-

resent the framework (in which all the shafts run and the other parts are supported) of the transmitting instrument. A is the dial, perforated around the larger part of its circumference with forty-nine holes, making with itself added a fifty-subscriber transmitter. This dial, provided with the handle *Hn*, is rigidly attached to the main shaft 51, which carries on its opposite end a spring *Sp*, Fig. 14. The shaft also, through the gears 55, 57, and 59 and the pinions 56, 58, and 60, is connected with the armature of a magneto-electric machine *Arm.* 72, 73, and 74 (shown also at bottom of drawing Fig. 2) are parts of a simple clutch arranged to allow the shafts 51 and 52 to be turned in one direction without turning the rest of the gearing.

Fig. 9 shows the connections of one subscriber's apparatus on an eight-subscriber exchange. As the action is the same as it would be on a fifty-subscriber exchange, and although a different system is preferred and is hereinafter described, to simplify the explanation of the dial instrument a general return system is here illustrated.

85 85 are the coils of a common polarized electromagnet, here represented without the permanent magnets. It is well known that this kind of electromagnet responds only to alternating currents, the armature being pivoted in the center. The dial instrument is connected, as shown, by the wire *Op* and general return-wire directly to the electro-

magnets. In Fig. 2, *p* and *q* are springs pressing against the two dials B and A, respectively, and *p''* is a spring connecting *p* to one end of the armature-conductor. The line-terminals are at the spring 63 on the other end of the armature and the spring *q* bearing against the front dial.

In Fig. 7, *Ins* 1 is a piece of insulating material set into the front dial and is bounded by the lines connected at the corners *a*, *b*, *c*, and *d*. *Ins* 2 is a similar piece set in the back dial B and is inclosed by the lines of which *e*, *f*, *g*, and *h* are the corners. The back dial B is mounted loosely on the shaft 51 and is normally held with its permanent pin *x* against the stop 61 by a small clock-spring. (Shown in Fig. 2 at 71.) *r* is an oblong stop fastened on dial B. As the dial stands normally at rest the circuit connections are as shown in Fig. 5 and is on open circuit because of the spring on the front dial being on the insulated section.

In operation supposing No 1 is wanted, a plug of suitable size is placed in hole 1 on the front dial and the entire dial turned around by the handle *Hn*, Fig. 2, in the direction of the arrow, Fig. 5. Suitable stops, as described hereinafter, prevent turning the dial too far. Upon releasing the handle the dial stands still on account of the magnets *mg* *mg*, Figs 2 and 4, holding the armature. The subscriber then presses down on the arm *Q'*, Fig. 7^a, which is fastened on the shaft *Q*

and extends to the back of the frame, terminating, as shown in Fig. 12, in the arm *am* and pawl *pw*. Suitable pins are placed, as shown, on each side of the arm to limit its motion, and another pin is placed just below the pawl to withdraw it from engagement with the wheel 59 when at rest. Upon pressing the handle *Q'* the arm is raised, and the pawl drops into engagement with the wheel 59, giving it sufficient impetus to start the mechanism running. In this fifty-subscriber dial the dial on the line of the holes was divided into fifty-eight parts. Forty-nine holes were drilled, and, as will afterward be described, a permanent pin was placed at the fiftieth division, making in all fifty points where the mechanism could be stopped. This leaves a space of eight divisions, which is taken up by the insulating material *Ins 1* and *Ins 2* on the two dials, equal to four divisions on each dial. As the dial was turned in the first place by hand the pin in hole 1 caught the stop *r*, Figs. 1, 2, and 7 and represented in Fig. 6 by the dotted lines, and carried the back dial around to the position shown in Figs. 6 and 7—that is, again on open circuit—but with the insulated section of the back dial carried to the left. The gearing of the front dial to the armature-shaft in this case is fifty-eight to one, so that each space between the holes represents one revolution of the armature. When the subscriber presses the handle *Q'* down, the mechanism starts and the armature has to make four revolutions before the spring *q*, Fig. 7, leaves the insulation on the front dial. Now for a space equaling one turn of the armature-shaft and armature both springs *p* and *q* are in electrical connection with the dials, a circuit is established through the dials and shaft 51, and consequently current will go over the line, and as two currents differing in direction are generated at each revolution of the armature electromagnet 85 85, Fig. 9, will have been operated forward once and backward once, causing the ratchet-wheel to turn far enough to place the arm attached on the next point or in connection with No. 1. When the plug was first inserted and the dial turned by hand, the spring in the case was wound up, spring 71 was also wound a little further, and the wheels beyond the clutch 72 73 were not turned, owing to the clutch not catching in that direction. The plug also struck the arm *H* on one side; but, as shown in Fig. 3, the arm is so arranged as to swing out of the way and allow the pin traveling in this direction to go past. From the preceding description it can readily be seen that the main-spring runs the mechanism on the backward motion of the dial and that the spring 71 brings the back dial to its normal position. When the spring *p* on the back dial reaches the first part of the insulation on said dial, the current is stopped and at the same time the plug in hole 1 strikes against the arm *H* on the opposite side from the first time. Arm

H in this direction is held from turning out of the path of the plug by the catch *G*, so that now the entire brake arrangement is operated, consisting of the arm *H*, catch *G*, and arm *F*, fastened rigidly to the shaft 67, to which also is attached the arm 65 and flat spring immediately in front. This latter constitutes the brake-shoe and is adjustable by the screws shown and is now thrown, by reason of the plug in hole 1 striking the upper end of arm *H*, forward against the wheel *E* on the armature-shaft. This stops the mechanism, first, because arm *F* is held back by the spring 75, Fig. 2, and, second, by reason of the brake stopping the wheel *E* and armature, the latter action being much the greater. The wheel *E* is preferably made of ordinary medium soft rubber, leather, or similar material. The mechanism now assumes the position shown in Fig. 1, with the exception that the plug in hole 1 occupies the position of *w*. (Shown in the drawings.) The brake is pressed against the wheel *E*, and the mechanism is now at rest. The switch-arm at the central station has been moved forward into connection with the next contact, representing subscriber No. 1. The calling subscriber now “rings up” over the connected telephone-lines and the general return-wire, the receiver is taken down, conversation is held, and when finished the subscribers hang up their receivers.

While conversation was going on and the receivers were off the hooks, the calling-subscriber's instrument assumed the position shown in Fig. 4. The arm *J* terminates in the ordinary telephone hook and switch connections, which are well known and are consequently not shown here. When the conversation has been terminated, the calling subscriber, as stated, hangs up his receiver, which by reason of its weight depresses the lever *J*, which has been held up by the spring *γ*, and accomplishes several results. Lever *J* is swung on a shaft *sf*, and *K* is another lever swung loosely on the same shaft and held with its left end forced down by the spring *K'*. *Kt* is a stop formed by bending a projection of *K* over the top of *J*, and *Kb* is another stop formed by bending another projection of *K* under *J*, leaving a space, as shown, for *J* to play between. When *J* is depressed by the receiver, *K* cannot move, because the mechanism is locked, wheel *P* is immovable, and the pawl *L*, fastened on *K*, is engaged in its teeth; but *J* can drop as far as the lower stop *Kb*. In doing so *M*, another arm swung on *J*, strikes with its lowest notched end the arm *k*, fastened to the collar *O*, which is in turn fastened to the shaft *N*. This last shaft is bent down under the curved end of catch *G*. When *k* is struck by *M*, the bent shaft *N* is turned, elevating its lower end and lifting the catch *G* off from the arm *H'*. This releases *H*, which now falls forward toward the right. At the same instant *F* is pulled back to the left by the spring 75, Fig. 2, and arm *H*, now free of the pin in the dial, also springs

back into an upright position through the action of spring *sn*, Fig. 3, this part of the mechanism now assuming the position shown in Fig. 7. The mechanism now being free, J continues to fall, carrying K and the pawl L. This turns the wheel P and restarts all the mechanism, the spring K' forcing K again ahead of J, giving a long sweep to the pawl L. The end *pa*, Fig. 4, of pawl L now strikes against the stop *st* and the pawl is withdrawn from the teeth of wheel P. The arm *j*, it should be stated, is for the purpose of striking the rod *m* on M and forcing the lower part of M off the arm *k* immediately after the arm H has been released. At the termination of M's movement its lower end strikes the piece 78 and withdraws M out of the way, the bent shaft is released, the bent portion or lower end falls back to place, G catches H' again, and H is ready to stop the mechanism again at the end of the operation. The instrument, having been started by the pawl L and ratchet-wheel P, now resumes its movement. As before stated, it stopped just as the first part of the insulation, *Ins* 2, came under the back spring *p*. The armature now has to turn four times again before current is sent, thus for the second time reaching the required speed for generating current effectively. When the insulated section is passed over, both springs are again in metallic contact with the dials, and as it is of no use to turn the back dial any farther and as it must be stopped in a position where a plug in hole 49 will engage with the stop *r* at some subsequent operation it is accordingly stopped by the pin *x* on the back of said dial striking the stop 61 on the front of frame C, Fig. 2. The front dial continues its movement until the balance of alternations necessary to turn the switch-arm at the central station entirely around over all the contacts to the place of starting has been sent. This occurs when the insulated section on the front dial gets around to its normal position, as shown in Fig. 1, the permanent pin on the back of the front dial (represented by the dotted circle *w*) stopping the instrument by causing the brake to act precisely as the plug in hole 1 did. When the back dial reaches its normal position, (shown also in Fig. 1,) a pin *t* on the back of the dial reaches a position shown by a similar dotted circle, (also lettered *t* in Fig. 4.) This forces the upper part of the curved lever 62 away from the frame and also forces the lower end nearer said frame. The lower end then strikes the pin *pn* on pawl L and throws the pawl out of engagement with the wheel P. This is done so that in answering a call from another subscriber and while the called-subscriber's dial instrument is at rest the lever J, controlling the telephone-switches, may be worked, which would be impossible if the pawl L continued its engagement, as the wheel is locked by reason of the brake being on.

In Fig. 1 the front dial is represented as broken away to show the construction behind

it. This dial, as before stated, is perforated with forty-nine holes. With forty-nine holes on a fifty-subscriber dial another pin is necessary to prevent a wrong number of alternations from being sent if the dial should accidentally be operated without inserting a plug in some one of the holes. To this end *s*, Fig. 1, is placed permanently on the back of the front dial one space from hole 1 and near enough the edge to hit the stop *r* and bring the insulation on the back dial into a proper position to prevent a wrong number of alternations being sent, but not near enough to operate the brake. The back dial's normal stop 61 swings between two pins *u* and *v* far enough to allow the back dial an entire revolution when the plug is in hole 49 on the front dial. The front dial is limited to one complete revolution by a similar arrangement on the front of the box containing the instrument and is shown in Fig. 4^a, *to* and *tp* being the pins between which the stop *ts* moves. In Fig. 2 shown mounted on the shaft 51 is a wheel 76, into which a catch 77 drops. This is clearly shown in Fig. 4^a. This arrangement is to prevent turning the dial only part of a revolution and starting it or to prevent stopping and setting the dial back after it has started and before it has resumed its normal position again. When the shaft 51 and wheel 76 are turned when winding the spring and otherwise preparing to operate, the catch 77 assumes the position shown by the dotted lines and acts as a pawl to prevent backward movement until an entire revolution has been completed, when, meeting the notch again, it assumes its normal position again only to be forced out and in the opposite direction when shaft 51 starts its backward motion and continues to act as a pawl in this direction until normal position of shaft and wheel 76 is again attained.

If only a simple mainspring is used to furnish the motive power, a difference in speed will result which is not desirable between the beginning and end of the operation of the instrument, the spring becoming comparatively weak toward the end. If the spring is tightened to remedy this weakness, the mechanism runs too fast at first. To remedy this, the gear-wheel 54, Fig. 2, has been provided. This wheel meshes in the pinion 70 on the main shaft 51 and is about four times larger than said pinion, so that the shaft 50 never makes more than one-quarter of a revolution. Upon starting when the mainspring is strong the arm W on the end of shaft 50 is in a vertical position and the heavy spiral spring R is pulling directly on a line with shaft 50, or, in other words, is on a dead-center. In consequence spring R does not help to run the dial instrument. As the instrument runs, however, arm W begins to travel to the left, first, upon a very short leverage, gradually increasing until the position shown in Fig. 12 is reached, the mainspring being at its

weakest and spring R now pulling with a good leverage to its best advantage. In this form of a transmitting instrument for an automatic telephone-exchange system each main and each compensating spring must be made adjustable, for the reason that when working over a long circuit the resistance is high and the speed is fast. When, on the contrary, the same instrument is operated over a short line, the resistance is much lower, the generator is to some extent short-circuited, and the speed becomes too slow. To provide for this adjustment, a box containing the mainspring is constructed in the manner shown in Fig. 14, in which a circular case is preferably cast on the back frame D and shown in section at S. Another circular case provided with a front T fits into the first and is held by the screws Sc in the first case, reaching through into a groove in the second case. These screws allow of the inside case turning around, but prevent its removal. One end of the spring Sp is fastened to the shaft 51, while the other end is fastened to the inside case. The front case is formed with teeth around its edge like a gear-wheel, and a pawl V prevents backward movement. Near one side of the gear-case is cast an elevation U, which is drilled out, leaving a hole in the center, into which a key may be inserted. This key back of the portion entering the hole is provided with a pinion that meshes in the teeth of T. By inserting this key and winding like a clock the desired tension may be attained, while to lower the tension all that is required is to hold the key steadily, raise the pawl, and let the case T back. Regulating-spring R is provided with a thumb-nut 69 (shown in the drawings) for adjustment purposes, which needs no explanation.

It will be seen from the foregoing description that after a subscriber has placed a plug in a desired hole, turned the dial, and pressed the handle thereafter all the operations are performed automatically, the plug may be left in any hole at any time, and hanging up the receiver resets the switchboard. It will also be seen from the description that no matter where a plug is placed or whether one is placed at all in the front dial fifty negative and fifty positive currents will be sent over the line at every complete revolution of the dial instrument when connected as shown in Fig. 9. The insulation on the back dial being slid around into any required position separates these currents into two groups and allows the armature always to attain the proper speed. The transmitter may be, as stated, used on a general return-wire system; but the best way known to me is to use it on the system now about to be described. This distinguishing feature of my invention uses only two wires from each subscriber and bridges in all operating-electromagnets during the time the lines are used for conversational purposes, and these magnets are bridged in such

a manner between the two sides of the metallic circuit that two comparatively high-resistance magnets are bridged in series with each other, thereby greatly increasing both the resistance and inductive retardation of the bridge-circuit. To accomplish this result, I arrange the circuits and operating-electromagnets as follows: Referring to Fig. 8, representing two stations, in which station No. 1 has connected himself with station No. 2, the parties are represented as in conversation, with both receivers off their hooks. The drawing refers to an exchange of eight subscribers, and each subscriber is provided at the central station with a traveling arm, which is adapted to make contact on the eight points, of which 97 and 98 are the first two, as desired. Similar points of all subscribers' switches are connected together; but for clearness only three are so represented. The circuit may be traced beginning with station No. 1's receiver through the secondary of the induction-coil SC, telephone-hook SW, line R_w, contact-point and spring 80, traveling arm 88, contact 98, over connecting-line to 98', traveling arm 88', line R_w', station No. 2's instruments, as at station No. 1, back over line O_w', through contacts 82' and 83' to common junction-wire CJ, through contacts 82 and 83, line O_w, back to station No. 1's receiver.

Both dial instruments at the subscribers' ends are bridged across the circuit; but as they are always on open circuit when at rest they have no effect on the lines at such time. It will be seen that as the switchboard now stands the regular switch-operating electromagnet 85 85 is bridged in series with the circuit-changing magnet 84 84 directly across the metallic circuit from conductor R_w to conductor O_w and also that magnets 85' 85' and 84' 84' are arranged in the same manner.

84 84 and 84' 84' are polarized electromagnets provided with armatures pivoted at their centers and carrying on their upper ends, as here represented, switches so arranged that when the armatures are tipped in the opposite direction to that shown in Fig. 8 the magnets operating the armatures will be thrown out of the bridge-circuit into the side of the metallic circuit R_w R_w'. The magnets operating the switchboard—85 85 and 85' 85'—are left bridged across the metallic circuit. When tipped in this last-named direction, it will be noticed that switches on the lower ends of armatures 99 and 99' have broken the other side of the metallic circuit O_w O_w' near 85 and 85', respectively. These, in fact, were the conditions when station No. 1 started to connect his circuit to that of No. 2. His own line was open just beyond where 85 85 is bridged in on the side O_w. When his receiver was on the hook, the other side of his circuit R_w was connected through the magnet-generator and bell 100 to the ground, so that when he operated his dial instrument the only path for the current was over the line R_w, contact-spring to 81, (main line now

open at 80,) through armature 99 to the junction between 84 84 and 85 85, through 85 85 to wire *Ow* back to dial instrument. After becoming connected to station No. 2 it will be seen that as both stations' receivers are on their hooks a grounded circuit extends from station No. 1 over line *Rw*, contact-spring and contact 81, armature 99, junction between magnets 84 84 and 85 85, through coils 84 84, traveling arm 88, contact 98, connecting-line to contact 98', traveling arm 88', electromagnet 84' 84', armature 99', contact 81', and spring to wire *Rw*, switch-hook, (now depressed,) magneto-bell 100' to ground again. Subscriber No. 1 now rings his magneto-bell over this circuit. This operates 84 84 and 84' 84' and also the other subscriber's bell. At the present time it makes no difference how 84 84 and 84' 84' are polarized, for if the first current is of the wrong polarity the next one will operate them. When the magnets operate, the armature tips over, and in doing so the magnets are thrown out of the grounded circuit and of course stay out, for the reason that they are no longer in circuit with the magneto-bell 100. The magnets 84 84 and 84' 84' are now in the bridge-circuits in series with 85 85 and 85' 85', respectively, precisely as represented in Fig. 8. One of the objects of having the circuit *Ow* open at 82 and 83 while operating the dial instrument is to prevent current going over the traveling arm and operating other subscribers' switch-magnets, which at every contact of the arm come in multiple with the operating subscriber one after another. Another object of the same arrangement will be explained hereinafter.

The electromagnets of all subscribers corresponding to 84 84 are polarized in an opposite polarity or are reversed in their connections in the bridge to the magnets corresponding to 85 85. In this system of operating the dial instrument is provided with an extra spring bearing against the back dial and shown by the dotted lines *p'*, Fig. 7. This is simply an extra contact-spring projecting ahead of the spring *p* just half the distance between two adjacent holes in the dial *A*. This is for the purpose of having an extra current of the same direction as the last one that placed the traveling arm 88 on contact 98. Supposing this last-named current to have been a positive one, then 85 85 and 85' 85' are not now influenced by positive currents. Therefore when the subscriber at station No. 1 hangs up his receiver and his dial starts the first current sent, owing to the advanced spring *p'*, will be a positive one, and as both sets of magnets are in parallel or multiple current will divide and go through each. Coils 85 85 and 85' 85', as stated, will not be operated, but coils 84 84 and 84' 84' being polarized in the opposite direction will be thrown back to their original position in the side *Rw* *Rw'*. Both subscribers' lines *Ow* and *Ow'* will be opened at 82 83 and 82' 83', so that

the next current from station No. 1's dial instrument can get to no other magnet but 85 85, which is operated by the currents now coming from the dial instrument and resets the switch 88 on contact 97 in the same manner as described on the general return-wire system.

It will be seen from the foregoing description that a subscriber's line is always open on the side *Ow* at 82 83 until the subscriber rings over his grounded side. After two subscribers become connected and take down their receivers the grounds at both ends are removed. If any one else connects their line to the lines of the parties connected, he cannot overhear their conversation, for the reason that his own line is open on one side and he cannot close it, because he has no ground to ring over and actuate his magnet corresponding to 84 84. It will thus be seen that the service is secret; but if *A* calls up *B*, *C*, and *D* one after another and tells them that he will leave his ground on until they all signal him by ringing then *B*, *C*, and *D* may all connect with *A*, when all the grounds are removed and the service still remains secret.

In Figs. 8 and 9 the central-station apparatus is shown mostly in diagram.

In Figs. 10, 11, 13, and 15 the preferable way of arranging the apparatus is shown. 92 is a shaft adapted to rotate between the trunnion-screws 93 93. 88^x is the ratchet-wheel through which motion is imparted. 90 90 are washers, the last ones near the ends preferably screwing on the shaft 92 to hold the wheel and other washers on. Between these washers are held arms 91 91. A single one is shown at the right, Fig. 15, and, as will be noticed, has a keyway punched on the inner circle. A corresponding one is sawed in the shaft, and a key holds all securely from turning. The small end of this arm is rounded, as shown, allowing it to easily slip into contact with the raised portions 95 of the conducting-bars 94, which are held in a suitable manner rigidly between the insulating-bars 96 96. The raised portions 95 of the conducting-bars are indispensable when a large number—for example, fifty—of arms 91 are used, for if they were not used two, three, or more bars would be in connection with one switch instrument at one time, if the arms were made short enough to be practical.

In Fig. 15 it will be seen that the lower shaft need revolve but one-eighth of a revolution to place one of its arms 91 on the last bar on which the arm of the other shaft normally stands, thereby putting them in connection, for the shaft 92 and arms attached are the equivalent of traveling arm 88, Fig. 8, while the dead bars 94 represent the connecting-wires from 97 98, &c., to 97' 98', &c.

The operating-electromagnets 85 85, Fig. 8, are polarized, a number in a set, by one set of permanent magnets, as shown in Figs. 10, 11, and 13, in which 88^A 88^A are the magnets

polarizing all the armatures of a set of electromagnets through the pole-pieces 88', and 89 89 are another set arranged with poles in an opposite direction from the first and magnetize all the electromagnet-cores of the set. The ratchet-wheels 88^x 88^x and shafts with arms are arranged with their accompanying electromagnets and connecting-bars on each end of the permanent magnets, as shown in Fig. 13. The electromagnets 84 84 84' 84', Fig. 8, are preferably polarized in the same manner.

In the foregoing description of my invention I use the word "ground" as a correlative term for any general return-conductor of a circuit, whether it be the earth, gas or water pipes in buildings or elsewhere, or by the use of a special wire for that purpose.

It is evident that I do not confine myself to the exact details shown, and the same may be modified without materially departing from the spirit and scope of my invention.

Having thus fully described my invention, what I claim as new, and desire to secure by Letters Patent, is—

1. In an automatic telephone or other electrical exchange system the combination of switch-operating electromagnets at a central station, metallic circuits radiating to substations, means for operating the switching-magnets at the central station consisting of a motor-driven magneto-electric generator, generating alternating currents, at each substation and controlled by a dial, and a movable plug for controlling the dial, substantially as shown and described.

2. In an automatic telephone or other electrical exchange system and at the central station thereof, polarized electromagnetic switching devices for operating the transfer instrument and connected to lines converging from substations to said central station, in combination with mechanical alternating-current generators of electricity at the substations, whereby the central-station transfer instrument is operated by alternating currents from said generators.

3. In an automatic telephone or other electrical exchange system, metallic circuits converging from substations to a central station, a central-station transfer instrument for effecting connections between the substations, electromagnets of relatively high resistance for operating the transfer instrument, said electromagnets being bridged in branch circuits uniting the two sides of each of the metallic circuits, telephone-receivers at the substations, all in combination with suitable means for operating the electromagnets whereby any substation telephone-receiver may be connected in multiple arc with its own operating-magnet, and the receiver and operating-magnet of another substation.

4. In an automatic telephone or other electrical exchange system metallic circuits extending from a series of substations to a cen-

tral station in which one side of each metallic circuit is normally connected through a signaling device to the ground at the substation end only; the other side of each metallic circuit being connected to a common junction at the central station but normally open-circuited at said central station, electromagnets for operating the central-station transfer instrument bridged across each metallic circuit, and electromagnets in the grounded side of each metallic circuit for closing the open circuit in the opposite side upon signaling over the grounded side when two or more metallic circuits are connected together.

5. In an automatic telephone or other electrical exchange system metallic circuits extending from a series of substations to a central station in which one side of each metallic circuit is normally connected through a signaling device to the ground at the substation end only; the other side of each metallic circuit being connected to a common junction at the central station but normally open-circuited at said central station; electromagnets for operating the central-station transfer instrument bridged across each metallic circuit, and electromagnets in the grounded side of each metallic circuit for closing the open circuit in the opposite side and contacts controlled by the last-named electromagnets for throwing said electromagnets out of the grounded circuit and into the bridge-circuit upon signaling over the grounded side when two or more metallic circuits are connected together.

6. In an automatic telephone or other electrical exchange system metallic circuits extending from a series of substations to a central station in which one side of each metallic circuit is normally connected to the ground at the substation end only; a signaling device normally connected in said grounded side at each substation; electromagnets in each grounded side at the central station for closing an open circuit in the other side of each metallic circuit and arranged with proper contacts for being thrown out of the grounded side and into series with the central-station switch-operating electromagnet of its appropriate circuit, these last-named electromagnets being permanently bridged across the said metallic circuit, upon operating the signaling device over the grounded circuit; all in combination with a source of electricity in the metallic circuit for throwing the first-named electromagnets out of the bridge-circuit back into the grounded side of the metallic circuit when required, substantially as shown and described.

7. In an automatic telephone or other electrical exchange system a transmitter for operating the central-station transfer instrument consisting of a magneto-electric generator of electricity, power-driven mechanism for revolving the generator-armature and means consisting of a movable plug and brake

operated thereby, for stopping the generator after a predetermined number of revolutions have been made.

8. In an automatic telephone or other electrical exchange system a transmitter for operating the central-station transfer instrument consisting of a backward and forward moving dial, a mechanical generator of electricity controlled by the dial and arranged to be run during the backward movement of the dial only, and means for stopping the dial at any one of several predetermined positions during its backward movement.

9. In an automatic telephone or other electrical exchange system a transmitter for operating the central-station transfer instrument consisting of a magneto-electric generator, rotary backward and forward moving circuit-closers for controlling the generator-currents, the insulating-sections on said circuit-closers being of sufficient width to break the generator-current and allow the armature to revolve several times on open circuit, all in combination with a source of power for running the generator.

10. In a transmitter for operating the central-station transfer instrument in an automatic telephone or other electrical exchange system the combination of a magneto-generator of alternating currents of electricity, backward and forward moving circuit-closers for controlling the generator-current, and means for stopping the circuit-closers at predetermined positions on their backward movement.

11. In an automatic telephone or other electrical exchange system a transmitter for operating the central-station transfer instrument consisting of the combination of backward and forward revolving dials, a magneto-generator of alternating currents of electricity, suitable gearing connecting the dials and generator, insulating-sections on said dials, springs adapted to convey the generator-current and bearing against said dials, means for retracting the dials and means for stopping the dials at predetermined positions during their backward movement.

12. In an automatic telephone or other electrical exchange system a transmitter for operating the central-station transfer instrument consisting of a magneto-generator of electric currents, spring-driven mechanism for running the generator, a dial for controlling the mechanism and for winding the spring manually, all in combination with suitable means for starting and stopping the mechanism after being wound manually as stated.

13. In an automatic telephone or other electrical exchange system a transmitter for operating the central-station transfer instrument consisting of backward and forward moving dials, a magneto-generator of electricity controlled by the dials, spring-driven mechanism for running the generator, all in combination with an auxiliary spring arranged to compensate for the weakening of the first

spring toward the last of its operation, substantially as shown and described.

14. In an automatic telephone or other electrical exchange system a transmitter for operating a central-station transfer instrument consisting of a mechanical generator of electricity, spring mechanism for running the same, a dial controlling the same, perforations in said dial, a plug for inserting in said perforations, pawl-and-ratchet arrangements for starting the mechanism, and a brake-lever for stopping the generator and operated by the plug striking the lever.

15. In an automatic telephone or other electrical exchange system a transmitter for operating the central-station transfer instrument consisting of a magneto-generator of electricity, spring mechanism for running the same, a perforated dial for controlling the mechanism, pawl-and-ratchet mechanism for starting the transmitter, a brake arrangement for stopping the same and a permanent pin inserted in the dial for actuating the brake at the end of the transmitter's operation.

16. In a transmitter for operating a central-station transfer instrument in an automatic telephone-exchange system, in combination with the generator-magnets, revolving armature and mechanism for driving the latter; a starting device consisting of a ratchet-wheel attached to a suitable part of the driving mechanism, a lever or arm actuated by hanging up the telephone-receiver, a pawl attached to same and adapted to engage with the ratchet-wheel, whereby in hanging up the receiver the attraction of the magnets is overcome and the armature and mechanism started.

17. In a transmitter for operating a central-station transfer instrument in an automatic telephone-exchange system a starting mechanism consisting of a lever for supporting the telephone-receiver, a pawl attached to the lever, a ratchet-wheel attached to the driving mechanism and whose teeth are arranged to be engaged by the pawl, a stop for withdrawing said pawl at the end of the lever's movement, a pin on said pawl, a lever actuated by the transmitter when coming to rest or normal position, and lying, when so actuated, in the path of the pawl-pin, thereby preventing the pawl engaging with the ratchet-teeth when the telephone-lever is operated.

18. In a backward and forward moving dial-transmitter for operating a central-station transfer instrument in an automatic telephone or other electrical exchange system, a magneto-electric generator, a brake-wheel on the generator-shaft, a brake adapted to come in contact with said brake-wheel and controlled by a backward and forward moving lever arrangement, whereby moving a pin in the dial-front against the lever in one direction does not affect the brake but operates said brake when the pin is moved against said lever in the opposite direction.

19. In an automatic telephone or other electrical exchange system and at the central station thereof, a group of switches for connecting different lines, electromagnets and
5 armatures for operating the same, a simple or compound permanent magnet magnetizing all the armatures, all in combination with

another simple or compound permanent magnet magnetizing all the cores of the electromagnets of the group.

WARD DECKER.

Witnesses:

J. S. GROSS,

E. A. HINCKLEY.