

J. C. SLATER.
TELEPHONE SYSTEM.

(Application filed May 23, 1898.)

(No Model.)

4 Sheets—Sheet 1.

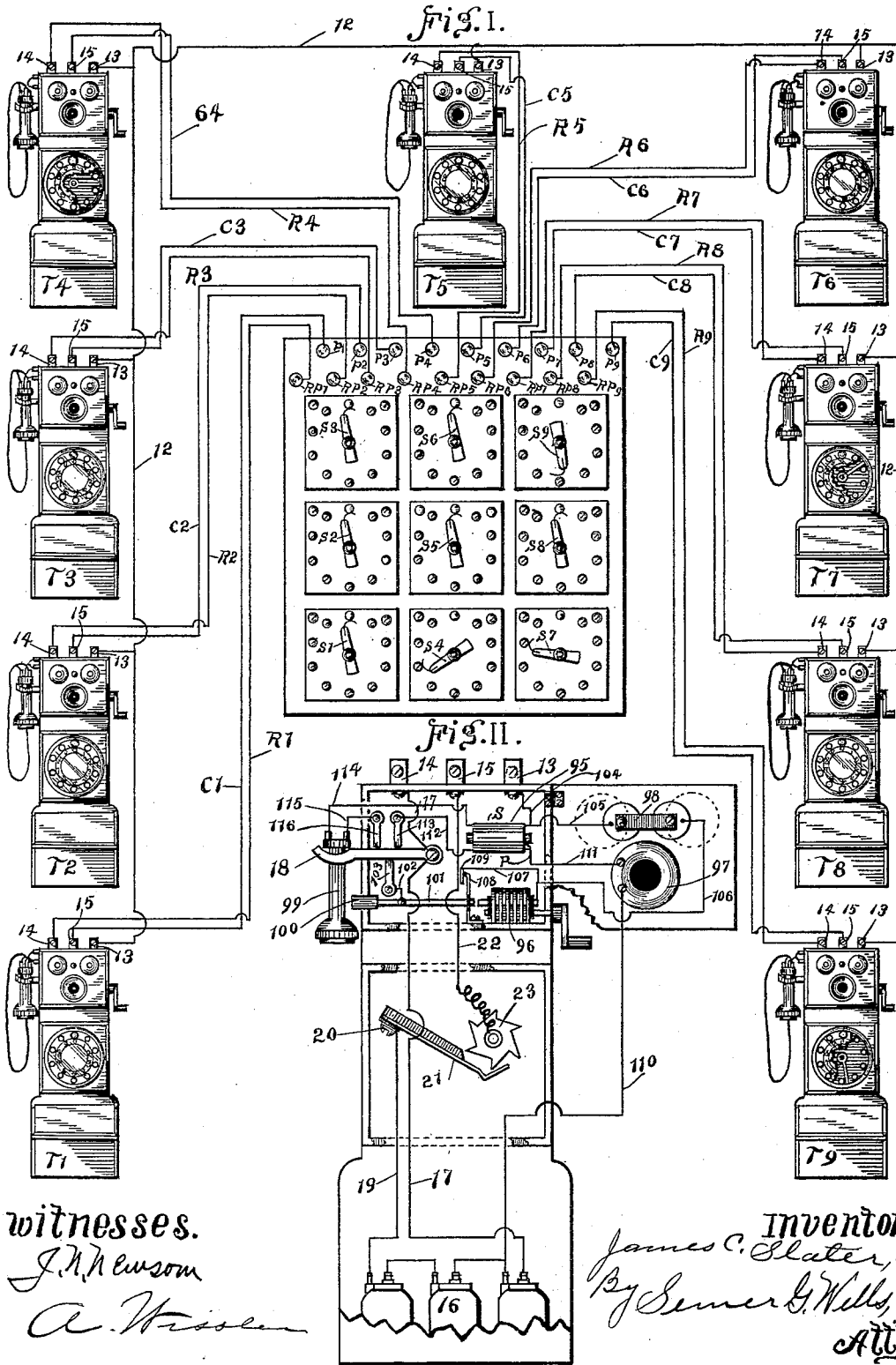

witnesses.
J. H. Newson
A. Wilson

Inventor:
James C. Slater,
By Samuel G. Wells,
Att'y.

J. C. SLATER.
TELEPHONE SYSTEM.

(Application filed May 23, 1893.)

(No Model.)

4 Sheets—Sheet 2.

FIG. III.

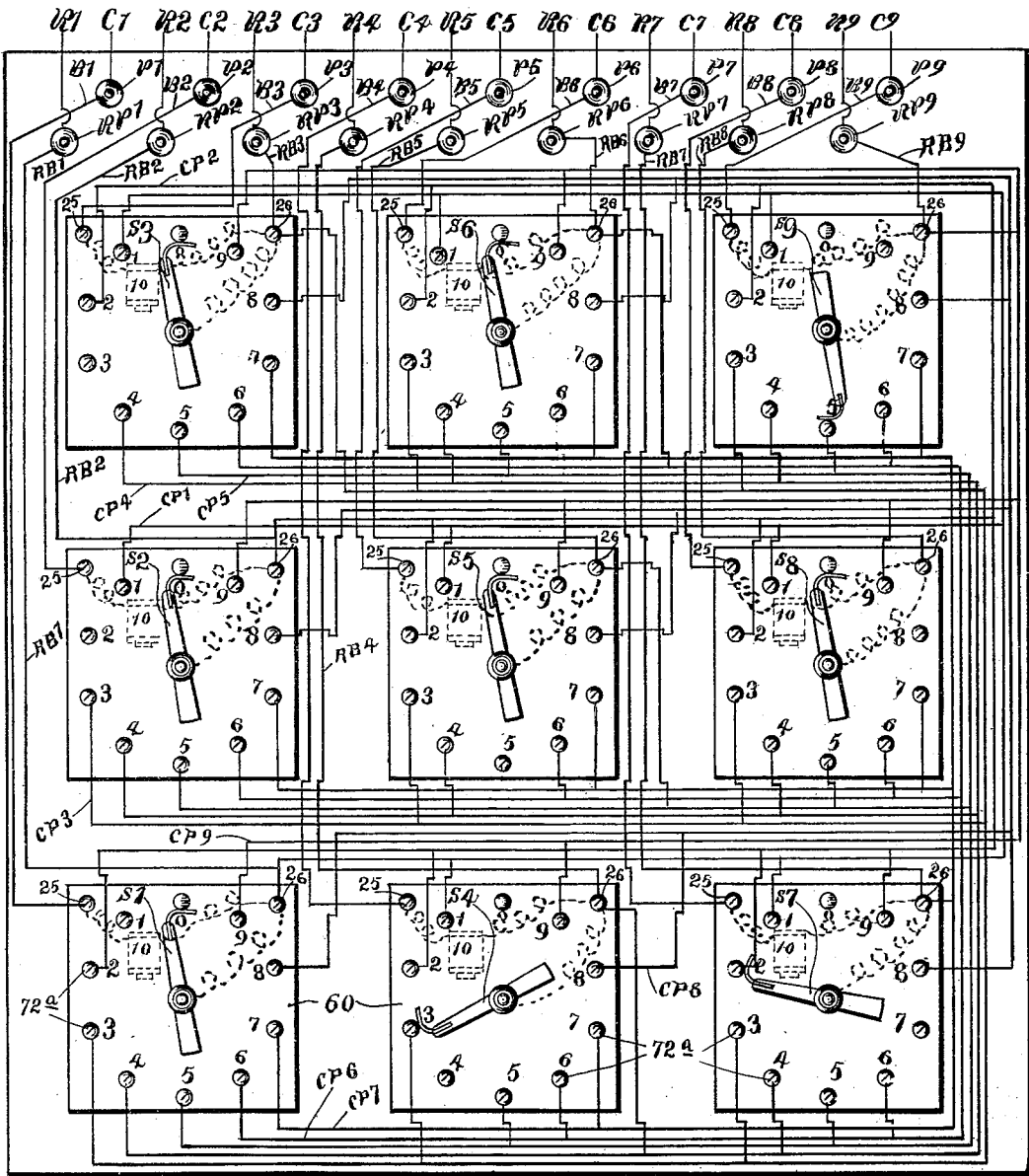

24

witnesses.

J. A. Newson

A. Wissen

INVENTOR

James C. Slater

By Demetrius G. Wells

Atty.

J. C. SLATER.
TELEPHONE SYSTEM.

(Application filed May 23, 1898.)

(No Model.)

4 Sheets—Sheet 3.

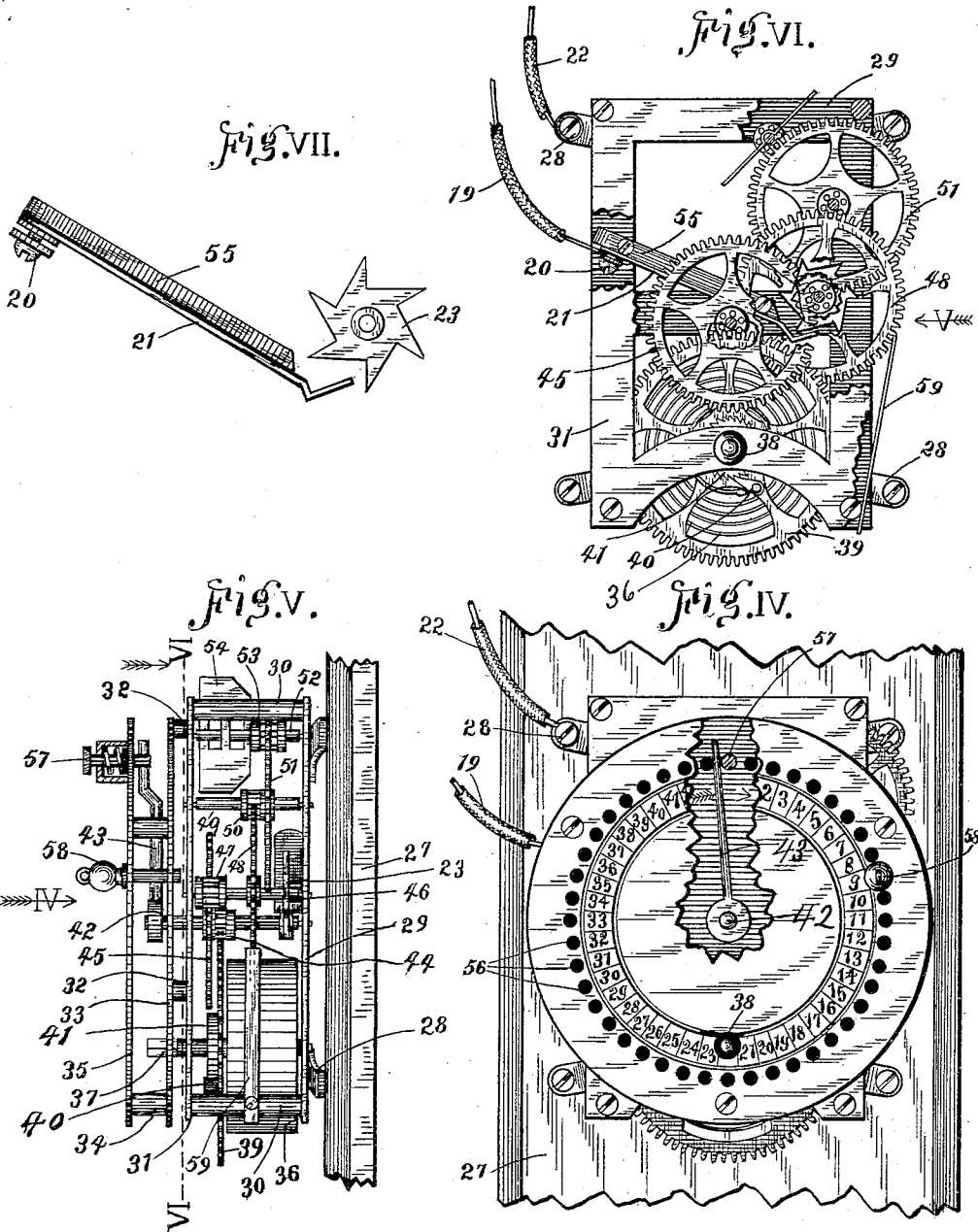

witnesses.
J. N. Newsom
A. Wasser

Inventor:
James C. Slater,
 By *Benjamin G. Wells,*
Atty.

No. 632,759.

Patented Sept. 12, 1899.

J. C. SLATER.
TELEPHONE SYSTEM.

(Application filed May 23, 1898.)

(No Model.)

4 Sheets—Sheet 4.

Fig. IX.

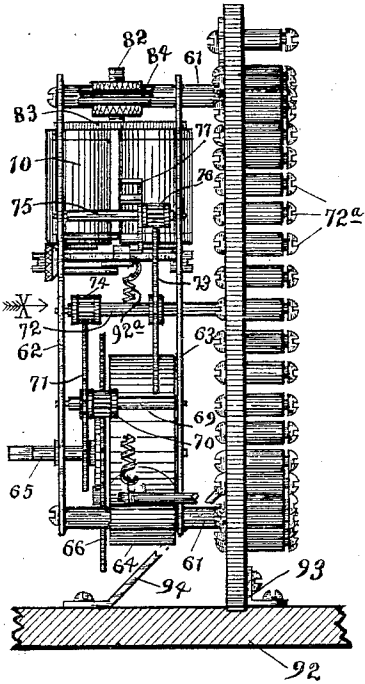

Fig. X.

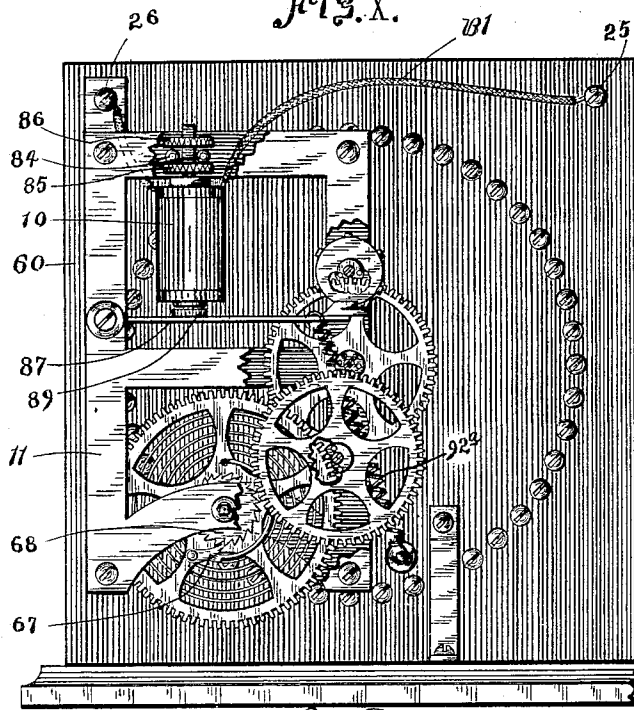

Fig. VII.

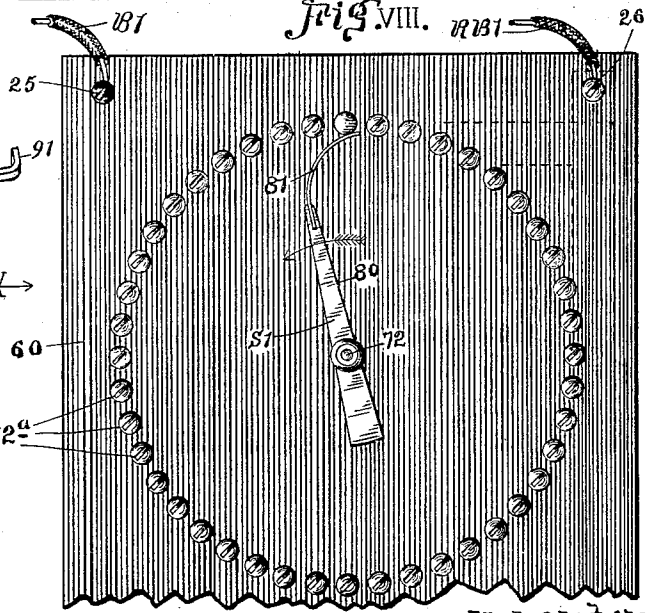

Fig. XI.

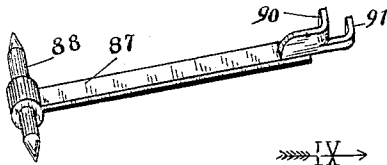
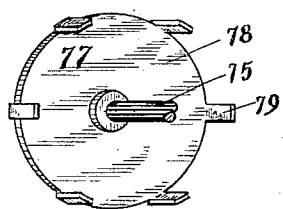

Fig. XII.



witnesses.
J. Newsom
A. Kissler

inventor:
James C. Slater
By Bennett & Wells
Attys.

UNITED STATES PATENT OFFICE.

JAMES C. SLATER, OF ST. LOUIS, MISSOURI.

TELEPHONE SYSTEM.

SPECIFICATION forming part of Letters Patent No. 632,759, dated September 12, 1899.

Application filed May 23, 1898. Serial No. 681,466. (No model.)

To all whom it may concern:

Be it known that I, JAMES C. SLATER, a citizen of the United States, residing in the city of St. Louis and State of Missouri, have invented an Improvement in Telephone Systems and the Like, of which the following is a specification.

My object is to construct a telephone system having an automatic exchange; and my invention consists of a switchboard having a switch for each telephone in the system; an electromagnet for each switch; mechanism for each switch, whereby the electromagnets operate the switches; a series of contact-points for each switch equal to the number of the other switches, each switch being numbered and having a correspondingly-numbered contact-point upon each of the other switches; telephones at outlying stations, one for each switch and correspondingly numbered; a circuit-breaker at each telephone; a battery at each telephone; a set of electric conductors running one from each telephone-receiver hook to the electromagnet of the corresponding switch, then back through the battery and circuit-breaker to the receiver-hook, said circuit-breakers being normally open, as required, to keep the energy of the batteries from the telephones and wires when not in use; a second conductor leading from each battery through the telephone-transmitter and through the primary of the induction-coils to the receiver-hooks; means for operating said circuit-breakers, and a third conductor connecting all the telephones together, said third conductor having branches passing through the secondaries of the induction-coils and through the receivers and serving as a return for the talking-circuits established by the operations of the switches; and my invention consists, further, of the details of construction herein shown, described, and claimed.

One of the great advantages of my system is due to the fact that it is impossible for a third party to hear a conversation going on between two other stations without deliberately cutting in, and thereby making his act known. The system is simple and inexpensive in construction and positive in its action, and there may be as many talking-cir-

cuits in operation at one time as there are pairs of telephones.

Another great advantage lies in the fact that the wires are normally deenergized by the open circuit-breakers, thus preserving the batteries, protecting the telephones and other mechanism, and preventing short-circuiting, &c. There being no source of electrical energy at the central station, the switchboard cannot become disarranged by short-circuiting during the time that the telephones are out of use.

Figure I is a diagram illustrating my improved telephone system and drawn for the purpose of showing the line-wires. Fig. II is a detail diagram of a telephone and circuit-breaker drawn for the purpose of showing the electrical connections. Fig. III is a diagram of the switchboard, showing the electrical connections. Figs. IV to VII show the details of the circuit-breaker and mechanism for operating the same. Fig. IV is a front elevation taken looking in the direction indicated by the arrow IV in Fig. V. Fig. V is a side elevation taken looking in the direction indicated by the arrow V in Fig. VI or in the same direction in Fig. IV. Fig. VI is a view taken looking in the direction indicated by the arrow on the line VI VI in Fig. V. Fig. VII is a view in elevation of the circuit-breaker with the operating mechanism omitted. Fig. VIII is a front elevation of a switch. Fig. IX is a side elevation taken looking in the direction indicated by the arrow IX in Fig. VIII, showing the electromagnets and the mechanism for operating the switch. Fig. X is a rear elevation taken looking in the direction indicated by the arrow X in Fig. IX. Fig. XI is a detail perspective of the escapement-lever, and Fig. XII is a perspective of the escapement-wheel.

Referring in detail to the drawings, I have shown a telephone system in which there are nine telephones, numbered T¹, T², T³, T⁴, T⁵, T⁶, T⁷, T⁸, and T⁹. The switchboard has nine switches, numbered S¹, S², S³, S⁴, S⁵, S⁶, S⁷, S⁸, and S⁹ to correspond to the numbering of the telephones. There is an electromagnet 10 for each switch, and clockworks 11, controlled by the electromagnets, operate the switches. Each switch has a series of contact-points,

numbered 1, 2, 3, 4, 5, 6, 7, 8, and 9 to correspond to the numbers of the telephones. The electric conductors, numbered C', C², C³, C⁴, C⁵, C⁶, C⁷, C⁸, and C⁹, run from the respective
 5 telephones to the respective binding-posts P', P², P³, P⁴, P⁵, P⁶, P⁷, P⁸, and P⁹, and the wires numbered R', R², R³, R⁴, R⁵, R⁶, R⁷, R⁸, and R⁹ run from the respective binding-posts RP', RP², RP³, RP⁴, RP⁵, RP⁶, RP⁷, RP⁸, and RP⁹
 10 to the respective telephones. The line-wire 12 has branches connecting it to each of the telephones. The wire 12 is connected to the right-hand binding-post 13 of each telephone. The conductors C', C², C³, C⁴, C⁵, C⁶, C⁷, C⁸,
 15 and C⁹ are connected to the binding-posts 15 of each telephone, and the wires R', R², R³, R⁴, R⁵, R⁶, R⁷, R⁸, and R⁹ are connected to the binding-posts 14 of each telephone. Each telephone is wired, as shown in detail in Fig.
 20 II. The three-cell batteries 16 are connected in a series and the wire 17 runs from the positive pole of the last cell to the pivot-screw of the receiver-hook 18 and then to the binding-post 14. The wire 19 runs from the negative
 25 pole of the first cell to the screw 20 of the circuit-breaker, thus making a connection with the contact-spring 21, and the wire 22 runs from the binding-post 15 to the toothed contact-wheel 23. The spring 21 is normally out
 30 of contact with the wheel 23.

The wiring of the switchboard is shown in detail in Fig. III. The binding-posts P' to P⁹ and RP' to RP⁹, inclusive, are attached to the board or wall 24. The board-wires B', B²,
 35 B³, B⁴, B⁵, B⁶, B⁷, B⁸, and B⁹ run from the respective binding-posts P' to P⁹, inclusive, to the binding-posts 25 of the respective switch mechanisms, then through the magnets 10, and then to the binding-posts 26. The return-board wires RB', RB², RB³, RB⁴, RB⁵, RB⁶,
 40 RB⁷, RB⁸, and RB⁹ run from the respective binding-posts RP' to RP⁹, respectively, to the respective binding-posts 26, thus completing the calling-circuits. The contact-point wires
 45 CP', CP², CP³, CP⁴, CP⁵, CP⁶, CP⁷, CP⁸, and CP⁹ make conductors from the respective switches through the binding-posts 26 to the correspondingly-numbered contact-points of each of the other switches. The wires RB' to
 50 RB⁹, respectively, connect with the wires CB' to CB⁹, respectively, at or near the binding-posts 26. There is a contact-point numbered 0 for each switch, and it is not in any circuit. The contact-point of each switch corresponding to its number is not in any circuit.
 55 These contact-points serve as indicators and to stop the switches at their regular intervals. The wire 12 does not or need not run to the switchboard.

The details of the mechanism for operating the circuit-breaker are shown in Figs. IV to VII. The front wall 27 of the telephone-box is used to support this mechanism. The feet
 60 28 are secured to the wall 27, and the back frame 29 is secured to the feet. Posts 30 extend forwardly from the frame 29, and the

front frame 31 is secured to the forward ends of these posts. Posts 32 extend forwardly from the front frame, and a disk 33 is attached to the forward ends of these posts. Posts 34
 70 extend forwardly from the disk 33, and the disk 35 is attached to the forward ends of these posts. A clock-spring and casing 36 is mounted upon the shaft 37 between the frames 29 and 31, said shaft extending through
 75 the disk 33 and having a square head to receive a clock-key, which is inserted through the keyhole 38 in the disk 35. A clock-gear 39 is loosely mounted upon the shaft 37 and carries a pawl 40, which engages the ratchet-wheel 41, fixed upon the shaft, as required, to allow the spring to be wound up without rotating the gear and communicating the power of the spring to the gear. A second shaft 42
 85 is mounted in the frames and extends forwardly through the disk 33, and a pointer 43 is fixed upon the forward end of said shaft. A pinion 44 and a gear 45 are fixed upon the shaft 42, said pinion meshing with the gear
 90 39. A third shaft 46 is mounted in the frames, and a pinion 47 and a gear 48 are fixed upon this shaft, said pinion meshing with the gear 45. The contact-wheel 23 is also fixed upon the shaft 46. A fourth shaft 49 is mounted
 95 in the frames, and a pinion 50 and a gear 51 are fixed upon this shaft, said pinion meshing with the gear 48. A fifth shaft 52 is mounted in the frames and carries a pinion 53, meshing with the gear 51. A fan 54 is fixed
 100 upon the shaft 52 to serve as a speed-regulator for the clockwork. A bar 55 of insulating material is secured to the back frame, with one of its ends near to the contact-wheel 23. The contact-spring 21 is secured to the bar
 105 55 by means of the screw 20, inserted into the opposite end of the bar from the contact-wheel. The free end of the spring is in position to yieldingly engage the teeth of the contact-wheel when the wheel rotates, and when the wheel is at rest the contact is broken.
 110 The wire 22 is attached to one of the feet 28, and the circuit passes through the framework to the contact-wheel. The wire 19 is connected to the spring 21 by the screw 20 and is insulated from the clockwork by the
 115 bar 55. The disks 33 and 35 have a series of perforations 56, arranged in a circle concentric to the shaft 42, said perforations being numbered 0 1 2 3, &c., to correspond to the numbers of the telephones, the switches, &c.,
 120 and the perforations of the rear disk being in alinement with the corresponding perforations of the front disk. There are more numbers upon the circuit-breaker than there are telephones, as required by the addition
 125 of more telephones to the system, until the system is full. The stop-pin 57 operates in the holes marked 0 in position to arrest the movement of the pointer 43. When it is desired to call a certain telephone, a removable
 130 pin 58 is inserted into the hole corresponding to the number of that telephone and the pin

57 is partially withdrawn until the pointer is released, and then the clockwork moves the pointer until it is arrested by the removable pin, and the movement of the clockwork makes and breaks the circuit by the operation of the contact-wheel 23 against the spring 21. A spring-pawl 59 is attached to one of the posts 30, and its free end engages the teeth of the gear 48, as required to prevent any backward motion of said gear.

The details of a switch-operating mechanism are shown in Figs. VIII to XII. Each switch is mounted upon a square flat block 60 of insulating material. I will assume that the switch shown is for telephone No. 1. The binding-posts numbered 0 1 2 3, &c., corresponding to the numbers of the telephones are arranged in a circle and project forwardly from the block 60. The posts 61 project backwardly from the block 60 and the front frame 62 and the rear frame 63 are supported by said posts in positions parallel with the block 60. The clock-spring 64 has its outer end attached to one of the posts 61 and its inner end attached to the shaft 65, which is mounted in the frames 62 and 63. The gear 66 is mounted loosely upon the shaft 65, and the pawl 67, carried by the gear, engages the ratchet-wheel 68, fixed upon the shaft, as required to communicate the power of the spring to the gear. A second shaft 69 is mounted parallel with the shaft 65, and the pinion 70 and gear 71 are fixed upon this shaft, said pinion meshing with the gear 66. A third shaft 72 is mounted in the frames and extends through the block and carries the switch S' on its forward end, said shaft being located at the center of the circle described by the binding-posts 72^a, forming the contact-points 0 1 2 3, &c. A gear 73 is fixed upon the shaft 72, and a pinion 74 is fixed upon the shaft and meshes with the gear 71. A fourth shaft 75 carries the pinion 76, meshing with the gear 73, and also carries the escapement-wheel 77, said escapement-wheel consisting of a disk 78 and arms 79, projecting from the periphery of said disk in lines parallel with the shaft.

The switch S' consists of a bar 80, fixed upon the shaft, and a contacting spring 81, projecting outwardly from the outer end of said bar and yieldingly engaging the contact-points 0 1 2 3, &c., and said contact-points are also binding-posts. A screw-threaded post 82 projects upwardly from the cross-bar 83 of the electromagnet 10 between the pair of pins 84, extending horizontally from one frame to the other. A nut 85 is placed upon the post 82 below the pins 84, and a similar nut 86 is placed upon the post above the pins, thus holding the magnet adjustably in position. The escapement-lever 87 is connected at one end to the shaft 88, which serves as a pivot, said lever occupying a horizontal position below the magnet and its free end operating in conjunction with the escapement-wheel. The

magnet-armature 89 is fixed upon the lever 87 in position to be operated by the magnet. The free end of the escapement-lever is split horizontally, thus forming the arms 90 and 91, said arms being turned backwardly, and the upper one of said arms being nearer to the pivot than the other, and said arms engaging the arms of the escapement-wheel. There are stops to limit the up-and-down movement of the armature-lever, and the spring 92^a withdraws the armature from the magnet. When the armature is elevated, one of the arms of the escapement-wheel passes under the upper one of the lever-arms and strikes the lower one of said lever-arms, and when the armature is again lowered this escapement-arm passes upwardly over the lever-arm and is released, thus producing a step-by-step motion, the clockwork operating the escapement-wheel and the magnet operating the escapement-lever. The switch is operated by the clockwork, and the magnet is operated by the circuit-breaker. The block 60 is secured in position upon the base 92 by means of the brackets 93 and 94. The shaft 65 has a square head to receive a clock-key to wind the spring.

Referring again to the wiring shown in Fig. 11, the induction-coil is indicated by 95, the primary being marked P and the secondary being marked S. The generator is indicated by 96, the transmitter by 97, the bell by 98, the receiver by 99, and the push-button of the generator by 100. Suppose that the receiver is on the hook, the desired telephones have been connected, and it is desired to ring the bell. The push-button 100 is pressed inwardly and the generator operated. The electrical impulses pass from the generator through the push-button rod 101, over the wire 102 and spring 103, through the receiver-hook 18, then over the wire 17 to the post 14, then over the wire R' and its connections to the bell of the called telephone, then over the wire 12 back to the post 13 of the calling-telephone, then to the bell of the calling-telephone over the wires 104 and 105, and then from the bell to the generator over the wire 106, thus completing the bell-circuit. The bell-circuit of the called telephone passes around its generator over the wire 107. The circuit over the wire 107 in the calling-telephone is broken by the operation of the push-button pressing the spring 108 away from the contact-point 109, to which the wire 107 is attached. After the bells have been rung and the push-button is released, the talking-circuit is ready for use. The transmitter is in a circuit running from one pole of the third battery-cell over the wire 110 to the transmitter, then over the wire 111 to and through the primary of the induction-coil, then over the wire 112 to the spring 113, to and through the receiver-hook, and then over the wire 17 back to the opposite pole of the battery-cell from which it started. The receiver is in a

circuit running from the post 13 over the wire 104 through the secondary of the induction-coil, then over the wire 114 through the receiver, then over the wire 115 to the spring 116, then through the hook to the wire 17, and then to the post 14.

The operation of my telephone system is as follows: A person goes to telephone No. 4 and desires to communicate with a person at telephone No. 3. He places the pin 58 in the perforation No. 3 in the disk 35 and then partially withdraws the pin 57 and releases the pointer 43. The clockwork moves the pointer until it strikes the pin 58, and while the pointer is thus moving the teeth of the wheel 23 engage the free end of the spring 21, thus making and breaking the circuit through the magnet 10 of the switch mechanism belonging to the telephone No. 4. The operation of the magnet 10 operates the escapement mechanism, thereby releasing the clockwork connected to the switch and moving the switch to the contact-point 3. The caller then presses the push-button 100 and operates his generator, thereby ringing the bell of the telephone with which he wishes to communicate, which in this instance is No. 3. The person hearing the bell goes to telephone No. 3, the push-button 100 is released, and communication is established between the two telephones. In this instance No. 4 is the calling-telephone, and No. 3 is the called telephone. In the first place the calling-circuit of telephone No. 4 runs from its batteries through the wire 17 to the post 14, then over the wire R^4 to the post RP^4 , then to the post 26 of switch mechanism No. 4, then through the magnet 10 to the post 25, then over the wire B^4 to the post P^4 , then over the wire C^4 to the post 15, then over the wire 22 to the contact-wheel 23, then to the spring 21, and over the wire 19 to the battery. As soon as the call is completed by the pointer 43 engaging the pin 58, the caller presses the push-button 100 and operates his generator, thus ringing the bell of the called telephone. The bell-circuit passes through the telephones, as heretofore described, and from the post 14 passes over the wire R^4 to the post RP^4 , then over the wire RP^4 to the post 26 of switch mechanism No. 4, then to the switch S^4 , then to contact-point 3, then over the wire CP^3 to the post 26 of switch mechanism No. 3, then over the wire RB^3 to the post RP^3 , then over the wire R^3 to the post 14 of telephone No. 3, then through the telephone, as heretofore described, to the post 13 of said telephone No. 3, then over the wire 12 to the post 13 of the calling-telephone No. 4, and then through the calling-telephone. As soon as the bell has been rung and answered talking communication is established over the same line-wires as the bell-circuit and through the telephones, as heretofore described. Thus it will be seen that the wires R^1 R^2 R^3 , &c., are in constant use when the telephones are in operation, whereas the wires

C^1 C^2 C^3 , &c., are only in use when the circuit-breaker is in operation, thereby operating the magnets and controlling the switches. All of the circuits are metallic.

Suppose that while telephone No. 4 is in communication with telephone No. 3 a person goes to telephone No. 7 and desires to communicate with telephone No. 2. The operation is exactly the same as that already described, and in the same manner communication may be established between telephone No. 9 and telephone No. 5 or between any other two telephones not already in use, there being no possibility of the circuits being crossed unless a person deliberately cuts his telephone into the circuit already in use, as would be the case if a person called either No. 4 or No. 3 while communication was going on between No. 4 and No. 3.

I claim—

1. A telephone system consisting of a switch-board having a switch for each telephone in the system; electrically-controlled mechanism for each switch for operating the switch, said mechanism being controlled from the telephone to which the switch belongs; telephones at outlying stations, one to a switch, said switches and said telephones being correspondingly numbered; an electric conductor running from the frame of each telephone to its switch-operating mechanism and back to the frame; a series of contact-points for each switch and in position to be engaged by the switch, there being one contact-point for each of the other switches in the system; a second set of conductors running one from each switch to each of the correspondingly-numbered contact-points of the other switches; a set of circuit-breakers, one at each telephone, for each of said first-mentioned conductors; means located at the telephones of supplying electrical energy to the circuits; mechanical means of operating and controlling the circuit-breakers; and a conductor connecting the telephones together and serving as a return-wire for talking-circuits established by the operation of the switches, substantially as specified.

2. A telephone system consisting of a switch-board having a switch for each telephone in the system; an electromagnet for each switch; mechanism for each switch whereby the electromagnets operate the switches; a series of contact-points for each switch equal to the number of the other switches, each switch being numbered and having a correspondingly-numbered contact-point upon each of the other switches; telephones at outlying stations, one to a switch and correspondingly numbered; a set of electric conductors running one from the frame of each telephone to the electromagnet of the switch, then back to the frame; a second set of conductors running one from each switch to each of the correspondingly-numbered contact-points of the other switches; a set of circuit-breakers one

at each telephone for said first-mentioned conductors; batteries at each telephone in the lines with the circuit-breakers and said circuit-breakers being normally open as required to keep the energy of the batteries from the telephones and wires when not in use; means of operating said circuit-breakers; and a conductor connecting all the telephones together, and serving as a return for the talking-circuits established by the operation of the switches.

3. A telephone system consisting of a switchboard having a switch for each telephone in the system; a set of electromagnets one for each switch; mechanism for each switch whereby the electromagnets operate the switches; a series of contact-points for each switch equal to the number of the other switches; telephones at outlying stations; a set of electric conductors running one from the frame of each telephone to the electromagnet of its switch and then back to the frame; a second set of conductors running one from each switch to each of the corresponding contact-points of the other switches; a set of normally open circuit-breakers one at each telephone for each of the first-mentioned conductors; a source of electrical energy for each telephone in the line of the circuit-breakers and a third conductor connecting all the telephones together and serving as a return-wire for the talking-circuits; said third conductor having branches passing through the secondaries of the induction-coils and through the receivers; substantially as specified.

4. In a telephone system, a series of switches mounted independently of each other; a series of contact-points for each switch; electrical connections between each switch and the corresponding contact-points of each of the other switches; electrically-controlled mechanism operated from the telephones for moving the switches, as required to move the switch of the calling-telephone until it engages the contact-point of the called telephone; wires making a conductor from the calling-telephone, through its switch to the switch of the called telephone, and then to the called telephone, all the other telephones being out of said line, said wires leading through the primaries of the induction-coils and to the receiver-hooks; and a wire connecting all the telephones and serving as a return-wire for said circuit; said last-mentioned wire having branches passing through the secondaries of the induction-coils and through the receivers; substantially as specified.

5. A telephone consisting of a switchboard having a switch for each telephone in the system; electrically-controlled mechanism for each switch for operating the switch; telephones at outlying stations; a set of electric conductors running one from the frame of each telephone to its switch-operating mechanism

and back to the frame; a series of contact-points for each switch and in position to be engaged by the switch; a second set of conductors running one from each switch to each of the corresponding contact-points of the other switches; a set of circuit-breakers, one at each telephone, for each of said first-mentioned conductors; means located at the telephones of supplying electrical energy to the circuits; mechanical means of operating and controlling the circuit-breakers; and a conductor connecting the telephones together and serving as a return-wire for the talking-circuits established by the operation of the switches, substantially as specified.

6. In a telephone system, a switchboard consisting of a series of switches; each of said switches comprising a shaft, a bar fixed upon the front end of the shaft and a contact-spring projecting outwardly from the outer end of said bar; a series of contact-points for each switch and in position to be engaged consecutively by the switch; a set of conductors connecting each switch with corresponding contact-points of the other switches; each of said conductors being electrically independent of each other and of all the contact-points except its own; electrically-controlled mechanism connected to and operating each of said switches independently of each other; telephones at outlying stations, one to a switch; a circuit-breaker at each telephone; a battery at each telephone; a metallic circuit connecting the battery, the circuit-breaker, the telephone-receiver hook and the mechanism for operating the corresponding switch together; a conductor leading from the battery through the telephone-transmitter, through the primary of the induction-coil and then to the receiver-hook; and a conductor connecting all the telephones together and having branches passing through the secondaries of the induction-coils, and through the receiver, substantially as specified.

7. In a telephone system, a switchboard consisting of a series of switches; electrically-controlled mechanism for operating the switches; telephones at outlying stations; a set of electric conductors running one from each telephone-receiver hook to the electrically-controlled switch-operating mechanism, then back to the receiver-hook; a second set of conductors leading through the telephone-transmitter and through the primary of the induction-coils to the receiver-hooks; and a third conductor having branches passing through the secondaries of the induction-coils and through the receivers, substantially as specified.

8. In a telephone system, switches at a central station; electrical mechanism for controlling each switch independently of the other; contact-points in position to be engaged by the switch; conductors connecting each switch with the corresponding contact-points of the other switches; telephones at

- outlying stations one to a switch; a circuit-breaker at each telephone; a battery at each telephone; a metallic circuit connecting the battery, the circuit-breaker, the telephone-receiver hook and the mechanism for operating the corresponding switch together; a conductor leading from the battery through the primary of the induction-coils and then to the receiver-hook; and a conductor connecting all the telephones together and having branches passing through the secondaries of the induction-coils, and through the receiver, substantially as specified.
9. In a telephone system, a switch; spring-actuated clockwork attached to the switch for operating the same, and an escapement mechanism for controlling the clockwork; said escapement mechanism consisting of an electromagnet mounted with its cores in a vertical position; an escapement-lever mounted in a horizontal position below said magnet; an armature attached to the intermediate portion of said lever; arms projecting laterally from the free end of said lever one above the other and one farther from the pivot than the other; an escapement-wheel driven by the clockwork; and arms projecting laterally from said wheel in position to be engaged alternately by the arms of the escapement-lever, as required to give a step-by-step movement to the switch when the escapement-lever is operated by the action of the magnet, substantially as specified.
10. In a telephone system, an automatic switchboard; telephones at outlying stations; a set of electric conductors running one from each telephone to the switchboard mechanism and back to the telephone; a second set of conductors running one through each telephone-transmitter and through the primary of the induction-coil; and a third conductor having branches passing through the secondaries of the induction-coils and through the receivers, substantially as specified.
11. A telephone system, consisting of a switchboard having a switch for each telephone in the system; an electromagnet for each switch; mechanism for each switch whereby the electromagnets operate the switches; a series of contact-points for each switch equal to the number of the other switches, each switch being numbered and having a correspondingly-numbered contact-point upon each of the other switches; telephones at outlying stations, one for each switch and correspondingly numbered; a circuit-breaker at each telephone; a battery at each telephone; a set of electric conductors running one from each telephone-receiver hook to the electromagnet of the corresponding switch, then back through the battery and circuit-breaker to the receiver-hook, said circuit-breakers being normally open as required to keep the energy of the batteries from the telephones and wires when not in use; means of operating said circuit-breakers, and a third conductor having branches passing through the secondaries of the induction-coil and through the receivers, and serving as a return for the talking-circuit established by the operations of the switches, substantially as specified.
12. A telephone system consisting of a switchboard having a switch for each telephone in the system; electrically-controlled mechanism for operating the switches; a series of contact-points for each of the switches, equal to the number of the other switches; telephones at outlying stations; a circuit-breaker at each telephone; a battery at each telephone; a set of electric conductors running one from each telephone-receiver hook to the switch-operating mechanism, then back through the battery and circuit-breaker to the receiver-hook; a second conductor leading from each battery through the telephone-transmitter, and through the primary of the induction-coil, and a third conductor having branches passing through the secondaries of the induction-coil, and through the receivers, and serving as a return for the talking-circuits established by the operation of the switches; substantially as above set forth, and for the purposes specified.
13. An automatic telephone system, consisting of a switch at the central station for each telephone in the system; and an electromagnet for each switch; mechanism for each switch whereby the electromagnets operate the switches; telephones at outlying stations, and an electric conductor running from each telephone to the electromagnet of its switch-controlling mechanism and then back to the telephone; a second conductor running from each switch to each of the corresponding contact-points of the other switches; as required to allow of the telephones being automatically connected in pairs; a normally open circuit-breaker at each telephone for each of the first-mentioned conductors; a source of electrical energy for each telephone, and a conductor connecting all the telephones together and serving as a return-wire for the talking-circuits, said conductor having branches passing through the secondary of the induction-coil; substantially as above set forth and for the purposes specified.
14. In a telephone system, an automatic switchboard; electromagnets for operating the switchboard; telephones at outlying stations; a set of electric conductors running one from each telephone through one of the electromagnets and back to the telephone; a make-and-break mechanism at each telephone for each of said conductors; a clockwork operating said make-and-break mechanism; a dial in front of said clockwork; stops operating through said dial; a pointer carried by said clockwork behind said dial and engaging said stops; said stops being withdrawable as required to release the pointer and allow the

clockwork to operate the make-and-break
mechanism, thus causing electrical impulses
to pass through said electromagnets and op-
erating the switchboard; a second set of con-
5 ductors running one through each telephone-
transmitter and through the primary of the
induction-coil; and a third conductor having

branches passing through the secondaries of
the induction-coils and through the receivers,
substantially as specified.

JAMES C. SLATER.

Witnesses:

A. WISSLER,
F. WISSLER.